

**SF2025B**

**259.861 MHz  
SAW Filter**

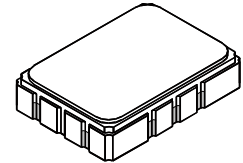

**SMP-03**

- **Designed for SDARS Receiver IF Application**
- **Low Insertion Loss**
- **5.0 X 7.0 mm Surface-Mount Case**
- **Differential Input and Output**
- **Complies with Directive 2002/95/EC (RoHS)**



**Absolute Maximum Ratings**

Rating	Value	Units
Maximum Incident Power in Passband	+10	dBm
Max. DC voltage between any 2 terminals	30	VDC
Storage Temperature Range	-40 to +105	°C
Suitable for lead-free soldering - Max Soldering Temperature	260°C for 30 s	

**Electrical Characteristics**

Characteristic	Sym	Notes	Min	Typ	Max	Units	
Nominal Center Frequency	$f_c$	1	259.861			MHz	
Passband	Minimum Insertion Loss	IL		13.3	15.5	dB	
		1.5 dB Passband	$BW_{1.5}$	13.8			MHz
	3 dB Passband	$BW_3$		14.5			
Amplitude Ripple from $f_c-6.354$ MHz to $f_c-4.2885$ MHz (-20 to 85°C)		1, 2			1	dB <sub>p-p</sub>	
Amplitude Ripple from $f_c-6.354$ MHz to $f_c-4.2885$ MHz (-40 to -20°C)					1.5		
Amplitude Ripple from $f_c-4.4965$ MHz to $f_c-2.431$ MHz					1		
Amplitude Ripple from $f_c-2.639$ MHz to $f_c+0.079$ MHz					1		
Amplitude Ripple from $f_c-0.079$ MHz to $f_c+2.639$ MHz					1		
Amplitude Ripple from $f_c+2.431$ MHz to $f_c+4.4965$ MHz					1		
Amplitude Ripple from $f_c+4.2885$ MHz to $f_c+6.354$ MHz (-40 to 60°C)					1		
Amplitude Ripple from $f_c+4.2885$ MHz to $f_c+6.354$ MHz (60 to 85°C)					1.15		
Group Delay Variation over $f_c-6.354$ MHz to $f_c-2.431$ MHz and from $f_c+2.431$ MHz to $f_c+6.354$ MHz	GDV1	1, 2, 3		40	60	ns <sub>p-p</sub>	
			Group Delay Variation over $f_c\pm 2.639$ MHz	GDV2	40		120
Rejection	$f_c-28$ to $f_c-12$ MHz and $f_c+12$ to $f_c+33$ MHz	1, 2, 3	36	43		dB	
			$f_c-12$ to $f_c-10.5$ MHz	30	40		
			$f_c+9$ to $f_c+12$ MHz	18	36		
Operating Temperature Range	$T_A$	1	-40		+85	°C	
Frequency Temperature Coefficient				-18		ppm/°C	
Differential Input and Output Impedance	L & C Match to 150 ohms						
Case Style		6	SMP-03 7 x 5 mm Nominal Footprint				
Lid Symbolization (YY=year, WW=week, S=shift) See note 4			RFM SF2025B YYWWS				

**Electrical Connections**

Connection	Terminals
Port 1 Hot	10
Port 1 Ground Return	1
Port 2 Hot	5
Port 2 Ground Return	6
Case Ground	All Others



**CAUTION: Electrostatic Sensitive Device. Observe precautions for handling.**

**Notes:**

1. Unless noted otherwise, all specifications apply over the operating temperature range with filter soldered to the specified demonstration board with impedance matching to 50 Ω and measured with 50 Ω network analyzer.
2. Unless noted otherwise, all frequency specifications are referenced to the nominal center frequency, fc.
3. Rejection is measured as attenuation below the minimum IL point in the passband. Rejection in final user application is dependent on PCB layout and external impedance matching design. See Application Note No. 42 for details.
4. "LRIP" or "L" after the part number indicates "low rate initial production" and "ENG" or "E" indicates "engineering prototypes."
5. The design, manufacturing process, and specifications of this filter are subject to change.
6. Tape and Reel Standard Per ANSI / EIA 481.
7. Either Port 1 or Port 2 may be used for either input or output in the design. However, impedances and impedance matching may vary between Port 1 and Port 2, so that the filter must always be installed in one direction per the circuit design.
8. US and international patents may apply.
9. Murata, stylized Murata logo, and Murata N.A., Inc. are registered trademarks of Murata Manufacturing Co., Ltd.

CH1 S11 1 UFS 1: 40 . 799 3. 3672 2. 0623 nH 259 . 861 000 MHz

hp

Cor

PRm

HLd

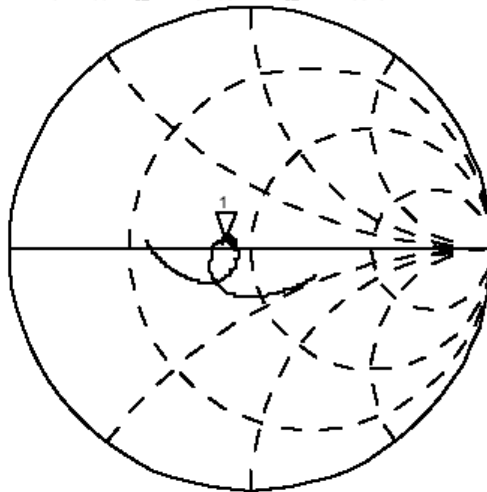

**CH2** S22 1 UFS 1: 39 . 922 7. 5566 4. 6282 nH 259 . 861 000 MHz

CH2 TARGET VALUE NOT FOUND

Cor

PRm

HLd

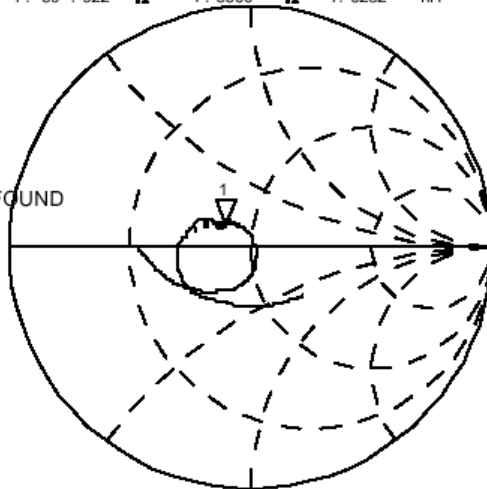

CH2 Markers

BW: 0.000000 MHz

cent: 0.000000 MHz

Q: 0.0000

1\_loss: 39.922 MHz

START 244 . 861 000 MHz

STOP 274 . 861 000 MHz

**SF2025B  
50 Ohm System**

## Matching Circuits

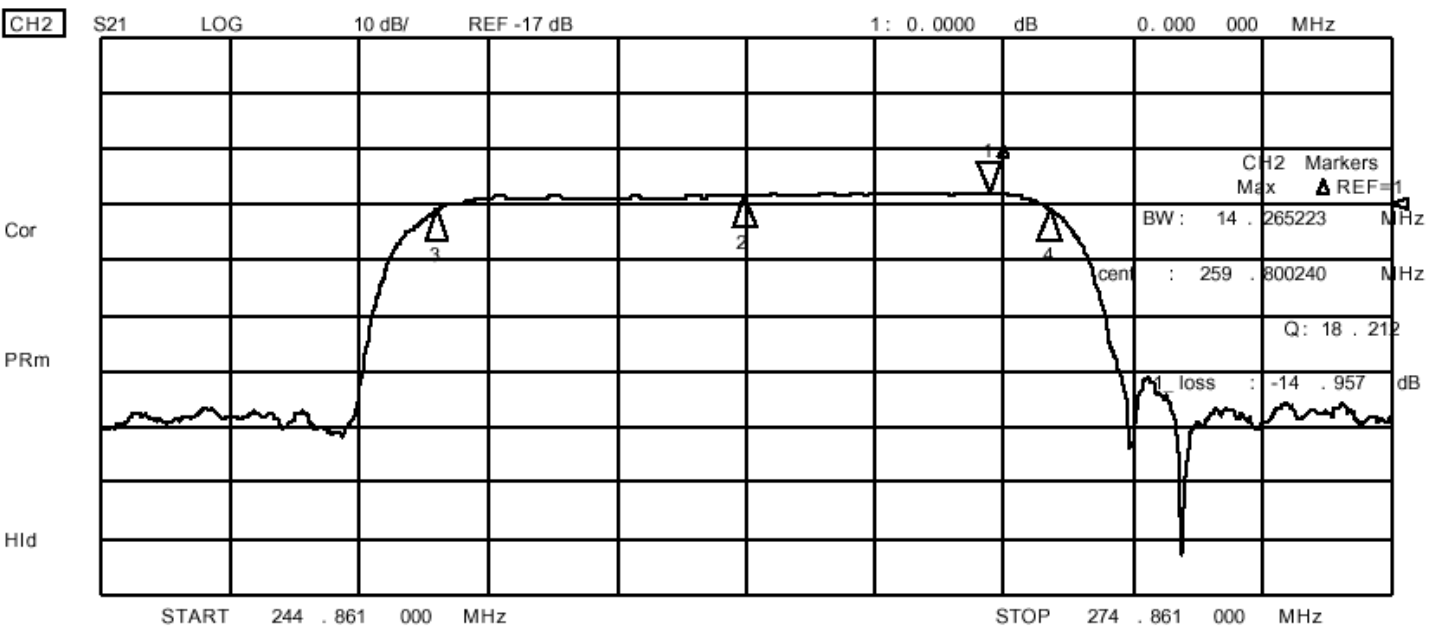
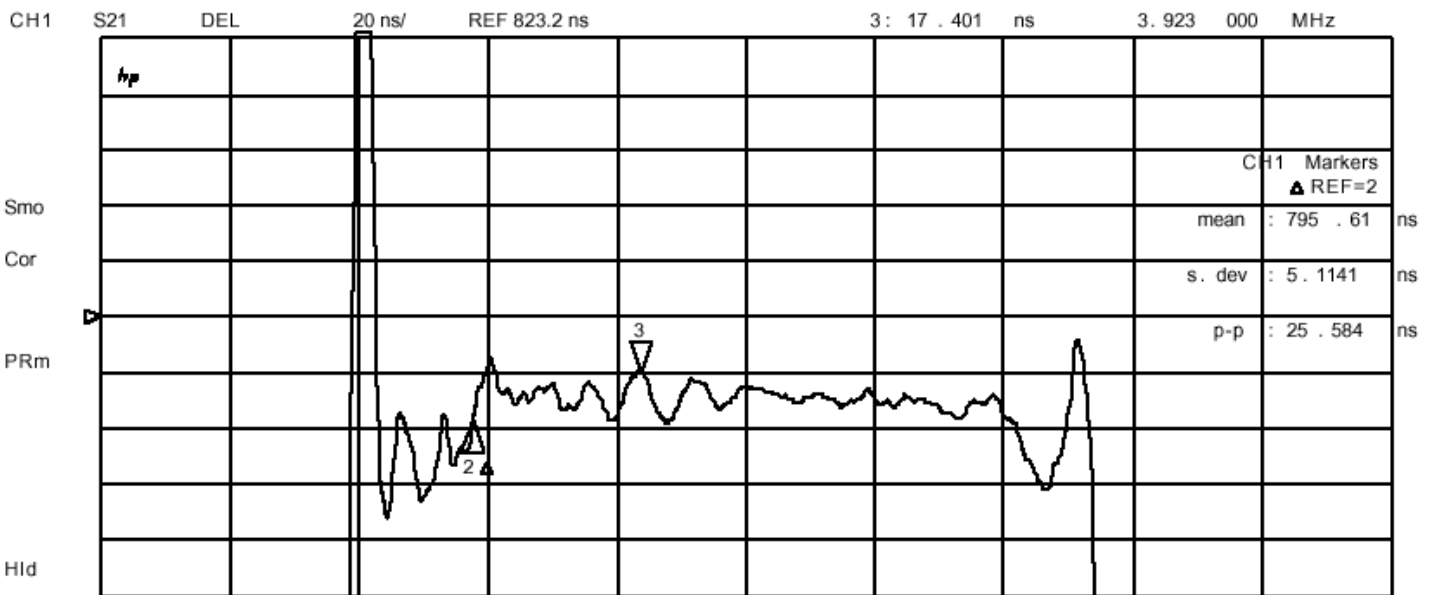
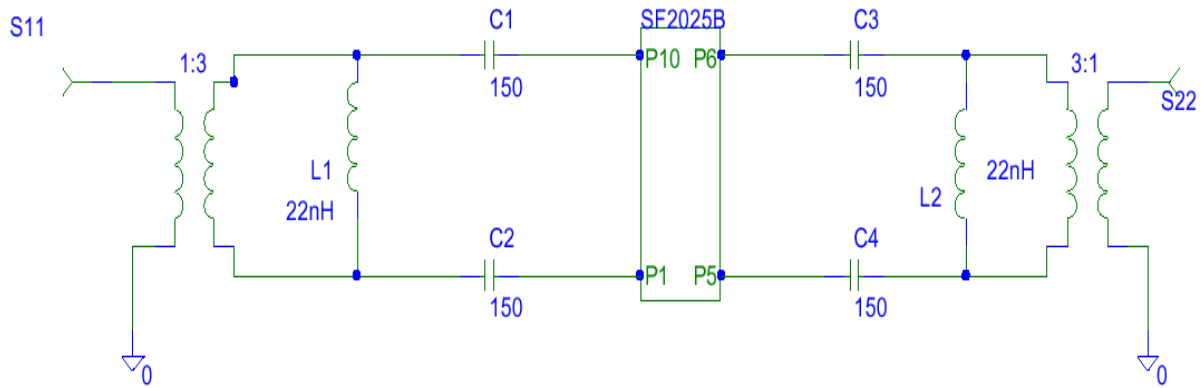

# Matching Circuits

better rejection tuning

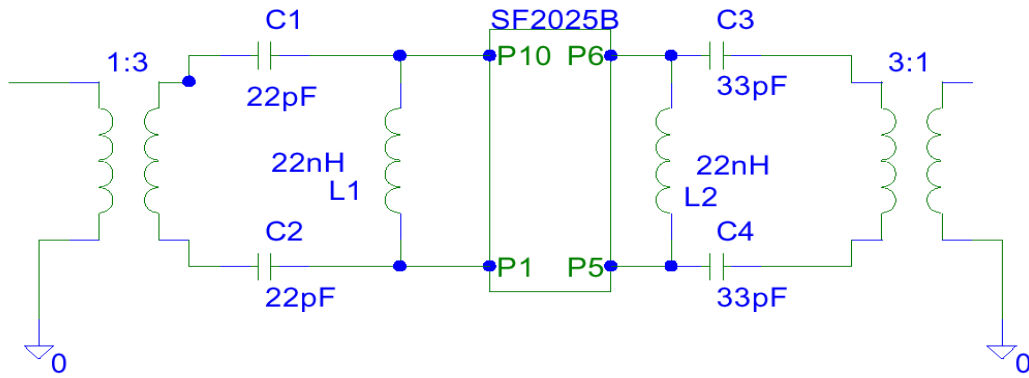

CH1 S11 1 UFS 1: 50 .018 11 .121 6.8112 nH 259 .861 000 MHz

z<sub>p</sub>

Cor

PRm

Hid

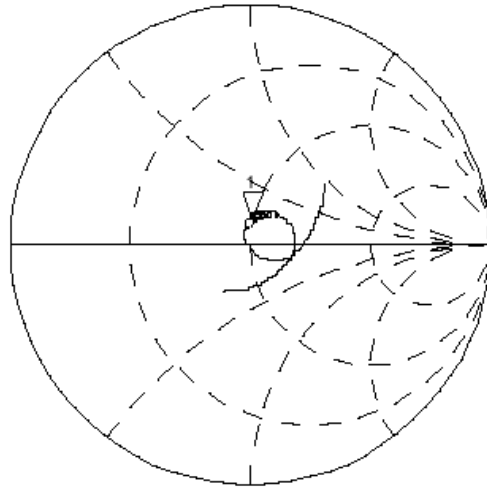

CH2 S22 1 UFS 1: 42 .555 11 .117 6.8089 nH 259 .861 000 MHz

CH2 TARGET VALUE NOT FOUND

Cor

PRm

Hid

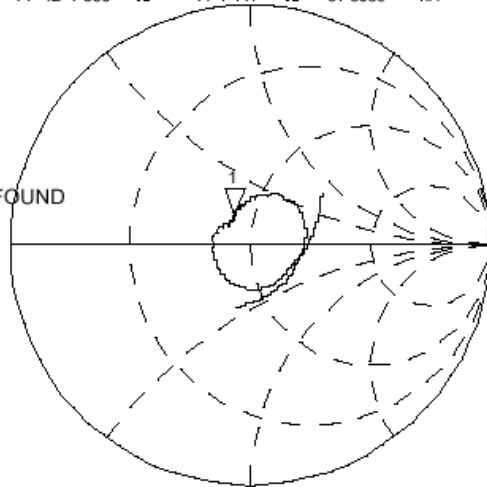

CH2 Markers

BW: 0.000000 MHz

cent : 0.000000 MHz

Q: 0.0000

1\_loss : 42.555 Ω

START 244 .861 000 MHz

STOP 274 .861 000 MHz

**SF2025B**  
50 Ohm System

22 Dec 2003 16:58:01

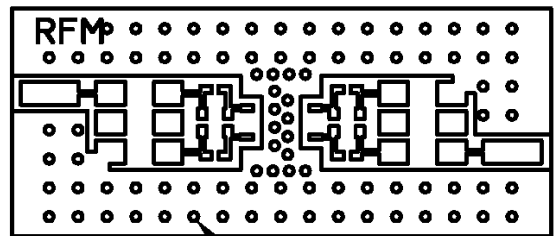
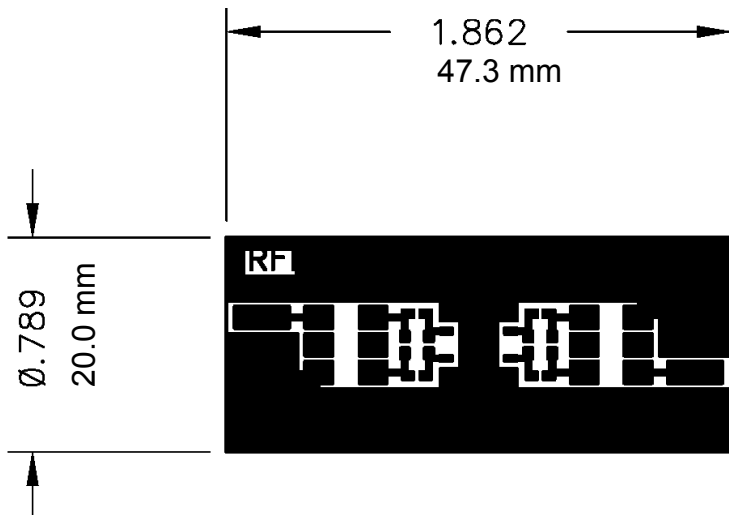
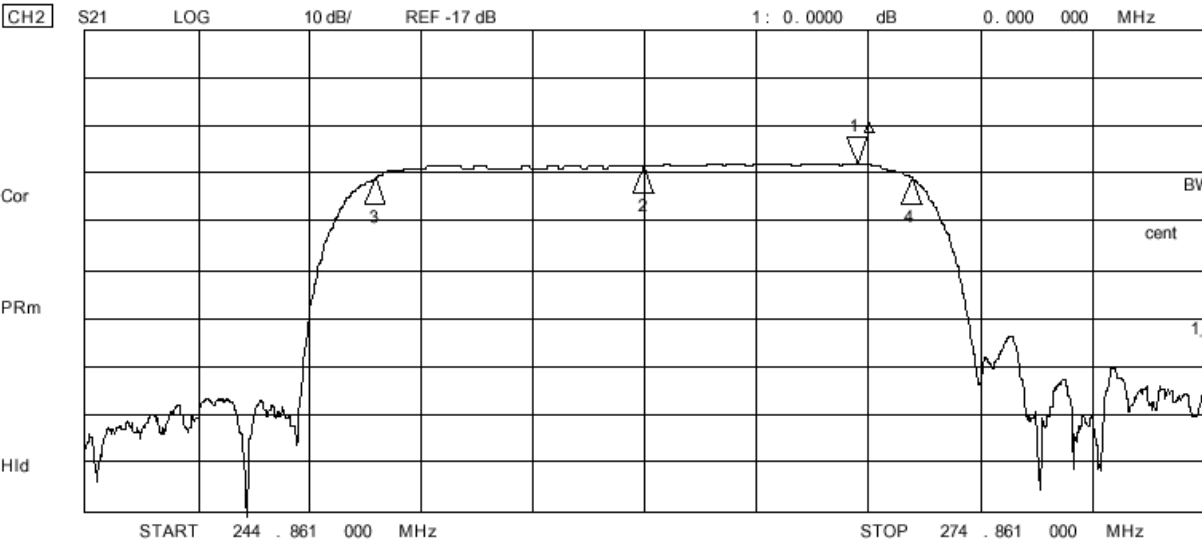
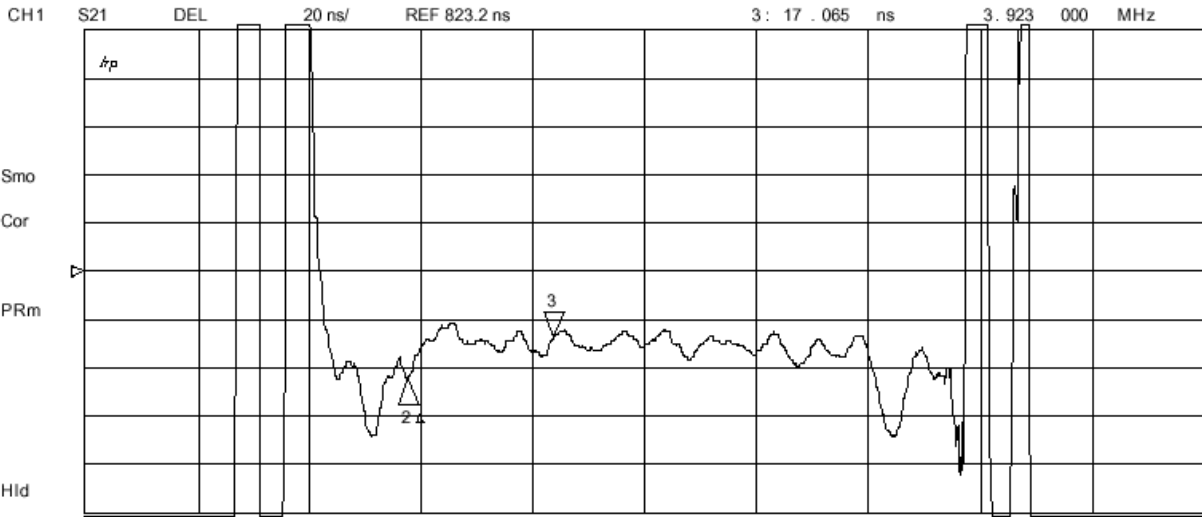

ALL HOLES PLATED THRU -  $\phi$ 1/32 DRILL

# SMP-03 Case

## 10-Terminal Ceramic Surface-Mount Case 7 x 5 mm Nominal Footprint

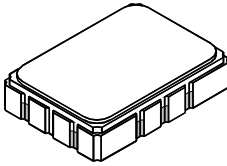

Recommended PCB Footprint

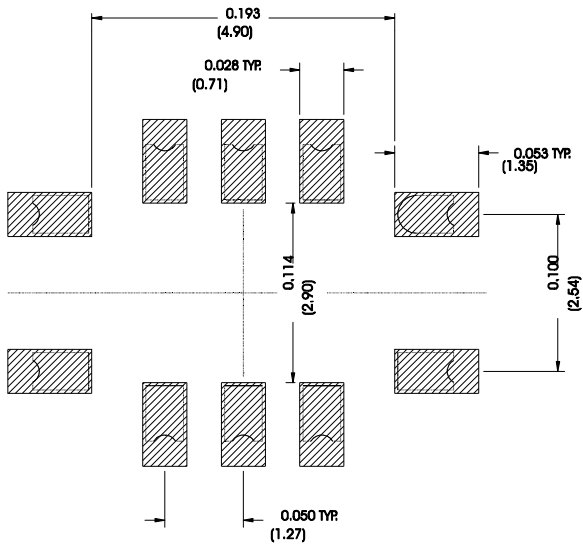

Case Dimensions						
Dimension	mm			Inches		
	Min	Nom	Max	Min	Nom	Max
A	6.80	7.00	7.20	0.268	0.276	0.283
B	4.80	5.00	5.20	0.189	0.197	0.205
C		1.65	2.00		0.065	0.079
D	.47	0.60	.73	0.019	0.024	0.029
E	2.41	2.54	2.67	0.095	0.100	0.105
H	0.87	1.0	1.13	0.034	0.039	0.044
J	4.87	5.00	5.13	0.192	0.197	0.202
K	2.87	3.00	3.13	0.113	0.118	0.123
P	1.14	1.27	1.40	0.045	0.050	0.055

Materials	
Solder Pad Termination	Au plating 30 - 60 μmches (76.2-152 μm) over 80-200 μmches (203-508 μm) Ni.
Lid	Fe-Ni-Co Alloy Electroless Nickel Plate (8-11% Phosphorus) 100-200 μmches Thick
Body	Al <sub>2</sub> O <sub>3</sub> Ceramic
Pb Free	

Electrical Connections		
Connection		Terminals
Port 1	Input or Return	10
	Return or Input	1
Port 2	Output or Return	5
	Return or Output	6
Ground		All others
Single Ended Operation		Return is ground
Differential Operation		Return is hot

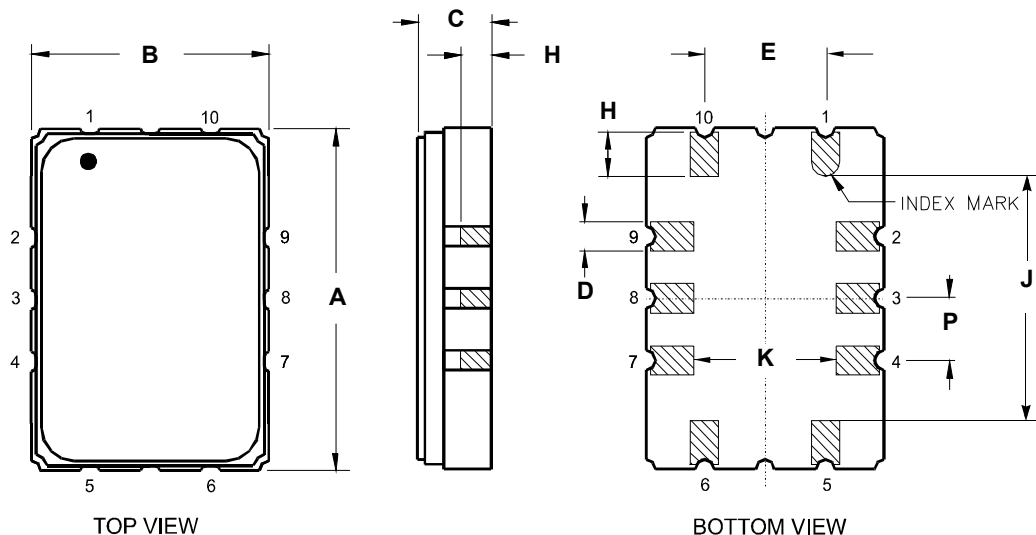

## Tape and Reel Specifications

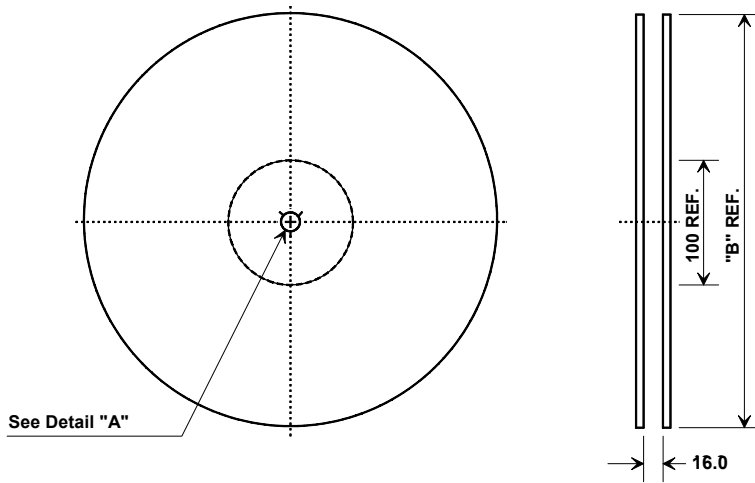

"B"		Quantity Per Reel
Inches	millimeters	
7	178	500
13	330	2000

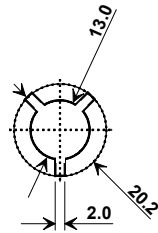

### COMPONENT ORIENTATION and DIMENSIONS

Carrier Tape Dimensions	
<b>Ao</b>	5.5 mm
<b>Bo</b>	7.5 mm
<b>Ko</b>	2.0 mm
<b>Pitch</b>	8.0 mm
<b>W</b>	16.0 mm

