



# BCP060T2

## HIGH EFFICIENCY pHEMT POWER FET CHIP (.25μm x 600μm)

The BeRex BCP060T2 is a GaAs Power pHEMT with a nominal 0.25 micron gate length and 600 micron gate width making it ideally suited for applications requiring high-gain and medium power in the 1000 MHz to 26.5 GHz frequency range. The product may be used in either wideband (6-18 GHz) or narrow-band applications. The BCP060T2 is produced using state of the art metallization with Si<sub>3</sub>N<sub>4</sub> passivation and is screened to assure reliability.

### PRODUCT FEATURES

- 29 dBm Typical Output Power
- 12 dB Typical Power Gain @ 12 GHz
- 0.25 X 600 Micron Recessed Gate
- 2 Gate Pads / 2 Drain Pads

### APPLICATIONS

- Commercial
- Military / Hi-Rel.
- Test & Measurement

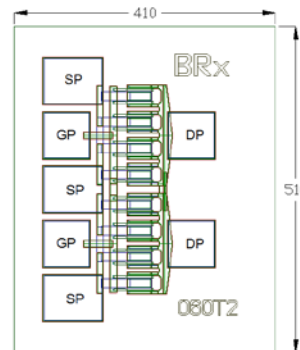

Chip dimensions : 410 X 510 microns  
 Gate pad(GP) : 75 X 75 microns  
 Drain pad(DP) : 75 X 75 microns  
 Source pad(SP) : 95 X 75 microns  
 Chip thickness : 100 microns

### DC CHARACTERISTICS T<sub>a</sub> = 25° C

SYMBOL	PARAMETER/TEST CONDITIONS	MIN.	TYPICAL	MAX.	UNIT
I <sub>dss</sub>	Saturated Drain Current (V <sub>gs</sub> = 0V, V <sub>ds</sub> = 2V)	120	180	240	mA
G <sub>m</sub>	Transconductance (V <sub>ds</sub> = 3V, V <sub>gs</sub> = 50% I <sub>dss</sub> )		240		mS
V <sub>p</sub>	Pinch-off Voltage (I <sub>ds</sub> = 0.6 mA, V <sub>ds</sub> = 2V)	- 2.5	-1.1	- 0.5	V
BV <sub>gd</sub>	Drain Breakdown Voltage (I <sub>g</sub> = 0.6 mA, source open)		-16	-12	V
BV <sub>gs</sub>	Source Breakdown Voltage (I <sub>g</sub> = 0.6 mA, drain open)		-14		V
R <sub>th</sub>	Thermal Resistance (Au-Sn Eutectic Attach)		65		°C/W

### ELECTRICAL CHARACTERISTIC (TUNED FOR POWER) T<sub>a</sub> = 25° C

SYMBOL	PARAMETER/TEST CONDITIONS	TEST FREQ.	MIN.	TYPICAL	MAX.	UNIT
P <sub>1dB</sub>	Output Power @ P <sub>1dB</sub> (V <sub>ds</sub> = 8V, I <sub>ds</sub> = 50% I <sub>dss</sub> )	12 GHz 18 GHz	27.5 27.5	29.0 29.0		dBm
G <sub>1dB</sub>	Gain @ P <sub>1dB</sub> (V <sub>ds</sub> = 8V, I <sub>ds</sub> = 50% I <sub>dss</sub> )	12 GHz 18 GHz	11.0 8.0	12.0 9.0		dB
PAE	PAE @ P <sub>1dB</sub> (V <sub>ds</sub> = 8V, I <sub>ds</sub> = 50% I <sub>dss</sub> )	12 GHz 18 GHz		65 60		%

**ELECTRICAL CHARACTERISTIC (TUNED FOR GAIN)  $T_a = 25^\circ\text{C}$**

SYMBOL	PARAMETER/TEST CONDITIONS	TEST FREQ.	MIN.	TYPICAL	MAX.	UNIT
$P_{1dB}$	Output Power @ $P_{1dB}$ ( $V_{ds} = 8\text{V}$ , $I_{ds} = 50\% I_{dss}$ )	12 GHz 18 GHz	25.5 26.0	27.0 28.0		dBm
$G_{1dB}$	Gain @ $P_{1dB}$ ( $V_{ds} = 8\text{V}$ , $I_{ds} = 50\% I_{dss}$ )	12 GHz 18 GHz	12.5 9.5	13.5 10.5		dB
PAE	PAE @ $P_{1dB}$ ( $V_{ds} = 8\text{V}$ , $I_{ds} = 50\% I_{dss}$ )	12 GHz 18 GHz		60 60		%

**MAXIMUM RATING ( $T_a = 25^\circ\text{C}$ )**

SYMBOLS	PARAMETERS	ABSOLUTE	CONTINUOUS
$V_{ds}$	Drain-Source Voltage	12 V	8 V
$V_{gs}$	Gate-Source Voltage	-8 V	-3 V
$I_{ds}$	Drain Current	$I_{dss}$	$I_{dss}$
$I_{gsf}$	Forward Gate Current	30 mA	5 mA
$P_{in}$	Input Power	24 dBm	@3dB Compression
$T_{ch}$	Channel Temperature	175° C	150° C
$T_{stg}$	Storage Temperature	-60° C - 150° C	-60° C - 150° C
$P_t$	Total Power Dissipation	2.1 W	1.7 W

Exceeding any of the above Maximum Ratings will result in reduced MTTF and may cause permanent damage to the device.

**$P_{IN\_P_{OUT}}$ /Gain, PAE (12 GHz)**

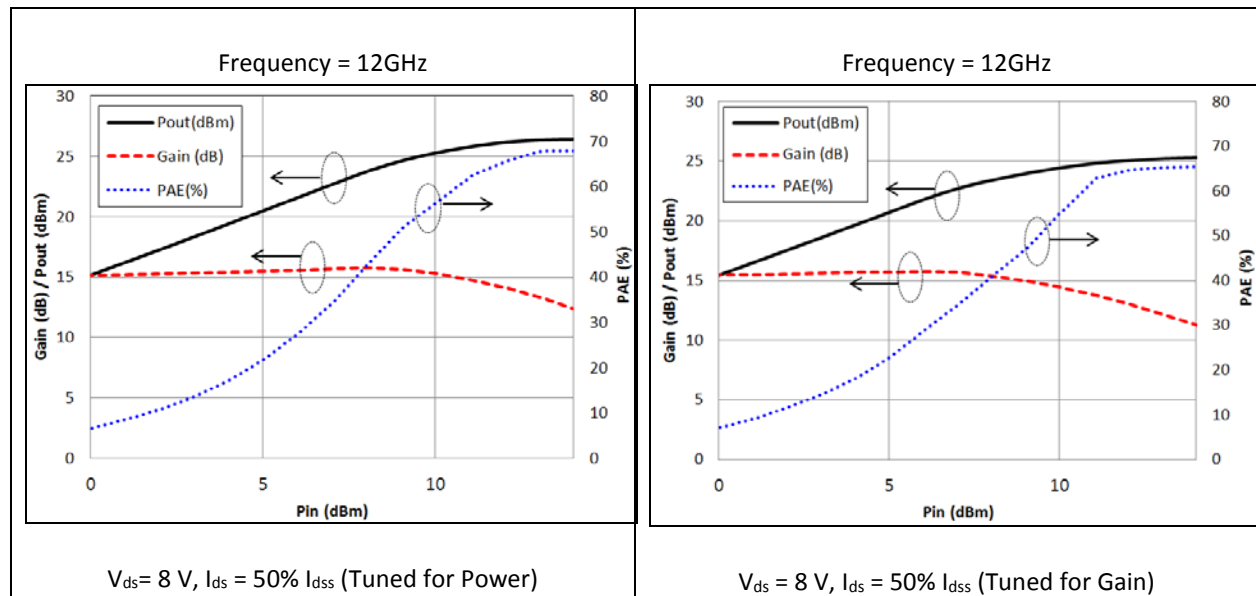

P<sub>IN</sub>\_P<sub>OUT</sub>/Gain, PAE (18 GHz)

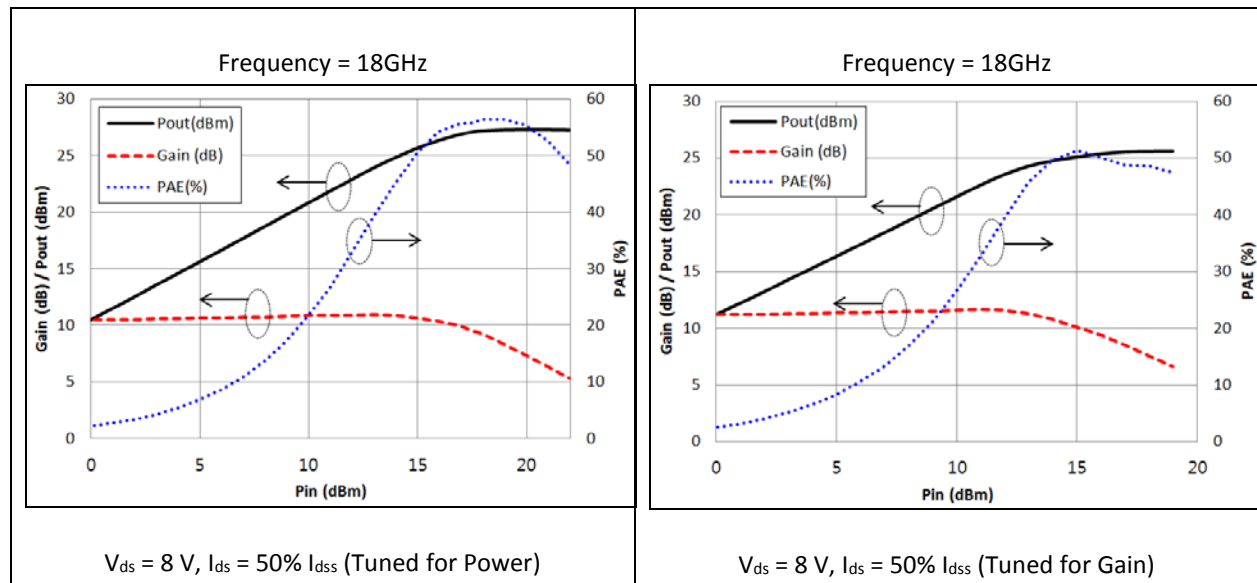

S-PARAMETER (V<sub>ds</sub> = 8V, I<sub>ds</sub> = 50% I<sub>dss</sub>)

FREQ. [GHZ]	S11 [MAG]	S11 [ANG.]	S21 [MAG]	S21 [ANG.]	S12 [MAG]	S12 [ANG.]	S22 [MAG]	S22 [ANG.]
1	0.92	-64.25	13.19	141.20	0.033	56.560	0.46	-36.52
2	0.87	-105.65	9.68	117.34	0.048	37.422	0.37	-58.58
3	0.84	-131.06	7.33	101.49	0.053	27.876	0.32	-72.07
4	0.83	-149.30	5.79	89.56	0.055	21.285	0.29	-80.80
5	0.82	-162.29	4.75	79.77	0.055	17.345	0.28	-88.81
6	0.82	-172.56	4.00	71.40	0.055	14.429	0.28	-93.34
7	0.82	177.98	3.44	63.68	0.054	12.980	0.29	-97.85
8	0.83	170.03	2.99	56.43	0.053	11.367	0.29	-103.15
9	0.83	162.91	2.64	49.71	0.051	10.094	0.30	-106.98
10	0.84	155.83	2.33	43.12	0.049	8.831	0.31	-111.51
11	0.85	150.15	2.08	37.02	0.048	9.020	0.33	-116.26
12	0.86	146.03	1.86	31.78	0.046	9.038	0.34	-119.38
13	0.87	141.12	1.67	26.35	0.045	9.686	0.35	-123.53
14	0.89	137.47	1.52	21.34	0.045	9.837	0.37	-128.98
15	0.90	134.65	1.39	17.24	0.045	11.047	0.38	-131.05
16	0.91	131.13	1.28	12.51	0.046	11.134	0.40	-134.67
17	0.92	127.82	1.19	7.56	0.047	10.856	0.42	-138.64
18	0.92	125.14	1.10	2.79	0.047	9.956	0.44	-141.24
19	0.93	120.98	1.02	-2.09	0.049	9.789	0.45	-143.25
20	0.93	119.34	0.95	-6.78	0.051	7.389	0.47	-147.74
21	0.93	117.00	0.88	-10.66	0.051	8.789	0.48	-150.89
22	0.92	114.60	0.81	-14.89	0.054	8.633	0.49	-154.89
23	0.93	113.16	0.76	-18.59	0.055	9.580	0.52	-158.03
24	0.92	111.43	0.70	-22.44	0.056	9.195	0.52	-161.04
25	0.92	109.91	0.64	-25.94	0.055	11.221	0.54	-165.44
26	0.93	109.66	0.59	-28.89	0.056	15.488	0.55	-168.02

Note: S-parameters include bond wires. Reference planes are at edge of substrates shown on "Wire Bonding Information" figure below.

## Wire Bonding Information

Follow the wire bonding diagrams recommended by BeRex below to achieve optimum device performance. BeRex recommends thermo-compression wedge bonding. As a general rule, bonding temperature should be kept to a maximum of 280°C for no longer than 2 minutes for all bonding wires. Ultrasonic bonding is not recommended.

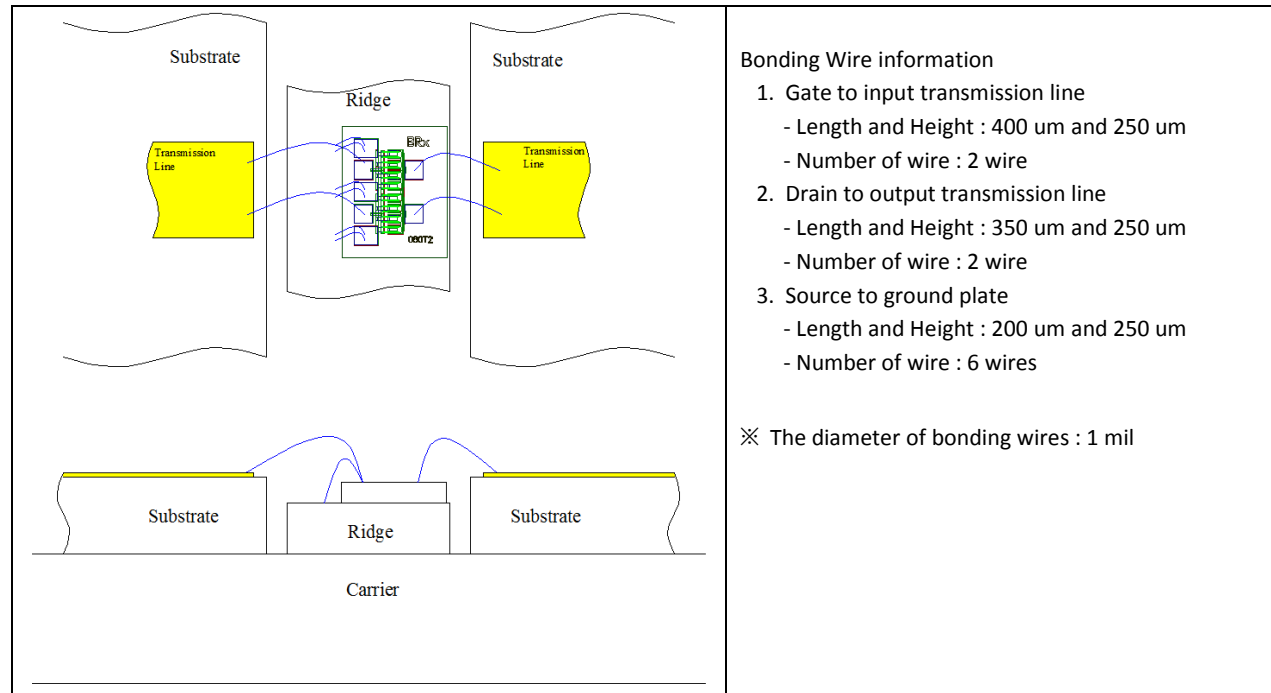

Proper ESD procedures should be followed when handling this device.

### DIE ATTACH RECOMMENDATIONS:

BeRex recommends the "Eutectic" die attach using Au-Sn (80%-20%) pre-forms. The die attach station must have accurate temperature control, and the operation should be performed with parts no hotter than 300°C for less than 10 seconds. An inert forming gas (90% N<sub>2</sub>-10% H<sub>2</sub>) or clean, dry N<sub>2</sub> should be used.

### HANDLING PRECAUTIONS:

GaAs FETs are very sensitive to and may be damaged by Electrostatic Discharge (ESD). Therefore, proper ESD precautions must be taken whenever you are handling these devices. It is critically important that all work surfaces, and assembly equipment, as well as the operator be properly grounded when handling these devices to prevent ESD damage.

### STORAGE & SHIPPING:

BeRex's standard chip device shipping package consists of an antistatic "Gel-Pak", holding the chips, placed inside a sealed antistatic and moisture barrier bag. This packaging is designed to provide a reasonable measure of protection from both mechanical and ESD damage.

Chip devices should be stored in a clean, dry Nitrogen gas environment at room temperature until they are required for assembly. Only open the shipping package or perform die assembly in a work area with a class 10,000 or better clean room environment to prevent contamination of the exposed devices.

**CAUTION:**

THIS PRODUCT CONTAINS GALLIUM ARSENIDE (GaAs) WHICH CAN BE HAZARDOUS TO THE HUMAN BODY AND THE ENVIRONMENT. THEREFORE, IT MUST BE HANDLED WITH CARE AND IN ACCORDANCE WITH ALL GOVERNMENTAL AND COMPANY REGULATIONS FOR THE SAFE HANDLING AND DISPOSAL OF HAZARDOUS WASTE. DO NOT BURN, DESTROY, CUT, CRUSH OR CHEMICALLY DISSOLVE THE PRODUCT. DO NOT LICK THE PRODUCT OR IN ANY WAY ALLOW IT TO ENTER THE MOUTH. EXCLUDE THE PRODUCT FROM GENERAL INDUSTRIAL WASTE OR GARBAGE AND DISPOSE OF ONLY IN ACCORDANCE TO APPLICABLE LAWS AND/OR ORDINANCES

**DISCLAIMER**

BEREX RESERVES THE RIGHT TO MAKE CHANGES WITHOUT FURTHER NOTICE TO ANY PRODUCTS HEREIN TO IMPROVE RELIABILITY, FUNCTION OR DESIGN. BEREX DOES NOT ASSUME ANY LIABILITY ARISING OUT OF THE APPLICATION OR USE OF ANY PRODUCT OR CIRCUIT DESCRIBED HEREIN.

**LIFE SUPPORT POLICY**

BEREX PRODUCTS ARE NOT AUTHORIZED FOR USE AS CRITICAL COMPONENTS IN LIFE SUPPORT DEVICES WITHOUT THE EXPRESS WRITTEN APPROVAL OF BEREX.

1. Life support devices or systems are devices or systems which (a) are intended for surgical implant into the body, or (b) support or sustain life, or (c) whose failure to perform when properly used in accordance with instructions for use provided in labeling, can be reasonably expected to result in significant injury to the user.
2. A critical component is any component of a life support device or system whose failure to perform can be reasonably expected to cause the failure of the life support device or system, or to affect its safety or effectiveness.

**RoHS COMPLIANT**

For complete specifications, S-parameters and information on bonding and handling, visited our website; [www.berex.com](http://www.berex.com)