

KR Electronics, Inc.

General Description

KR Electronics part number 2955 is a 1500 MHz bandpass filter. The filter has a minimum 1 dB bandwidth of 200 MHz. Other center frequencies and bandwidths available. Please consult the factory.

Features

- 1500 MHz Center Frequency
- 1400 MHz to 1600 MHz Passband
- 50 Ω Source and Load
- Surface Mount

Typical Performance

Overall Response (10 dB/div)



KR Electronics, Inc.
91 Avenel Street
Avenel, NJ 07001

Web www.krfilters.com
Email sales@krfilters.com
Phone (732) 636-1900
Fax (732) 636-1982

Typical Performance

Passband Amplitude & Group Delay (1 dB/div & 0.5 nsec/div)

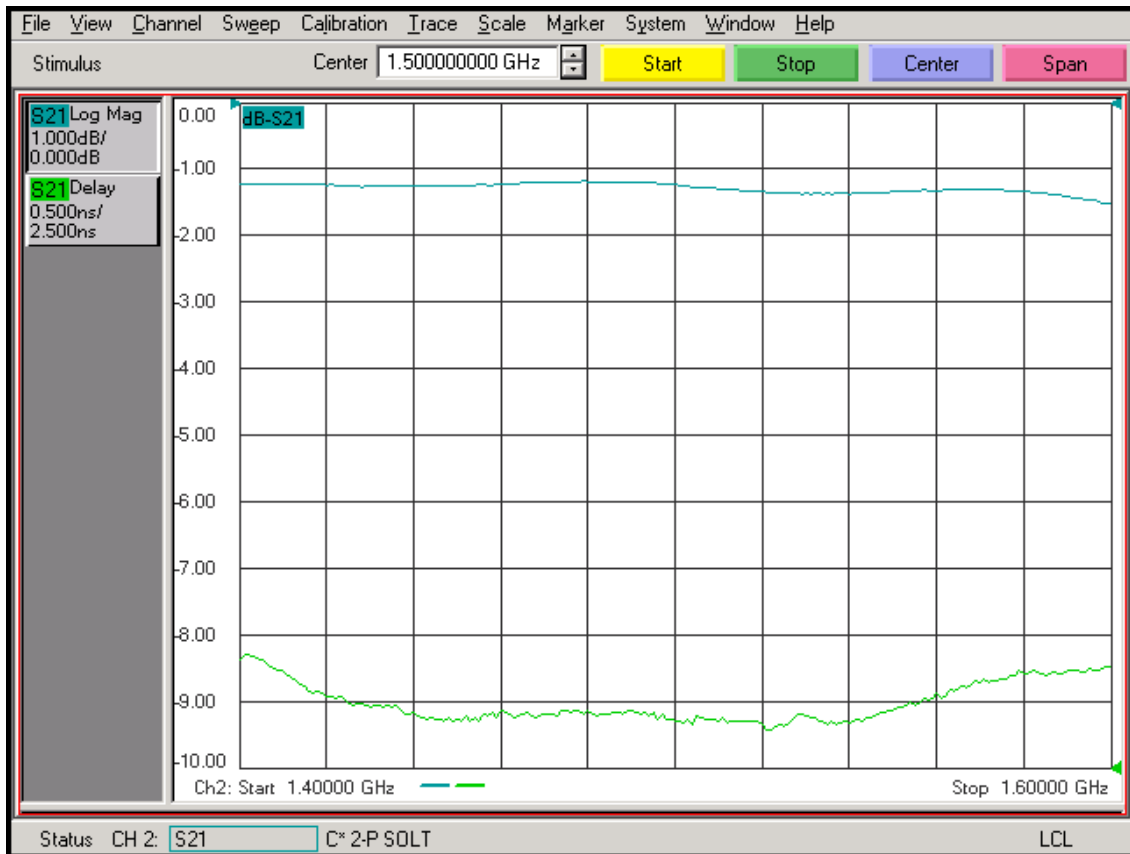

KR Electronics 2955

Specifications

Parameter	Specification	
Filter type	Bandpass	
Center Frequency	1500 MHz	
Insertion Loss	2 dB max	1.2 dB typical
1 dB Bandwidth	200 MHz min	300 MHz typical
20 dB Bandwidth	590 MHz typical	
40 dB Bandwidth	1045 MHz typical	
Source and Load	50 Ω	

Physical Dimensions

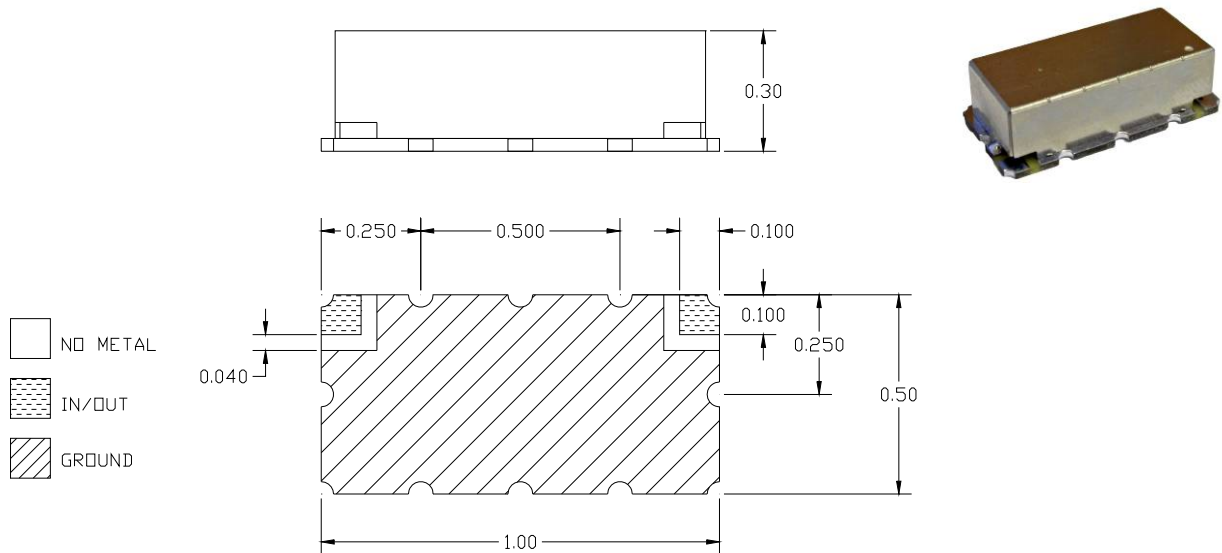

Notes:

1. Surface mount package
2. Dimensions in inches
3. Max reflow temperature 209° C for 10 sec
4. If boards are cleaned after installation units must be completely dried

KR Electronics, Inc.
91 Avenel Street
Avenel, NJ 07001

Web www.krfilters.com
Email sales@krfilters.com
Phone (732) 636-1900
Fax (732) 636-1982