

Low Noise Amplifier

TAMP-362GLN+

50Ω 3300 to 3600 MHz

The Big Deal

- Ultra Low Noise Figure, 0.9 dB typ.
- High Output IP3, 29 dBm typ.
- Integrated Bias Matching and Stabilization Circuits

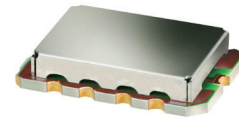

CASE STYLE: JQ1382

Product Overview

The TAMP-362GLN+ (RoHS compliant) utilizes advanced E-PHEMT technology in a 2-stage low noise amplifier design built into a shielded case (size: .591"x.394"x.118"). The drop-in module offers ultra low noise figure and high output IP3 with good input and output return loss over the entire frequency range and without the need of external matching components.

Key Features

Feature	Advantages
Ultra Low NF	With typ. 0.9 dB NF, the TAMP-362GLN+ enables greater sensitivity for receiver applications. It includes all matching and stability circuits making this Drop-in LNA module a turn-key solution for ensuring low system sensitivity in demanding applications.
High Output IP3	At +29 dBm IP3, in combination with its low noise performance, the TAMP-242GLN+ can improve a systems' spur-free dynamic range which is often the critical driver in many receiver applications.
Well Matched input/ output ports	With typical input & output VSWR of 1.3:1, the TAMP-362GLN+ can be used in cascade with many 50 Ohm components and maintain minimal interaction or reflections.
Max Input Power, +15dBm	Ruggedized design operates up to input powers of +15dBm without the need of an external limiter.
Drop-in Module	Eliminates the need for designers to optimize low noise transistor bias and matching circuitry. The TAMP-362GLN+ provides the outstanding combined performance and does not require any external elements. The case PCB area is smaller than most LNA transistor designs with external circuitry.
Metal Case	Provides a protective enclosure improving handling robustness in addition to shielding the sensitive high gain devices from close by circuitry.
Unconditionally stable	No adverse effects due to reactive loads at the input and output ports avoiding potential instability which can be a critical requirement when integrating high gain, high frequency devices on an open PCB assembly.



For detailed performance specs & shopping online see web site

P.O. Box 350166, Brooklyn, New York 11235-0003 (718) 934-4500 Fax (718) 332-4661 The Design Engineers Search Engine  Provides ACTUAL Data Instantly at minicircuits.com

Notes: 1. Performance and quality attributes and conditions not expressly stated in this specification sheet are intended to be excluded and do not form a part of this specification sheet. 2. Electrical specifications and performance data contained herein are based on Mini-Circuit's applicable established test performance criteria and measurement instructions. 3. The parts covered by this specification sheet are subject to Mini-Circuits standard limited warranty and terms and conditions (collectively, "Standard Terms"); Purchasers of this part are entitled to the rights and benefits contained therein. For a full statement of the Standard Terms and the exclusive rights and remedies thereunder, please visit Mini-Circuits' website at www.minicircuits.com/MCLStore/terms.jsp.

Surface Mount

Low Noise Amplifier

TAMP-362GLN+

50Ω

3300 to 3600 MHz

Features

- Ultra low noise figure, 0.9 dB typ.
- Output power, up to +16 dBm typ.
- Good output IP3, 29 dBm typ.
- Good VSWR, 1.3:1 typ.
- Unconditionally stable

Applications

- WiMAX
- Defence system radar
- Base station transceiver, tower mounted amplifier, repeater
- General purpose low noise amplifier

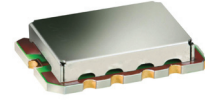

CASE STYLE: JQ1382
 PRICE: \$14.95 ea. QTY (5-49)

+RoHS Compliant
 The +Suffix identifies RoHS Compliance. See our web site for RoHS Compliance methodologies and qualifications

Electrical Specifications at 25°C

Parameter	Condition (MHz)	Min.	Typ.	Max.	Units
Frequency Range		3300		3600	MHz
Noise Figure	3300 - 3600		0.9	1.2	dB
Gain	3300 - 3600	18	20		dB
Gain Flatness	3300 - 3600		± 0.3	± 0.6	dB
Output Power at 1dB compression	3300 - 3600	13	16		dBm
Output third order intercept point (OIP3)	3300 - 3600		29		dBm
Input VSWR	3300 - 3600		1.3		:1
Output VSWR	3300 - 3600		1.3		:1
DC Supply Voltage			5.0		V
DC Supply Current			100	140	mA

Pin Connections

RF IN	10
RF OUT	5
V+	7
GROUND	1,2,3,4,6,8,9,11

Maximum Ratings

Parameter	Ratings
Operating Temperature	-40°C to 85°C
Storage Temperature	-55°C to 100°C
Operating Voltage	5.5 V
Input RF Power (no damage)	+15 dBm
Power Consumption	800 mW

Permanent damage may occur if any of these limits are exceeded.

Simplified Schematic

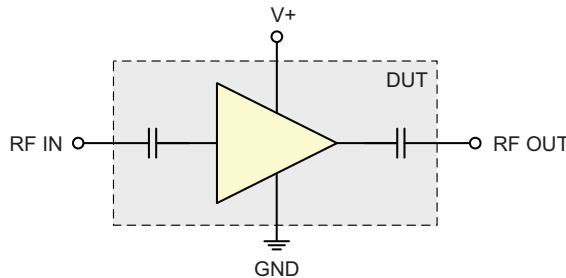

ESD Rating

Human Body Model (HBM): Class 1A (250 V to < 500 V) in accordance with ANSI/ESD STM 5.1 - 2001

Machine Model (MM): Class M1 (40 V) in accordance with ANSI/ESD STM 5.2 - 1999



P.O. Box 350166, Brooklyn, New York 11235-0003 (718) 934-4500 Fax (718) 332-4661 The Design Engineers Search Engine Provides ACTUAL Data Instantly at minicircuits.com

For detailed performance specs & shopping online see web site

Notes: 1. Performance and quality attributes and conditions not expressly stated in this specification sheet are intended to be excluded and do not form a part of this specification sheet. 2. Electrical specifications and performance data contained herein are based on Mini-Circuit's applicable established test performance criteria and measurement instructions. 3. The parts covered by this specification sheet are subject to Mini-Circuits standard limited warranty and terms and conditions (collectively, "Standard Terms"); Purchasers of this part are entitled to the rights and benefits contained therein. For a full statement of the Standard Terms and the exclusive rights and remedies thereunder, please visit Mini-Circuits' website at www.minicircuits.com/MCLStore/terms.jsp.

REV. A
 M130109
 TAMP-362GLN+
 EDR-9679/8F1
 RAV
 121022
 Page 2 of 4

Outline Drawing

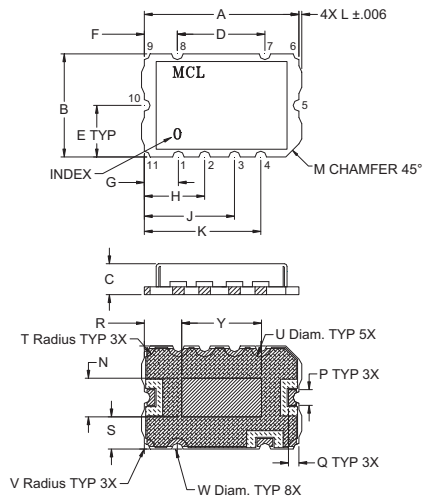

PCB Land Pattern

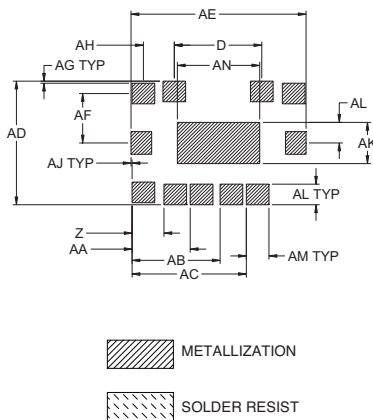

Outline Dimensions (inch/mm)

A	B	C	D	E	F	G	H	J	K	L	M	N	P	Q	R	S	T	U	wt.	
.591	.394	.118	.335	.197	.126	.130	.230	.344	.445	.011	.050	.148	.060	.040	.143	.123	.042	.084		
15.0	10.0	3.0	8.5	5.0	3.2	3.3	5.85	8.75	11.3	.28	1.27	3.75	1.52	1.02	3.63	3.13	1.07	2.13		
V	W	Y	Z	AA	AB	AC	AD	AE	AF	AG	AH	AJ	AK	AL	AM	AN				grams
.022	.044	.305	.122	.222	.337	.437	.472	.669	.189	.008	.118	.004	.158	.079	.087	.315				0.8
.56	1.12	7.75	3.1	5.65	8.55	11.1	12.0	17.0	4.8	.20	3.0	.10	4.0	2.0	2.2	8.0				

Demo Board MCL P/N: TB-468+ Suggested PCB Layout (PL-293)

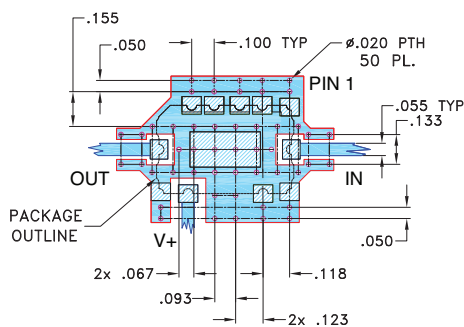

NOTES:

- TRACE WIDTH IS SHOWN FOR ROGERS RO4350B WITH DIELECTRIC THICKNESS .030" ± .002; COPPER 1/2 OZ. EACH SIDE. FOR OTHER MATERIALS TRACE WIDTH MAY NEED TO BE MODIFIED.
- BOTTOM SIDE OF THE PCB IS CONTINUOUS GROUND PLANE.

- DENOTES PCB COPPER LAYOUT WITH SMOBC (SOLDER MASK OVER BARE COPPER)
- DENOTES COPPER LAND PATTERN FREE OF SOLDER MASK

FREQUENCY (MHz)	GAIN (dB)	DIRECTIVITY (dB)	VSWR IN (:1)	VSWR OUT (:1)	NOISE FIGURE (dB)	P. OUT @ 1dB COMPR. (dBm)	OUTPUT IP3 (dBm)
3300.00	20.24	22.19	1.32	1.15	0.99	15.99	29.43
3320.00	20.30	22.05	1.33	1.16	0.99	16.05	29.48
3330.00	20.28	22.35	1.35	1.17	1.00	16.09	28.99
3350.00	20.28	22.02	1.33	1.18	0.99	16.04	29.28
3360.00	20.28	21.72	1.34	1.17	0.99	16.03	29.31
3380.00	20.28	22.37	1.33	1.19	0.98	16.05	29.29
3400.00	20.32	22.29	1.32	1.21	0.98	15.98	28.84
3410.00	20.35	22.15	1.32	1.22	0.97	15.93	29.49
3430.00	20.36	21.98	1.31	1.23	0.97	16.02	29.65
3450.00	20.41	21.43	1.32	1.24	0.97	16.26	29.66
3470.00	20.37	20.84	1.32	1.24	0.97	16.11	29.50
3480.00	20.39	21.21	1.31	1.25	0.98	15.97	30.12
3500.00	20.50	20.69	1.31	1.26	0.99	16.00	29.77
3520.00	20.46	19.90	1.34	1.25	1.00	16.35	29.78
3530.00	20.41	20.01	1.34	1.23	1.00	16.33	29.46
3550.00	20.49	21.45	1.30	1.27	1.00	16.16	30.20
3560.00	20.56	21.36	1.29	1.29	1.01	16.12	29.72
3580.00	20.57	21.07	1.30	1.29	1.02	16.27	29.86
3590.00	20.69	21.36	1.29	1.33	1.02	16.31	29.65
3600.00	20.70	20.55	1.30	1.34	1.02	16.32	29.80

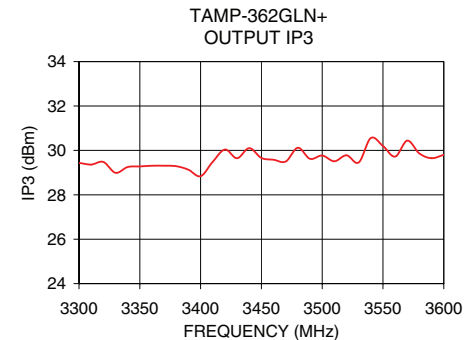
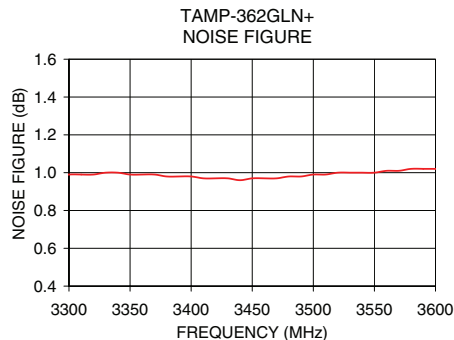
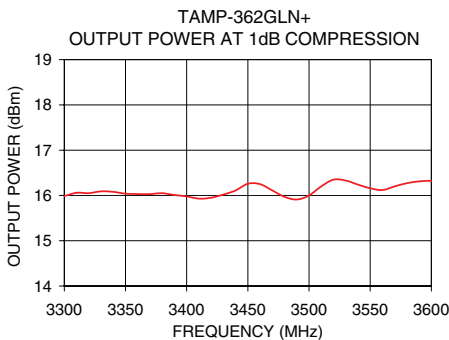
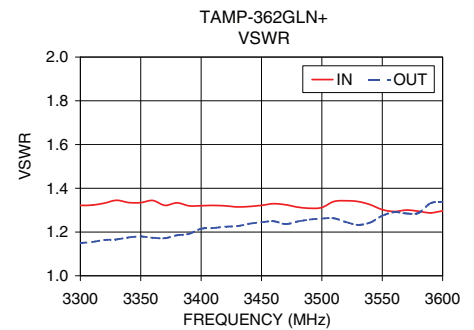
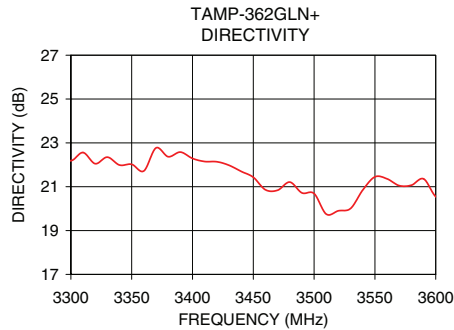
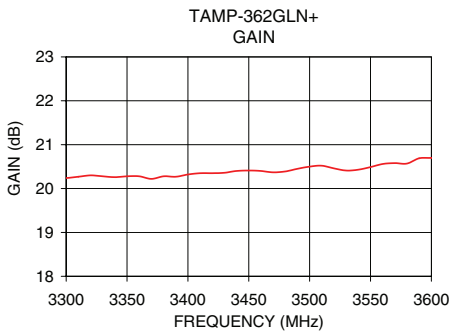

For detailed performance specs & shopping online see web site

P.O. Box 350166, Brooklyn, New York 11235-0003 (718) 934-4500 Fax (718) 332-4661 The Design Engineers Search Engine Provides ACTUAL Data Instantly at minicircuits.com

IF/RF MICROWAVE COMPONENTS

Notes: 1. Performance and quality attributes and conditions not expressly stated in this specification sheet are intended to be excluded and do not form a part of this specification sheet. 2. Electrical specifications and performance data contained herein are based on Mini-Circuit's applicable established test performance criteria and measurement instructions. 3. The parts covered by this specification sheet are subject to Mini-Circuits standard limited warranty and terms and conditions (collectively, "Standard Terms"); Purchasers of this part are entitled to the rights and benefits contained therein. For a full statement of the Standard Terms and the exclusive rights and remedies thereunder, please visit Mini-Circuits' website at www.minicircuits.com/MCLStore/terms.jsp.