

- 110.592 MHz Narrow-band SAW Filter
- Steep Transition to Stopband
- Hermetic 5 X 7 mm Surface Mount Case
- Complies with Directive 2002/95/EC (RoHS)

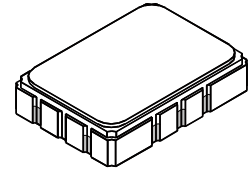

SF1056B

**110.592 MHz
SAW Filter**



SMP-03

Absolute Maximum Ratings

Rating	Value	Units
Incident Power in Passband	+10	dBm
DC Voltage on any Non-ground Terminal	3	VDC
Operating Temperature Range	-40 to +80	°C
Storage Temperature Range in Tape and Reel	-40 to +85	°C
Soldering Profile, 5 Cycles Maximum	265 °C for 10 s	

Electrical Characteristics

Characteristic	Sym	Notes	Min	Typ	Max	Units
Center Frequency	F_C			110.592		MHz
Insertion Loss	IL			8.6	10.0	dB
3 dB Bandwidth	BW_3		1.152	1.44		MHz
Group Delay Ripple, 110.016 to 111.168 MHz				150	200	ns _{P-P}
40 dB Bandwidth	BW_{40}			6.7	7.0	MHz
Rejection:						dB
DC to 107.192 MHz			38	42		
107.192 to 108.864 MHz			28	42		
112.320 to 113.992 MHz			28	34		
113.992 to 200 MHz			38	42		
Source Impedance for L-L Matching Network				50		ohm
Load Impedance for L-L Matching Network				50		ohm
Case Style	SMP-03 5 x 7 mm Nominal Footprint					
Lid Symbolization (Y=year, WW=week, S=shift) See note 3	RFM SF1056B YWWS					



CAUTION: Electrostatic Sensitive Device. Observe precautions for handling.

NOTES:

1. Unless noted otherwise, all specifications apply over the operating temperature range with filter soldered to the specified demonstration board with impedance matching to 50 Ω and measured with 50 Ω network analyzer. A dB offset exists for RFM because of the loss introduced by using transformers on the Input and Output.
2. Rejection is measured as attenuation below the minimum IL point in the passband. Rejection in final user application is dependent on PCB layout and external impedance matching design. See Application Note No. 42 for details.
3. "LRIP" or "L" after the part number indicates "low rate initial production" and "ENG" or "E" indicates "engineering prototypes."
4. The design, manufacturing process, and specifications of this filter are subject to change.
5. Either Port 1 or Port 2 may be used for either input or output in the design. However, impedances and impedance matching may vary between Port 1 and Port 2, so that the filter must always be installed in one direction per the circuit design.
6. US and international patents may apply.
7. Murata, stylized Murata logo, and Murata N.A., Inc. are registered trademarks of Murata Manufacturing Co., Ltd

Filter Passband Plot

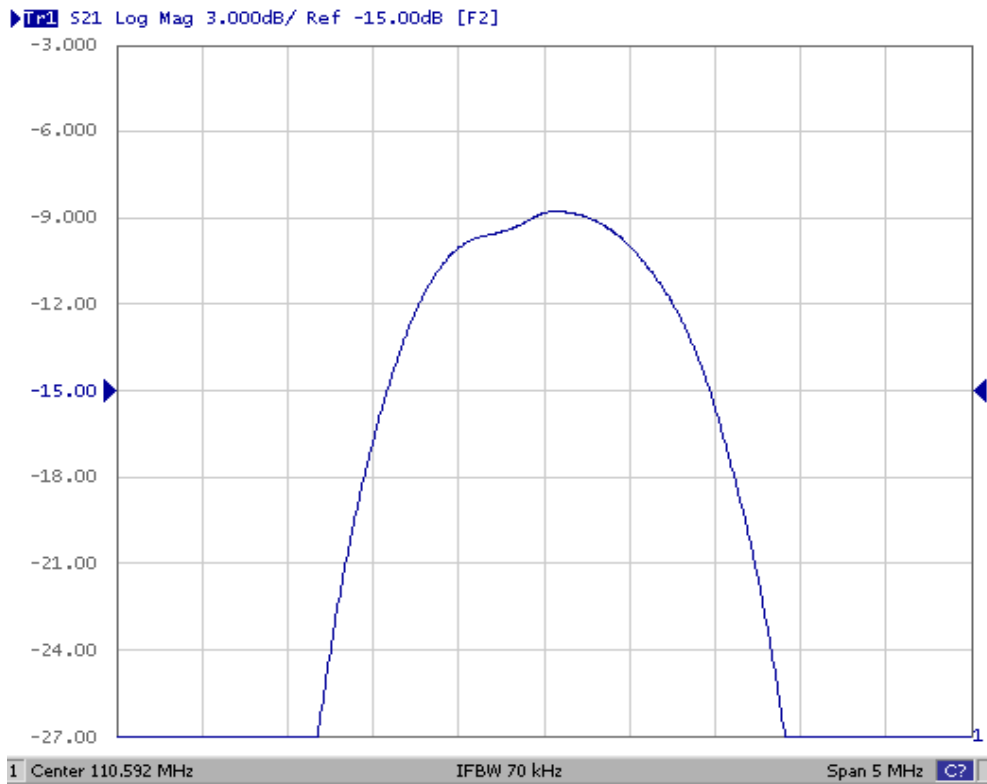

Filter Transition Bandwidth Plot

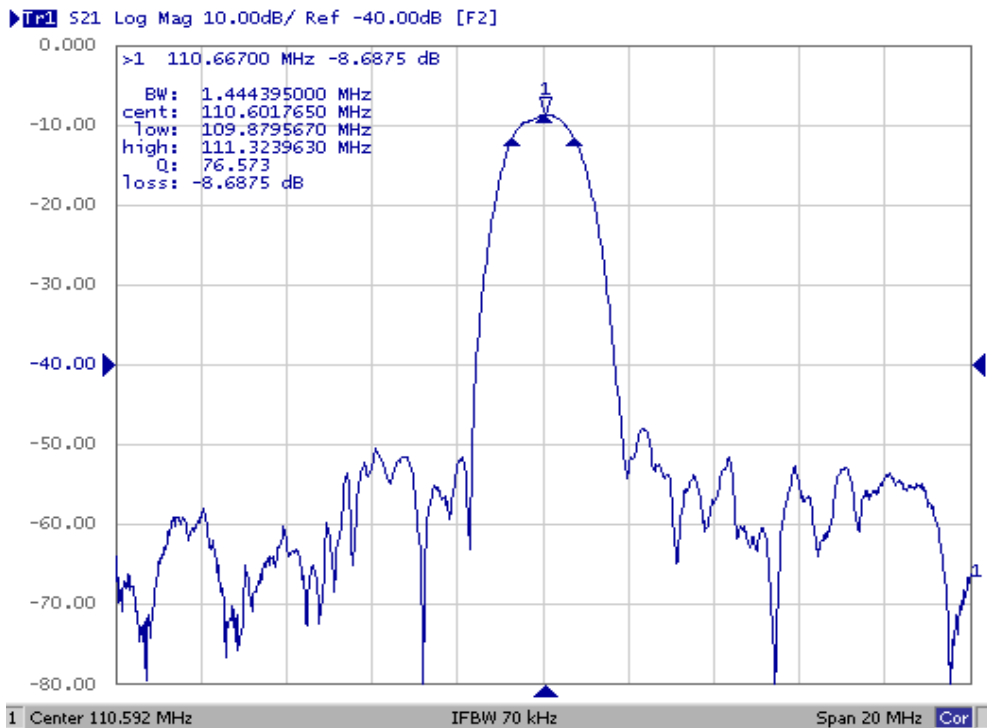

Filter Group Delay Plot

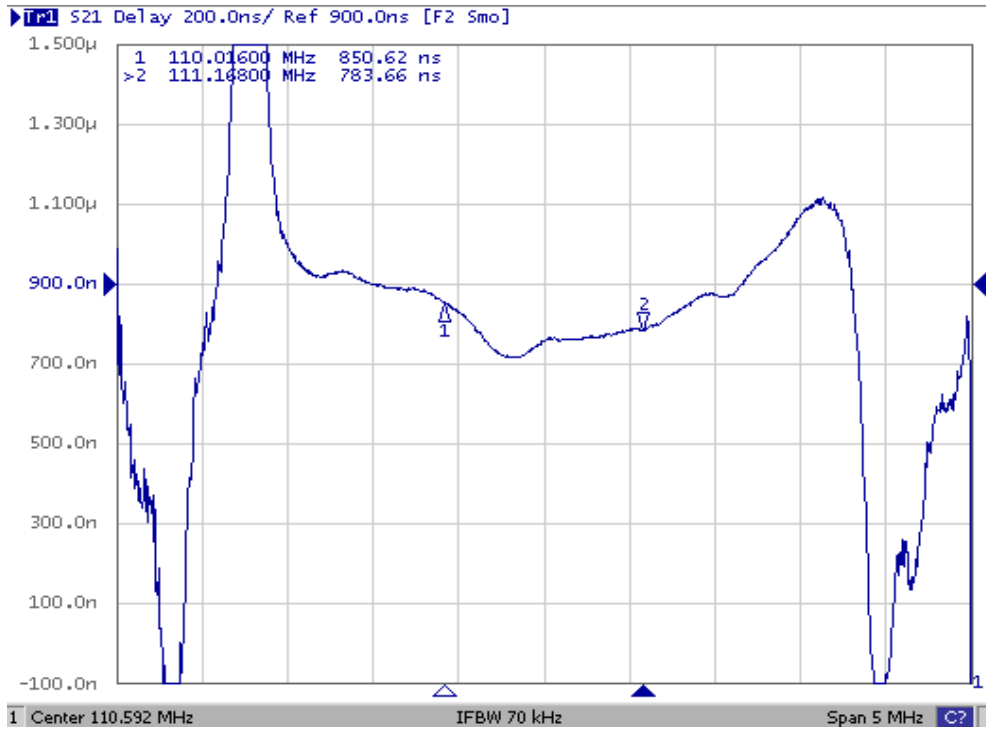

Demonstration Circuit

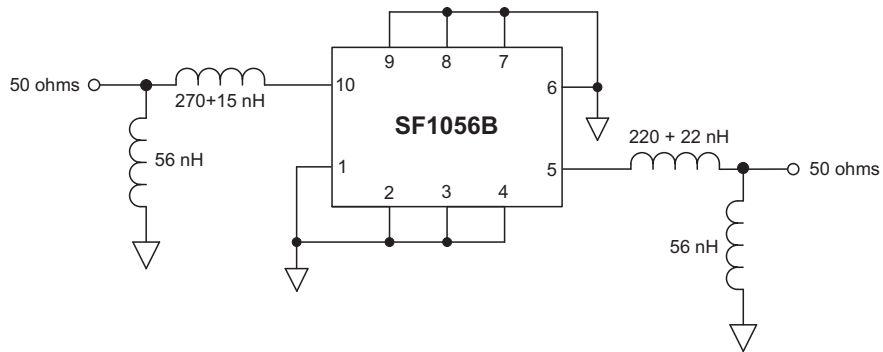

SMP-03 Case

10-Terminal Ceramic Surface-Mount Case 5 x 7 mm Nominal Footprint

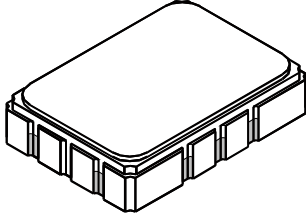

Recommended PCB Footprint

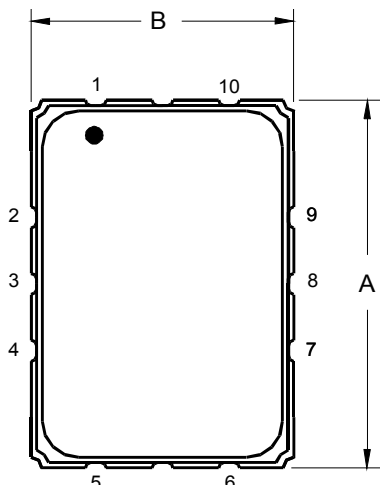
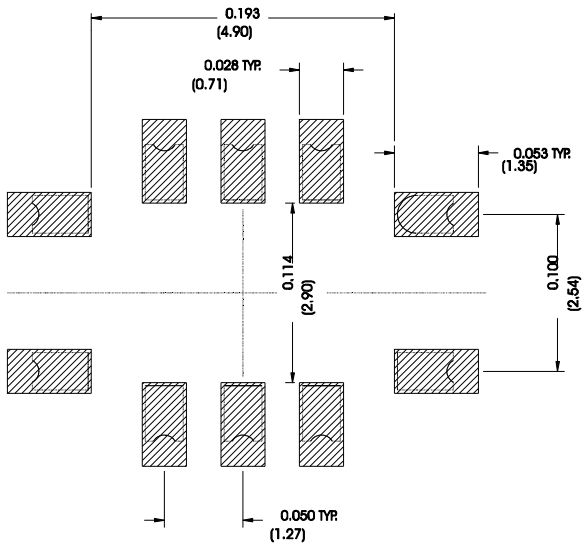

TOP VIEW

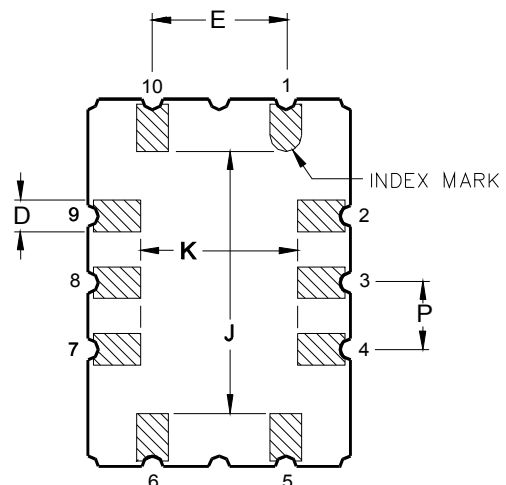
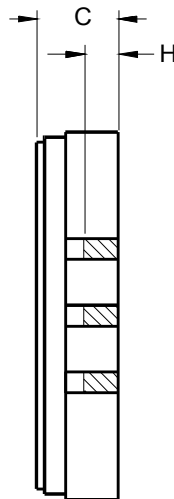

BOTTOM VIEW

Case Dimensions

Dimension	mm			Inches		
	Min	Nom	Max	Min	Nom	Max
A	6.80	7.00	7.20	0.268	0.276	0.283
B	4.80	5.00	5.20	0.189	0.197	0.205
C		1.65	2.00		0.065	0.079
D	.47	0.60	.73	0.019	0.024	0.029
E	2.41	2.54	2.67	0.095	0.100	0.105
H	0.87	1.0	1.13	0.034	0.039	0.044
J	0.87	1.0	1.13	0.034	0.039	0.044
K	4.87	5.00	5.13	0.192	0.197	0.202
P	2.87	3.00	3.13	0.113	0.118	0.123

Electrical Connections

Connection		Terminals
Port 1	Balanced Input	1
	Balanced Input	10
Port 2	Balanced Output	5
	Balanced Output	6
Ground		All others

Case Materials

Materials	
Solder Pad Plating	0.3 to 1.0 μm Gold over 1.27 to 8.89 μm Nickel
Lid Plating	2.0 to 3.0 μm Nickel
Body	Al_2O_3 Ceramic
Pb Free	

Tape and Reel Specifications

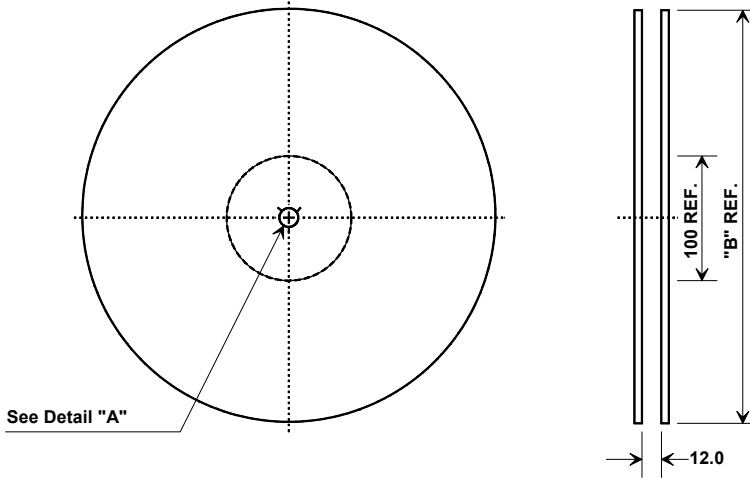

"B"		Quantity Per Reel
Nominal Size		
Inches	millimeters	
7	178	500
13	330	2000

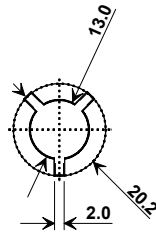

COMPONENT ORIENTATION and DIMENSIONS

Carrier Tape Dimensions	
Ao	9.4 mm
Bo	7.4 mm
Ko	2.0 mm
Pitch	8.0 mm
W	16.0 mm

