

- Precision SAW Filter
- 3.8 x 3.8 x 1.2 mm Surface-mount Case
- Differential or Single-ended Operation
- Complies with Directive 2002/95/EC (RoHS)



Absolute Maximum Ratings

Rating	Value	Units
Maximum Incident Power in Passband	+10	dBm
Maximum DC Voltage Between any Two Terminals	30	VDC
Storage Temperature Range in Tape and Reel	-40 to +85	°C
Suitable for Lead-free Soldering - Maximum Soldering Profile	260 °C for 30 s	

SF2125D

**305.00 MHz
SAW Filter**

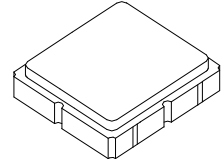

SM3838-8

Electrical Characteristics

Characteristic	Sym	Notes	Min	Typ	Max	Units
Center Frequency	f_C	1		305		MHz
Insertion Loss	IL			8.5	11.5	dB
3 dB Bandwidth	BW_3		5	7.5		MHz
40 dB Bandwidth	BW_{40}			14	26	MHz
Amplitude Ripple, p-p, $f_C \pm 2.5$ MHz				0.7	1.5	dB
Low Side Attenuation, $f_C - 8.2$ MHz			30			dB
Low Side Attenuation, $f_C - 7.8$ MHz			25			
High Side Attenuation, $f_C + 7.8$ MHz			25			
High Side Attenuation, $f_C + 8.2$ MHz			30			
Temperature Coefficient of Frequency					-18	ppm/K
Delay Ripple, p-p, $f_C \pm 2.5$ MHz		1, 2, 3			50	ns
Group Delay in Passband					350	
Case Style		6	SM3838-8 3.8 x 3.8 mm Nominal Footprint			
Lid Symbolization, Y=year, WW=week, S=shift			TBD YWWS			



CAUTION: Electrostatic Sensitive Device. Observe precautions for handling.

NOTES:

1. Unless noted otherwise, all specifications apply over the operating temperature range with filter soldered to the specified demonstration board with impedance matching to 50 Ω and measured with 50 Ω network analyzer.
2. Unless noted otherwise, all frequency specifications are referenced to the nominal center frequency, f_C .
3. Rejection is measured as attenuation below the minimum IL point in the passband. Rejection in final user application is dependent on PCB layout and external impedance matching design. See Application Note No. 42 for details.
4. The design, manufacturing process, and specifications of this filter are subject to change.
5. Tape and Reel Standard Per ANSI / EIA 481.
6. US and international patents may apply.
7. Murata, stylized Murata logo, and Murata N.A., Inc. are registered trademarks of Murata Manufacturing Co., Ltd.

Single-ended Demonstration Circuit

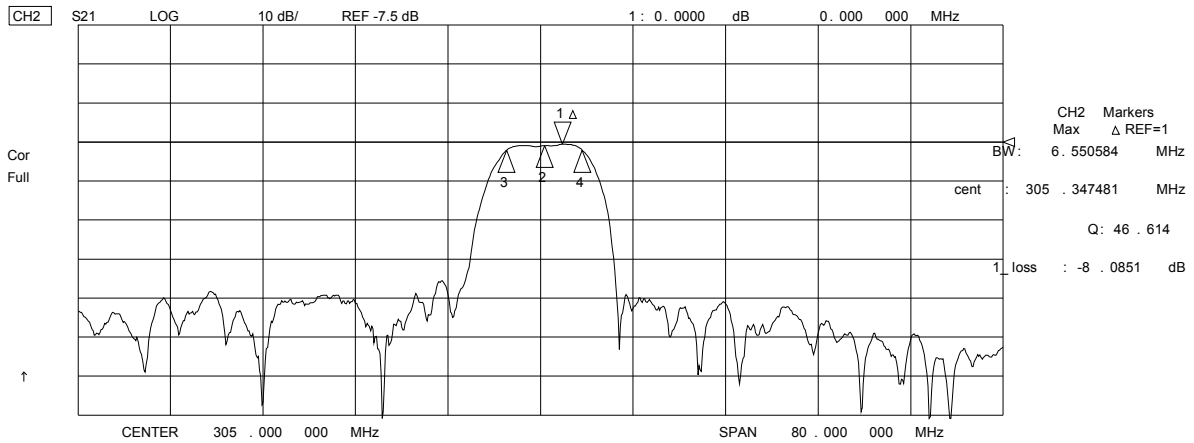
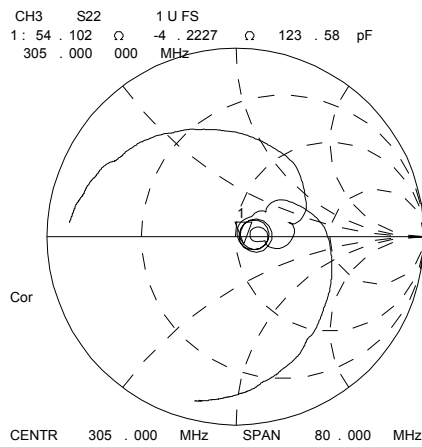
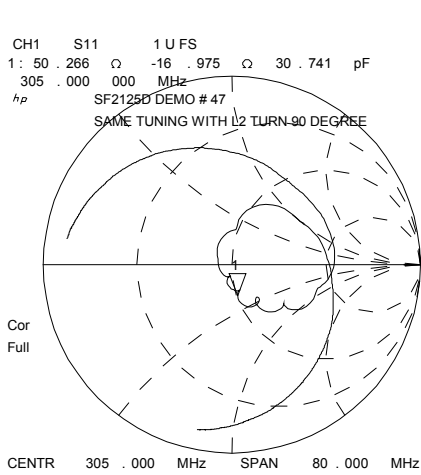
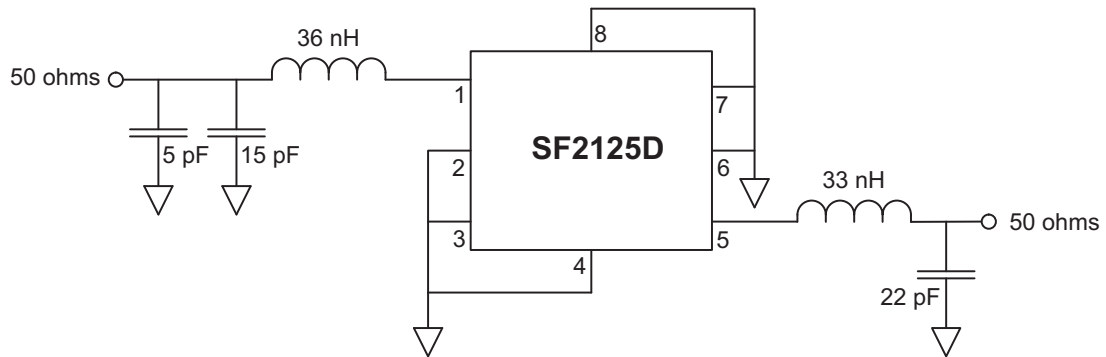

Balanced Demonstration Circuit

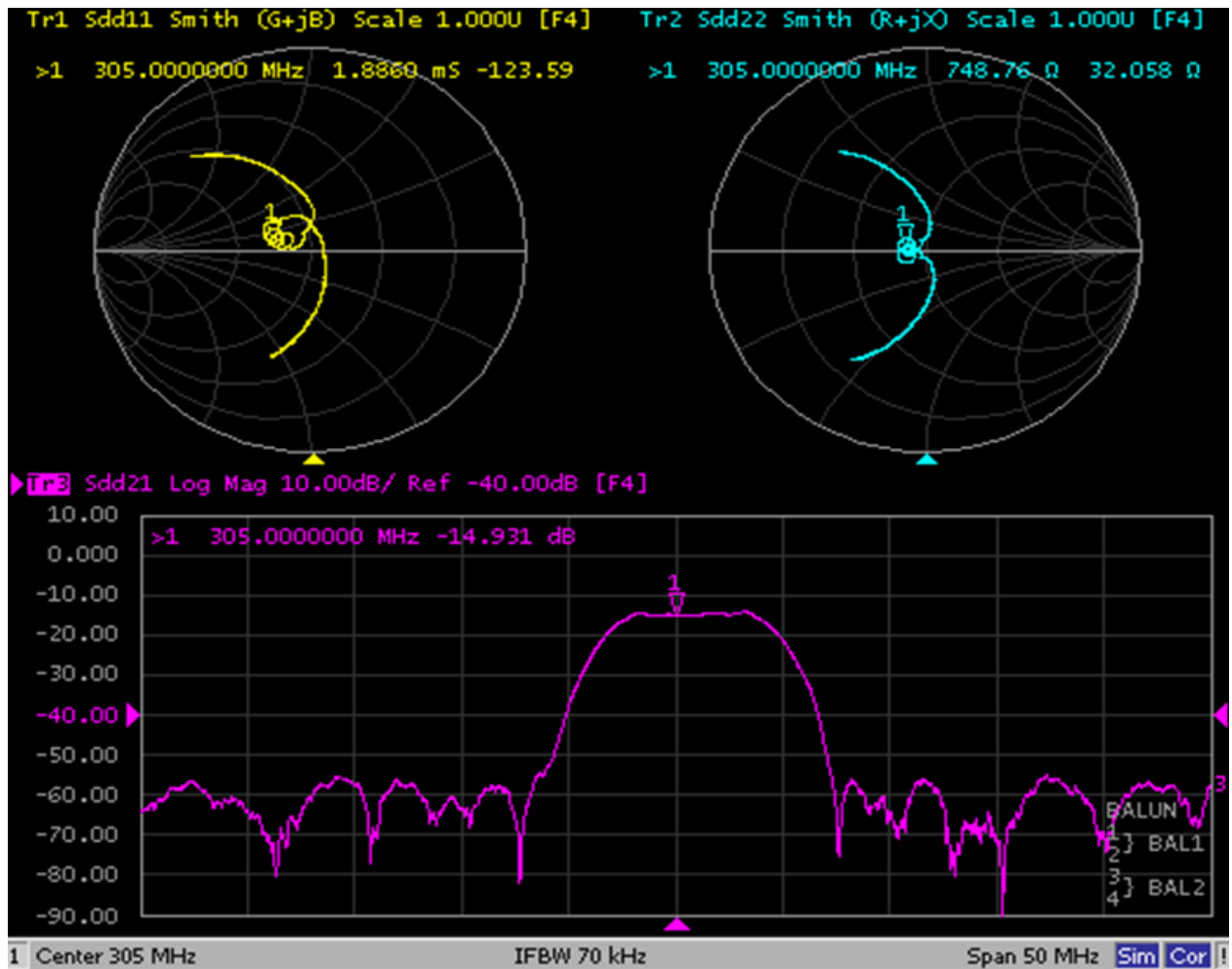
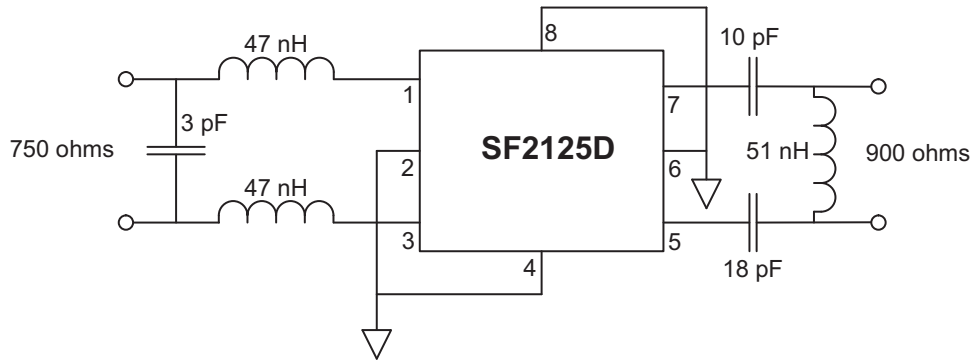

SM3838-8 Case

8-Terminal Ceramic Surface-Mount Case

3.8 x 3.8 mm Nominal Footprint

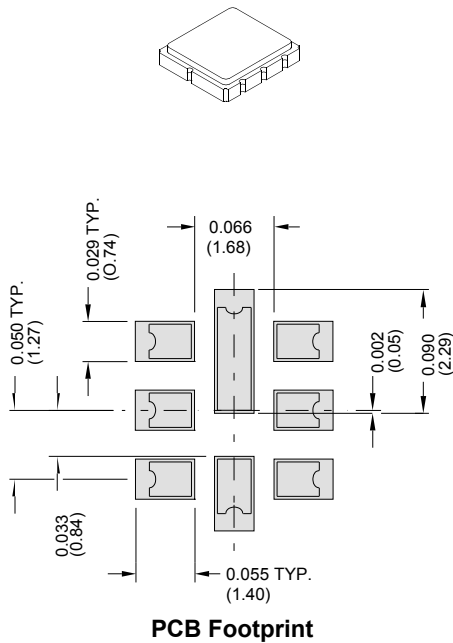

Case Dimensions

Dimension	mm			Inches		
	Min	Nom	Max	Min	Nom	Max
A	3.6	3.8	4.0	0.142	0.150	0.157
B	3.6	3.8	4.0	0.142	0.150	0.157
C	1.05	1.20	1.35	0.041	0.047	0.053
D	0.95	1.10	1.25	0.037	0.043	0.049
E	0.90	1.00	1.10	0.035	0.040	0.043
F	0.50	0.60	0.70	0.020	0.024	0.028
G	2.39	2.54	2.69	0.090	0.100	0.110
H	1.40	1.75	2.05	0.055	0.069	0.080

Electrical Connections

	Connection	Terminals
Port 1	Differential Input	1, 3
Port 2	Differential Output	5, 7
	Ground	All Others
Single-ended Operation		Return is Ground
Differential Operation		Return is Hot
Dot Indicates Pin 1		

Materials

Solder Pad Plating	0.3 to 1.0 μm Gold over 1.27 to 8.89 μm Nickel
Lid Plating	2.0 to 3.0 μm Nickel
Body	Al_2O_3 Ceramic
Pb Free	

TOP VIEW

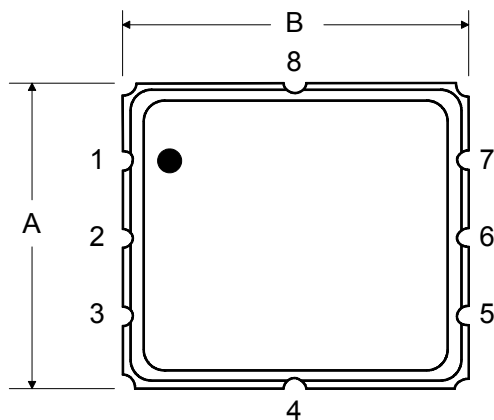

BOTTOM VIEW

