



Features

- Frequency Range 300MHz to 1100MHz
- Full Internal Matching and No External Bias Inductors
- 6-Bit Digital Step Attenuator
- SPI Serial Control Programming
- Gain Control Range = 31.5dB (0.5dB Step Size)
- High OIP3/P1dB = +44/25dBm Typical at 450MHz
- Single +5V Supply
- Small 28-Pin, 6.0mm x 6.0mm, MCM
- Power-up Programming

Applications

- Cellular, 3G Infrastructure
- WiBro, WiMax, LTE
- Microwave Radio
- High Linearity Power Control

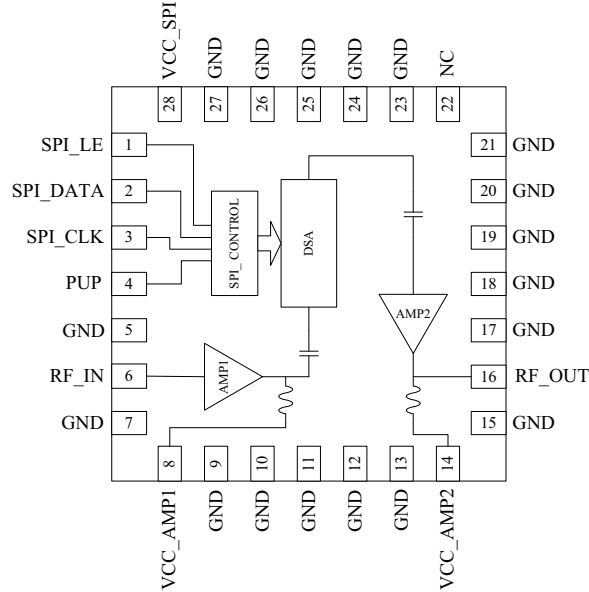

Functional Block Diagram

Product Description

RFMD's RFDA0056 is a digital controlled variable gain amplifier featuring high linearity over the entire gain control range. The gain of the 6-bit digital step attenuator is programmed with a serial mode control interface (SPI). The RFDA0056 is packaged in a small 6.0mm x 6.0mm leadless laminate MCM, which contains plated through thermal vias for ultra-low thermal resistance. This module is easy to use with no external matching components required.

Ordering Information

RFDA0056SQ	Sample bag with 25 pieces
RFDA0056SR	7" Reel with 100 pieces
RFDA0056R7	7" Reel with 750 pieces
RFDA0056R13	13" Reel with 2500 pieces
RFDA0056PCK-410	300MHz to 1100MHz PCBA with 5-piece sample bag

Optimum Technology Matching® Applied

- | | | | |
|---|--------------------------------------|--|------------------------------------|
| <input checked="" type="checkbox"/> GaAs HBT | <input type="checkbox"/> SiGe BiCMOS | <input checked="" type="checkbox"/> GaAs pHEMT | <input type="checkbox"/> GaN HEMT |
| <input type="checkbox"/> GaAs MESFET | <input type="checkbox"/> Si BiCMOS | <input checked="" type="checkbox"/> Si CMOS | <input type="checkbox"/> BiFET HBT |
| <input checked="" type="checkbox"/> InGaP HBT | <input type="checkbox"/> SiGe HBT | <input type="checkbox"/> Si BJT | <input type="checkbox"/> SOI |

RF MICRO DEVICES®, RFMD®, Optimum Technology Matching®, Enabling Wireless Connectivity™, PowerStar®, POLARIS™ TOTAL RADIO™ and UltimateBlue™ are trademarks of RFMD, LLC. BLUETOOTH is a trademark owned by Bluetooth SIG, Inc., U.S.A. and licensed for use by RFMD. All other trade names, trademarks and registered trademarks are the property of their respective owners. ©2012, RF Micro Devices, Inc.

Absolute Maximum Ratings

Parameter	Rating	Unit
Supply Voltage	5.5	V
DC Supply Current	330	mA
Power Dissipation	1600	mW
Max RF Input Power for 50Ω Output Load	12	dBm
Operating Temperature (T _{CASE})	-40 to +85	°C
Storage Temperature	-40 to +150	°C
Junction Temperature	+172	°C
ESD Rating (HBM)	500 (Class 1B)	V
Moisture Sensitivity Level	MSL 3	



Caution! ESD sensitive device.

Exceeding any one or a combination of the Absolute Maximum Rating conditions may cause permanent damage to the device. Extended application of Absolute Maximum Rating conditions to the device may reduce device reliability. Specified typical performance or functional operation of the device under Absolute Maximum Rating conditions is not implied.

The information in this publication is believed to be accurate and reliable. However, no responsibility is assumed by RF Micro Devices, Inc. ("RFMD") for its use, nor for any infringement of patents, or other rights of third parties, resulting from its use. No license is granted by implication or otherwise under any patent or patent rights of RFMD. RFMD reserves the right to change component circuitry, recommended application circuitry and specifications at any time without prior notice.



RFMD Green: RoHS compliant per EU Directive 2002/95/EC, halogen free per IEC 61249-2-21, < 1000ppm each of antimony trioxide in polymeric materials and red phosphorus as a flame retardant, and <2% antimony in solder.

Nominal Operating Parameters

Parameter	Specification			Unit	Condition
	Min.	Typ.	Max.		
Overall					Temp = 25 °C, V _{CC} = V _{DD} = 5V, standard application circuit
Frequency Range	300		1100	MHz	
Max Gain		36		dB	Attenuation = 0dB, at 450MHz
Gain Control Range		31.5		dB	
Step Accuracy	±(0.15 +5% attenuation setting)			dB	Major state error up to 1100MHz
P1dB		25		dBm	Attenuation = 0dB, at 450MHz
Output IP3		44		dBm	P _{OUT} = 5dBm/Tone, 1MHz spacing at 450MHz
Control Interface		6		bit	SPI Interface
Settling Time		250		ns	t _{ON} , t _{OFF} (10%/90% RF)
Noise Figure		4.2		dB	Attenuation = 0dB
Impedance		50		Ω	
Input Return Loss		18		dB	At 450MHz
Output Return Loss		14.9		dB	
Total Supply Voltage	4.75	5.0	5.25	V	
Supply Current	207	215	245	mA	From V _{CC} (SPI), V _{CC} (AMP1), and V _{CC} (AMP2)
Thermal Resistance		73		°C/W	

Typical RF Performance at Key Operating Frequencies

Parameter	Unit	350MHz	450MHz	550MHz	700MHz	850MHz	900MHz	950MHz	1050MHz
Max Small Signal Gain	dB	37.1	36.8	36.3	35.2	34.1	33.7	33.3	32.6
Output P1dB	dBm	25.1	25	24.3	24.5	24.3	24.4	24.5	24.4
Output IP3*	dBm	44.2	44.1	41.4	41.3	41.6	41.6	41.9	42
Input Return Loss	dB	22.3	18	16	14.9	16	17.1	17.9	18.3
Output Return Loss	dB	9.8	14.4	27	17.8	14.2	14.3	15	17.2

*Note: OIP3 is tested at P_{OUT} = 5dBm/Tone and 1MHz spacing

Typical Performance - 300MHz to 1100MHz Broadband Application Circuit

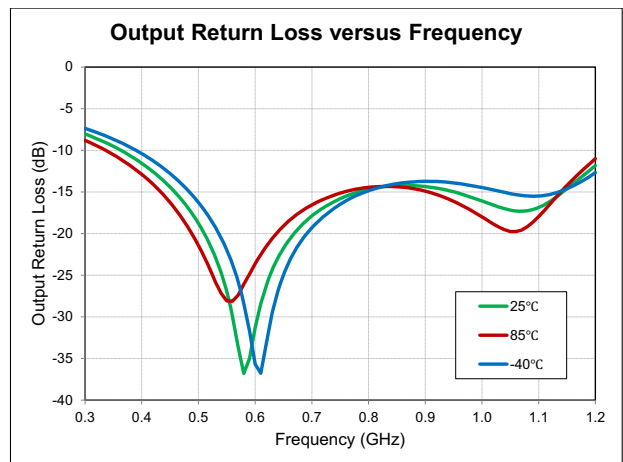
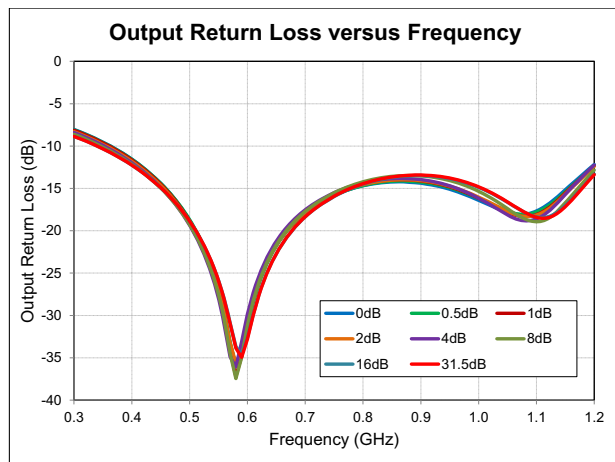
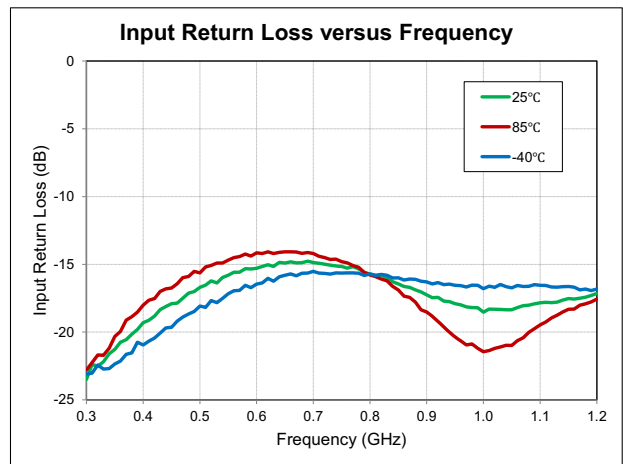
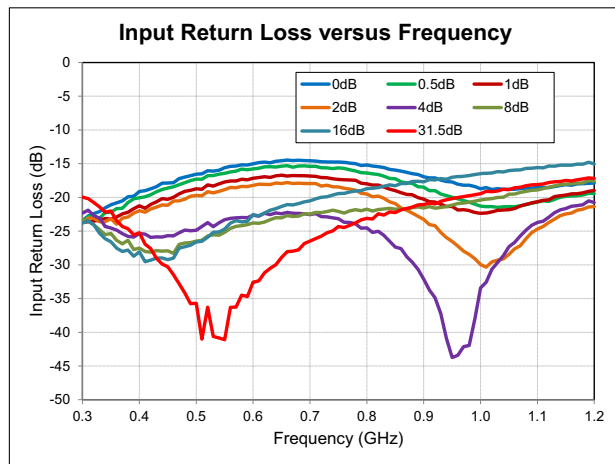
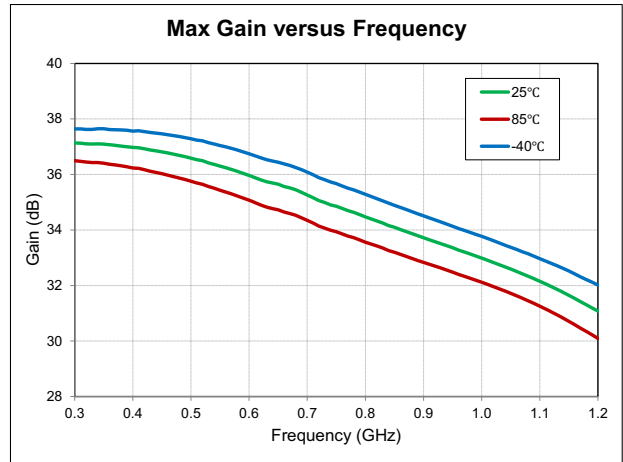
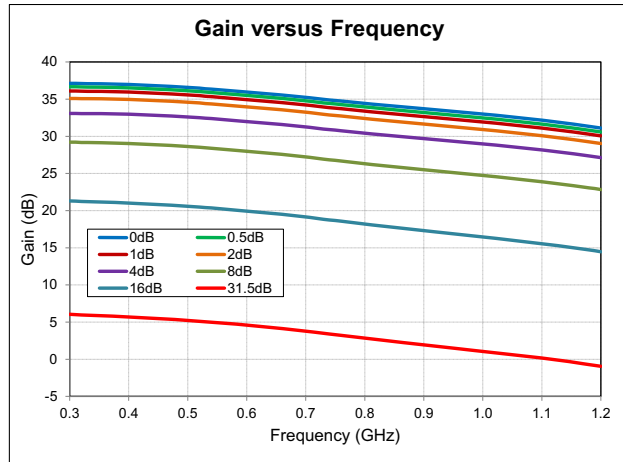

Typical Performance - 300MHz to 1100MHz Broadband Application Circuit

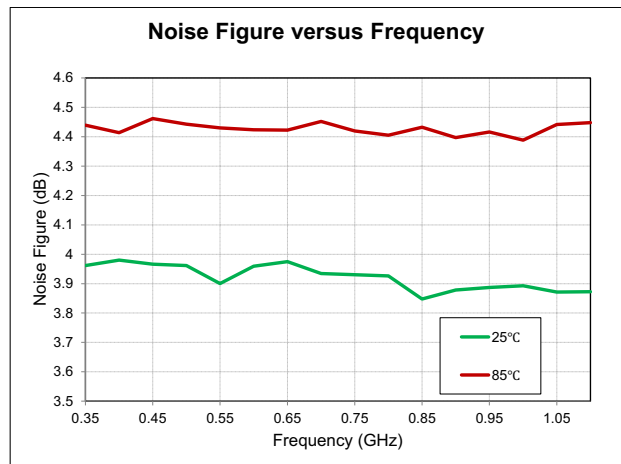
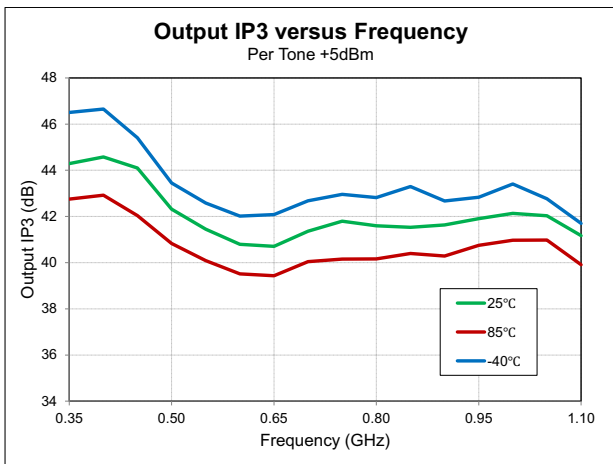
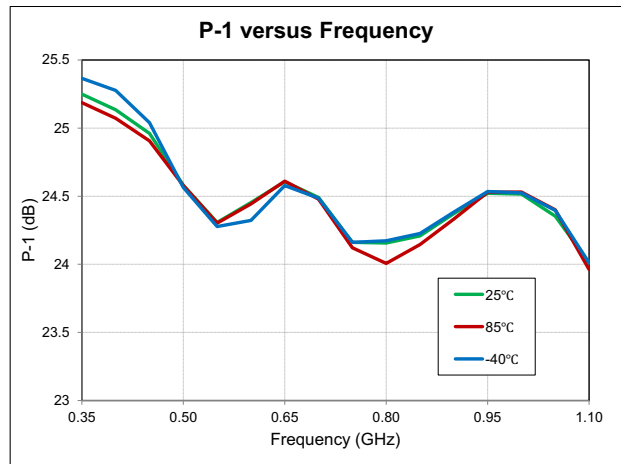
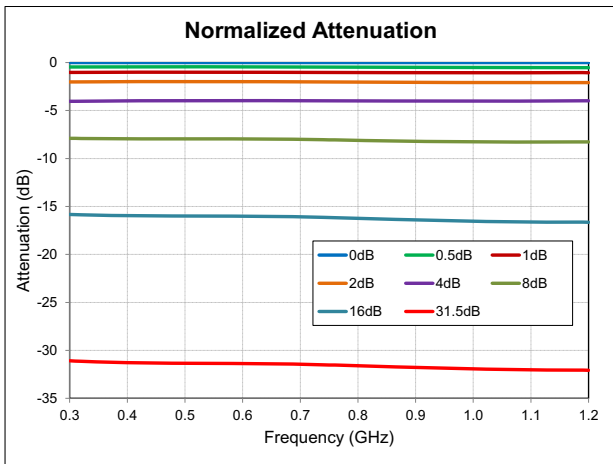
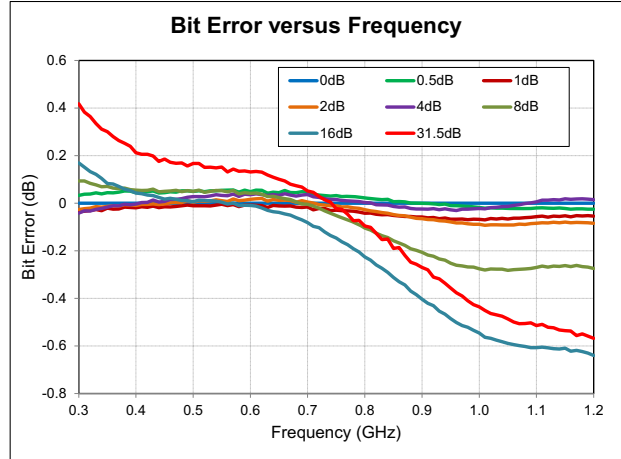
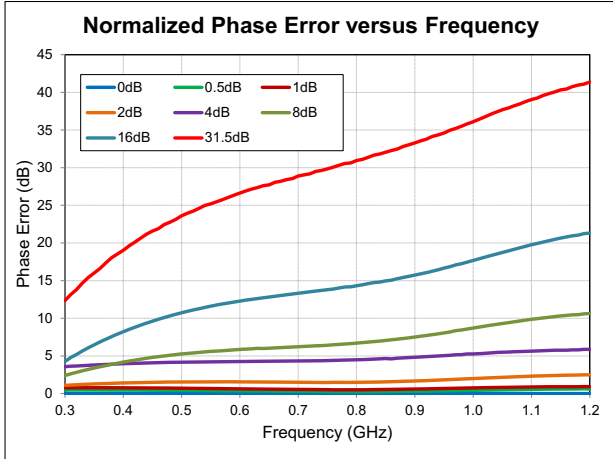

Truth Table

Control Bit						Gain Relative to Max Gain
D5	D4	D3	D2	D1	D0	
1	1	1	1	1	1	0dB
1	1	1	1	1	0	-0.5dB
1	1	1	1	0	1	-1dB
1	1	1	0	1	1	-2dB
1	1	0	1	1	1	-4dB
1	0	1	1	1	1	-8dB
0	1	1	1	1	1	-16dB
0	0	0	0	0	0	-31.5dB

**Serial Port Interface:
SPI Timing Diagram**

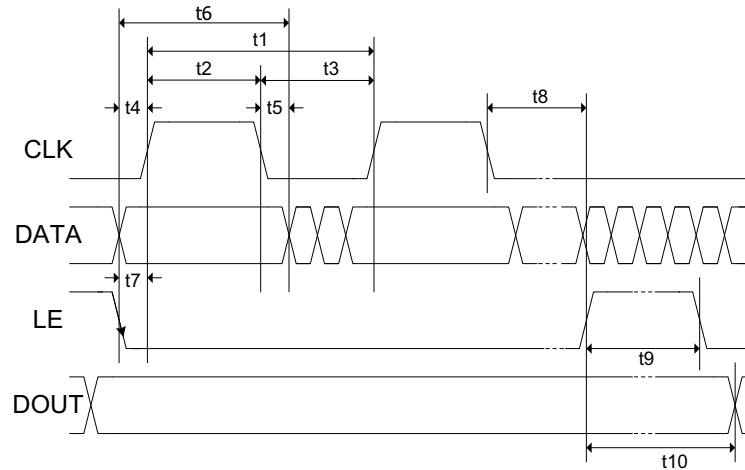

SPI Timing Diagram Specifications

Parameter	Limit	Unit	Comment
t1	25	MHz max	CLK Frequency
t2	20	ns min	CLK High
t3	20	ns min	CLK Low
t4	5	ns min	DATA to CLK Setup Time
t5	5	ns min	DATA to CLK Hold Time
t6	30	ns min	DATA Valid
t7	5	ns min	LE to CLK Setup Time
t8	5	ns min	CLK to LE Setup Time
t9	10	ns min	LE Pulse Width
t10	20	ns max	Output Set

Programming Example - 6-Bit

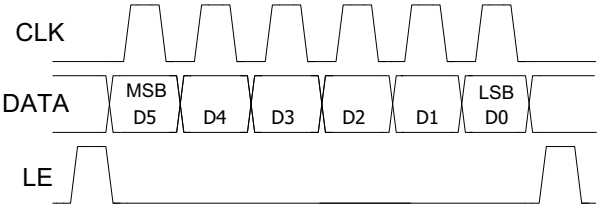

Control Voltage Table	
State	Logic
Low	0V to 0.8V
High	2.0V to 5.0V

Power-up Programming Truth Table	
PUP	Attenuator Setting
Low	Attenuation at Max, 31.5 dB
High	Attenuation at Min, 0 dB

Pin Names and Description

Pin	Function	Description
1	SPI_LE	Serial Latch Enable Input
2	SPI_DATA	Serial Data Input
3	SPI_CLK	Serial Clock Input
4	PUP	Power-up Programming Pin
5	GND	RF/DC Ground Connection
6	RF_IN	RF Input
7	GND	RF/DC Ground Connection
8	VCC_AMP1	Supply Voltage for Amplifier 1
9	GND	RF/DC Ground Connection
10	GND	RF/DC Ground Connection
11	GND	RF/DC Ground Connection
12	GND	RF/DC Ground Connection
13	GND	RF/DC Ground Connection
14	VCC_AMP2	Supply Voltage for Amplifier 2
15	GND	RF/DC Ground Connection
16	RF_OUT	RF Output
17	GND	RF/DC Ground Connection
18	GND	RF/DC Ground Connection
19	GND	RF/DC Ground Connection
20	GND	RF/DC Ground Connection
21	GND	RF/DC Ground Connection
22	NC	Do Not Connect, Leave Open Circuit
23	GND	RF/DC Ground Connection
24	GND	RF/DC Ground Connection
25	GND	RF/DC Ground Connection
26	GND	RF/DC Ground Connection
27	GND	RF/DC Ground Connection
28	VCC_SPI	Supply Voltage for SPI and DSA Chip

Package Drawing: 6.0mm x 6.0mm Laminate Module

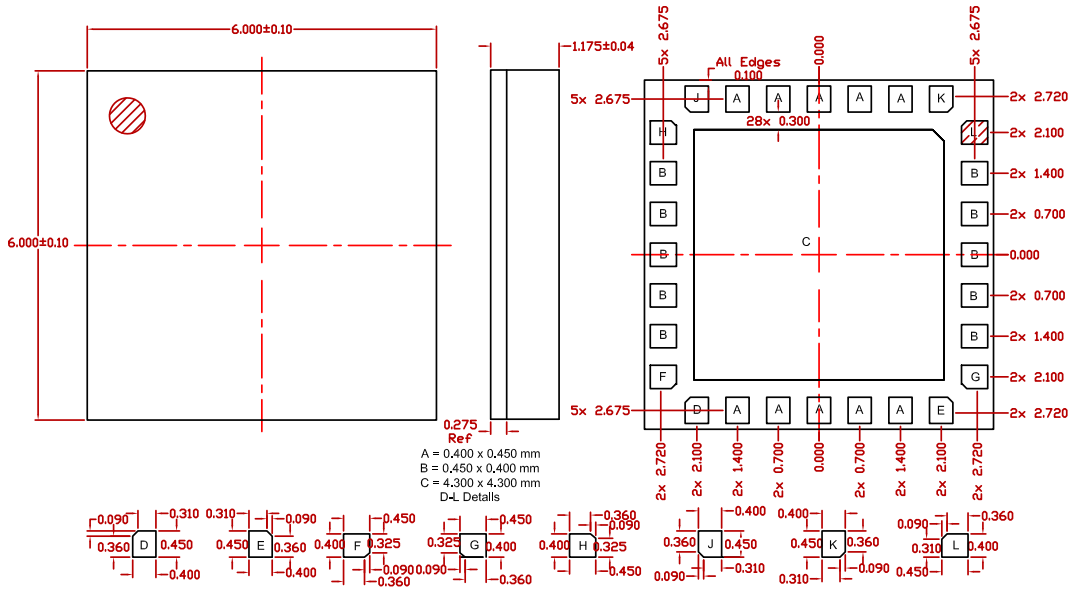

Evaluation Board Assembly Drawing

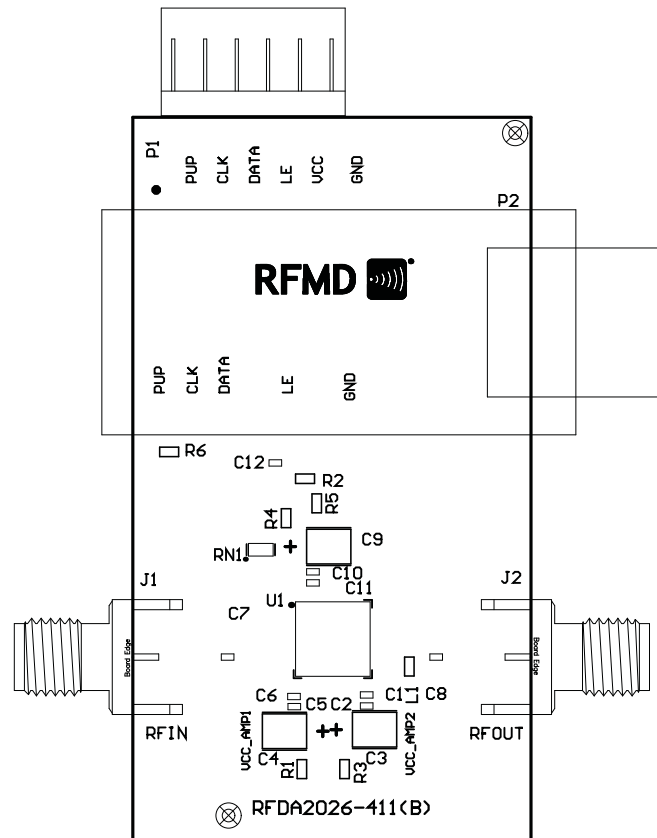

Evaluation Board Schematic 300MHz to 1100MHz Application Circuit

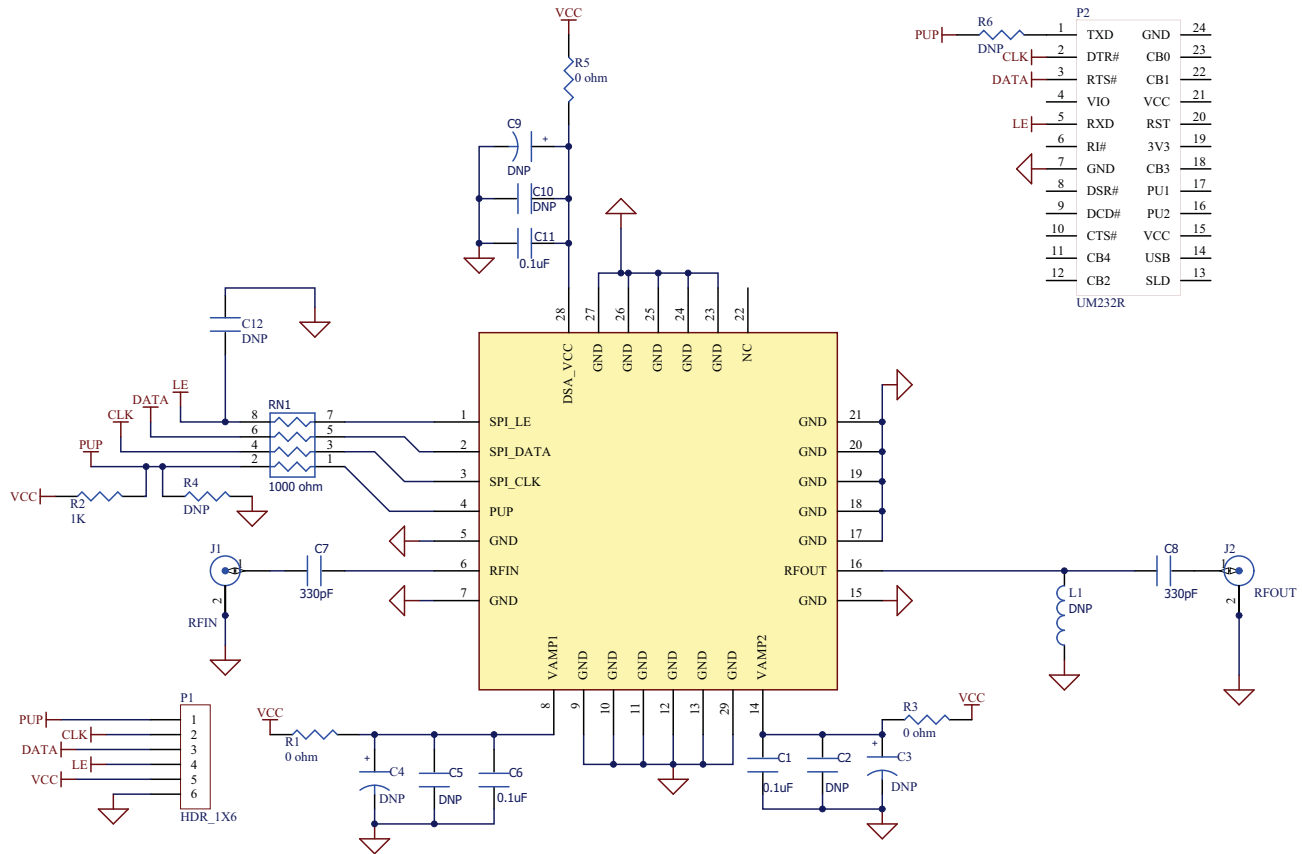

Evaluation Board Bill of Materials (BOM) 300MHz to 1100MHz Application Circuit

Description	Reference Designator	Manufacturer	Manufacturer's P/N
RFDA0056, 6 x 6sq.mm, 28-Pin Laminate	U1	RFMD	RFDA0056
RFDA2026-411(B)		Viasystems	RFDA2026-411(B)
CONN, SMA, END LNCH, FLT, 0.062"	J1-J2	Emerson Network Power	142-0701-821
CAP, 0.1µF, 10%, 10V, X7R, 0402	C1, C6, C11	Murata Electronics	GRM155R71C104KA88D
CAP, 330pF, 10%, 50V, X7R, 0402	C7-C8	Murata Electronics	GRM155R71H331KA01E
RES, 1K, 5%, 1/16W, 0603	R2	Panasonic Industrial Co.	ERJ-3GEYJ102
RES ARRAY, 4-ELEM, 1K, 5%, SMD 4 X 00402	RN1	KOA	CN1E4KTTD102J
CONN, HDR, ST, PLRZD, 6-PIN, 0.100"	P1	ITW Pancon	MPSS100-6-C
CONN, SKT, 24-PIN DIP, .600", T/H	P2	Aries Electronics Inc.	24-6518-10
RES, 0Ω, 0603	R1, R3, R5	Kamaya, Inc	RMC1/16JPTP
DNP	C2-C5, C9-C10, R4, L1	N/A	N/A

Branding Diagram

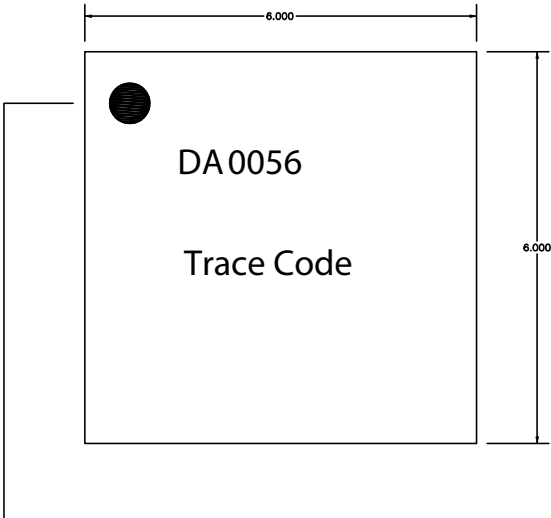

Pin 1 Indicator

Trace Code to be assigned by SubCon