

2

1

REVISION HISTORY			
REV	AUTH	DATE	DESCRIPTION
A	-	2/11/2009	INITIAL RELEASE

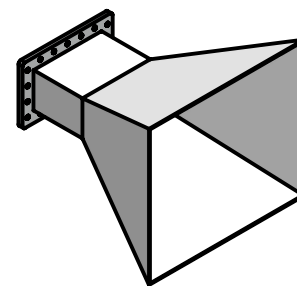
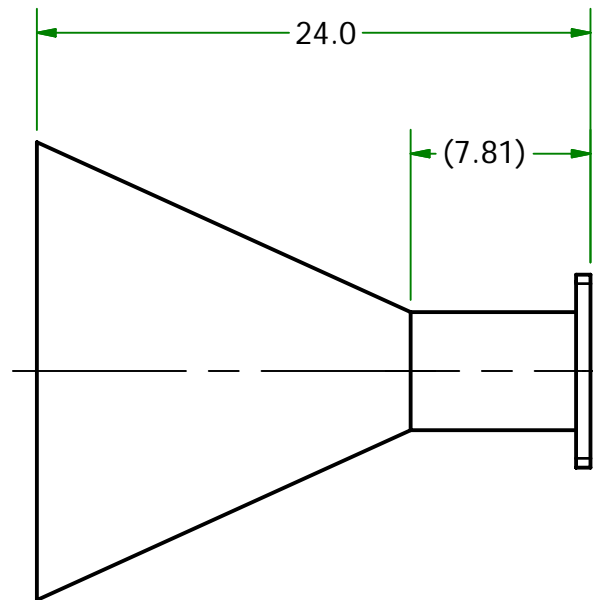
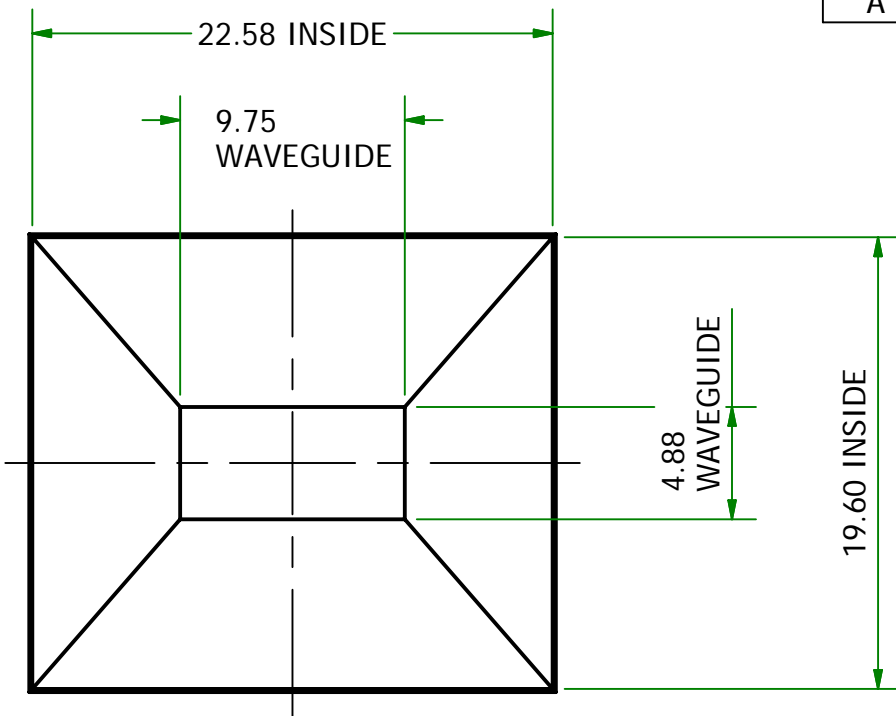

MODEL NO.	975-441-2
WG SIZE:	WR975
FREQUENCY RANGE:	0.75-1.12 GHz
GAIN:	14 dB
APERATURE:	22.58 X 19.60
FLANGE:	AS ORDERED

THIRD ANGLE PROJECTION:		APPROVALS	DATE	ADVANCED TECHNICAL MATERIALS, INC. TEL: (631) 289-0363 FAX: (631) 289-0358 www.atmmicrowave.com	<small>THE INFORMATION IN THIS DRAWING IS PROPRIETARY AND SHALL NOT BE USED OR DISCLOSED WITHOUT THE PRIOR WRITTEN CONSENT OF ATM, INC. DO NOT SCALE DWG.</small>
UNLESS OTHERWISE NOTED, DIMENSIONS ARE IN INCHES, TOLERANCES ARE: FRACTIONS: ±1/64 ANGLES: ±1/2°		DRAWN BF	2-11-09		
BASIC DIMENSION		DECIMALS		OUTLINE, HORN ANTENNA WR975	
		2 PLACE	3 PLACE		
UNDER 6"	±.02	±.005			
6" - 12"	±.03	±.010		MATERIAL ALUMINUM	SIZE A
OVER 12"	±.06	±.015		TREATMENT IRIDITE	CAGE CODE 0R8N4
				FINISH ATM STD GRAY	ATM DWG # 9600
				MODEL # 975-441-2	REVISION A
					SHEET 1 OF 1

2

1