



# CMD232

## 2-9 GHz Driver Amplifier

### Features

- ▶ High gain
- ▶ Wide bandwidth
- ▶ Single positive supply voltage
- ▶ Small die size

### Description

The CMD232 is a wideband GaAs MMIC driver amplifier ideally suited for military, space and communications systems where small size and high linearity are needed. At 6 GHz the device delivers greater than 15 dB of gain with a corresponding output 1 dB compression point of +17 dBm and an output IP3 of 23 dBm. The CMD232 is a 50 ohm matched design which eliminates the need for external DC blocks and RF port matching. The CMD232 offers full passivation for increased reliability and moisture protection.

### Applications

- ▶ Point-to-point radios
- ▶ Point-to-multi-point radios
- ▶ Military and space
- ▶ Test Instrumentation
- ▶ CMM-9 replacement

### Functional Block Diagram

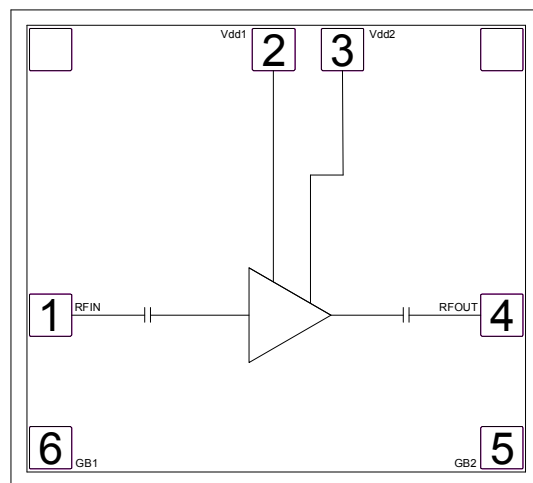

### Electrical Performance - $V_{dd} = 6.0 \text{ V}$ , $T_A = 25 \text{ }^\circ\text{C}$ , $F=6 \text{ GHz}$

Parameter	Min	Typ	Max	Units
Frequency Range	2 - 9			GHz
Gain		15		dB
Input Return Loss		15		dB
Output Return Loss		14		dB
Output P1dB		17		dBm
Output IP3		23		dBm
Supply Current		90		mA

ver 1.0 0116

### Specifications

#### Absolute Maximum Ratings

Parameter	Rating
Drain Voltage, V <sub>dd</sub>	7.5 V
RF Input Power	+15 dBm
Channel Temperature, T <sub>ch</sub>	150 °C
Power Dissipation, P <sub>diss</sub>	665 mW
Thermal Resistance	97.5 °C/W
Operating Temperature	-55 to 85 °C
Storage Temperature	-55 to 150 °C

Operation of this device outside the maximum ratings may cause permanent damage.

#### Recommended Operating Conditions

Parameter	Min	Typ	Max	Units
V <sub>dd</sub>	5.0	6.0	7.0	V
I <sub>dd</sub>		90		mA

Electrical performance is measured at specific test conditions. Electrical specifications are not guaranteed over all recommended operating conditions.

#### Electrical Specifications, V<sub>dd</sub> = 6.0 V, T<sub>A</sub> = 25 °C

Parameter	Min	Typ	Max	Units
Frequency Range	2 - 9			GHz
Gain	12	15	19	dB
Noise Figure		4.5		dB
Input Return Loss		15		dB
Output Return Loss		13		dB
Output P1dB	15	17		dBm
Output IP3		23.5		dBm
Supply Current	60	90	120	mA
Gain Temperature Coefficient		0.014		dB/°C
Noise Figure Temperature Coefficient		0.012		dB/°C

ver 1.0 0116

### Typical Performance

Broadband Performance,  $V_{dd} = 6.0\text{ V}$ ,  $I_{dd} = 90\text{ mA}$ ,  $T_A = 25\text{ }^\circ\text{C}$

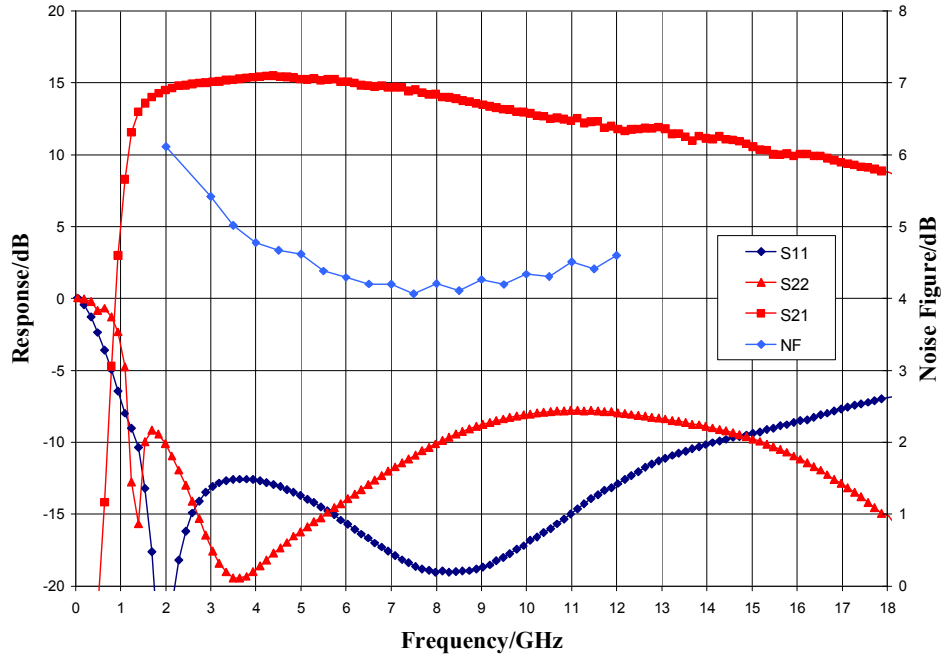

Narrow-band Performance,  $V_{dd} = 6.0\text{ V}$ ,  $I_{dd} = 90\text{ mA}$ ,  $T_A = 25\text{ }^\circ\text{C}$

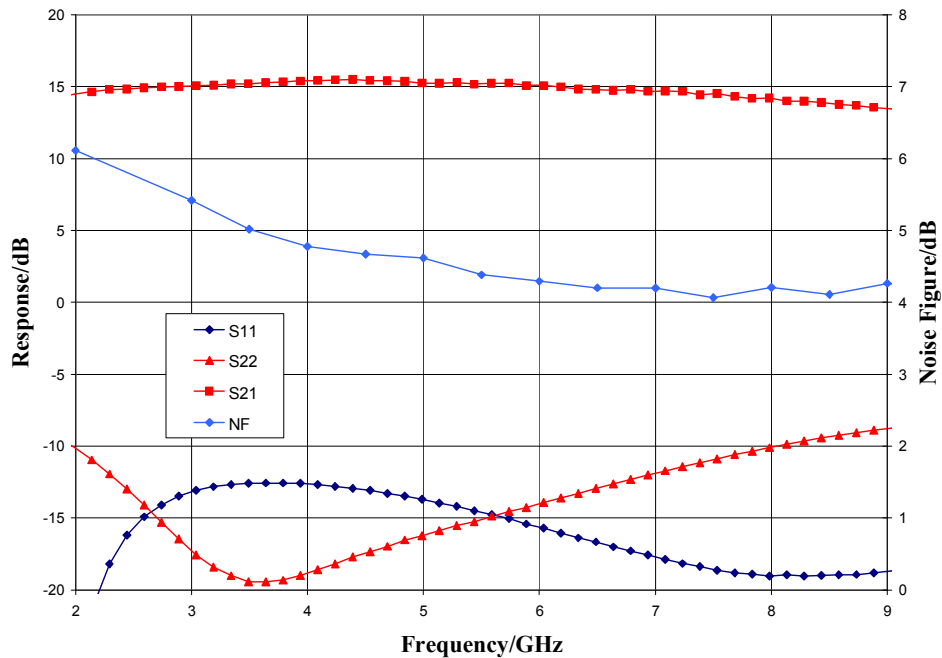

ver 1.0 0116

### Typical Performance

Gain vs. Temperature,  $V_{dd} = 6.0\text{ V}$

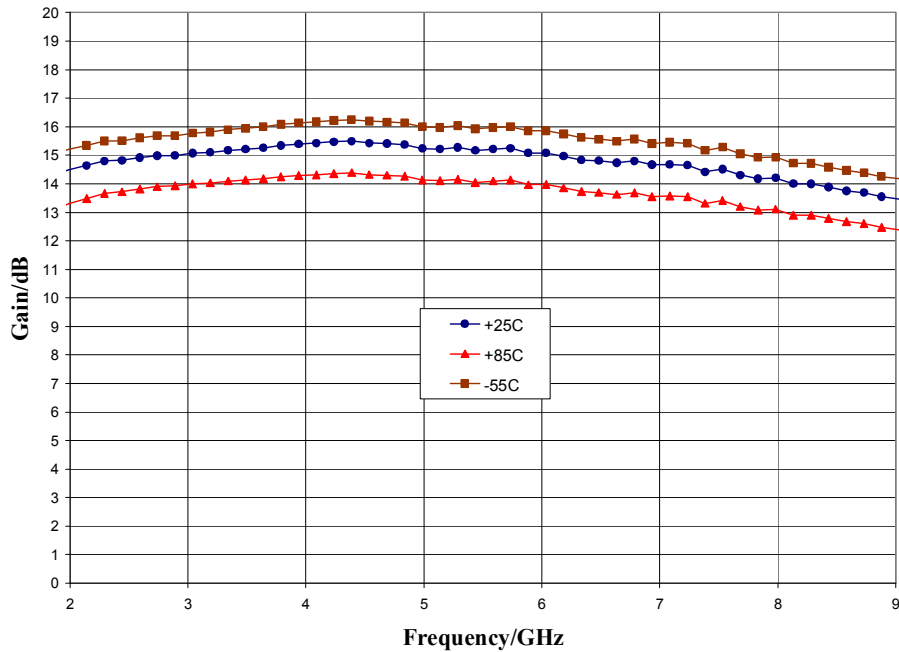

Gain vs. Supply Voltage,  $T_A = 25\text{ }^\circ\text{C}$

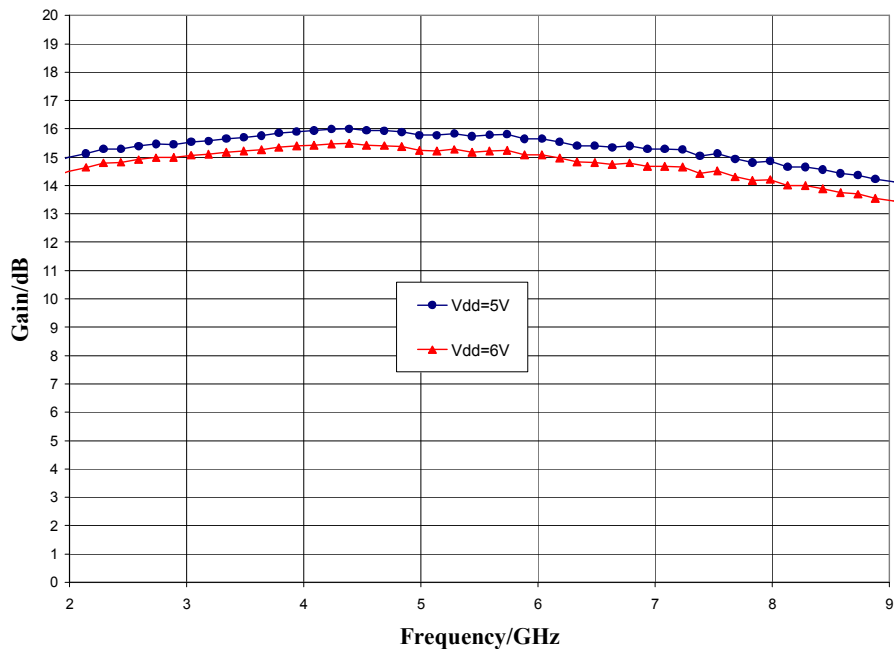

ver 1.0 0116

### Typical Performance

Noise Figure vs. Temperature,  $V_{dd} = 6.0\text{ V}$

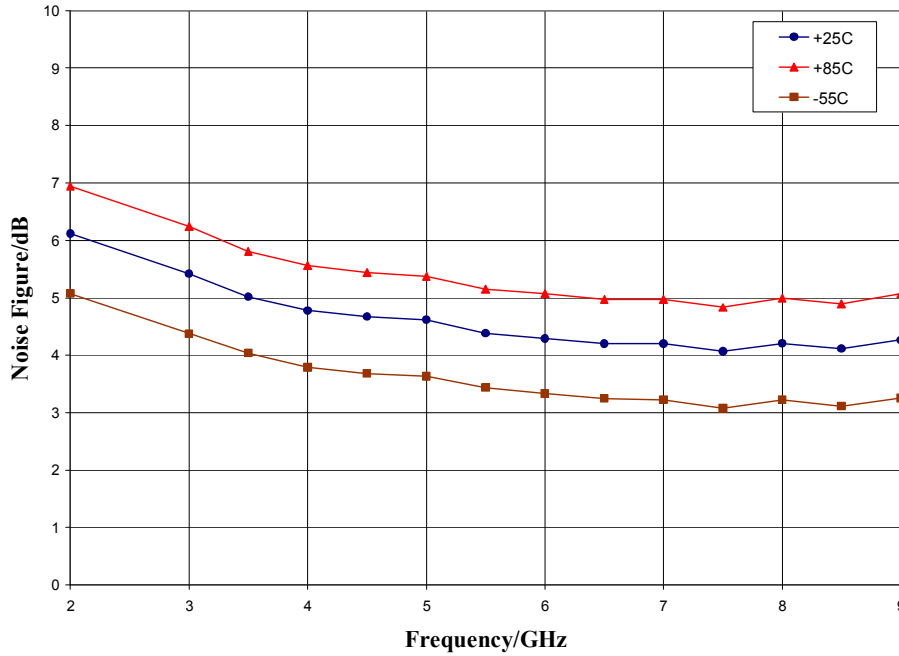

Noise Figure vs. Supply Voltage,  $T_A = 25\text{ }^\circ\text{C}$

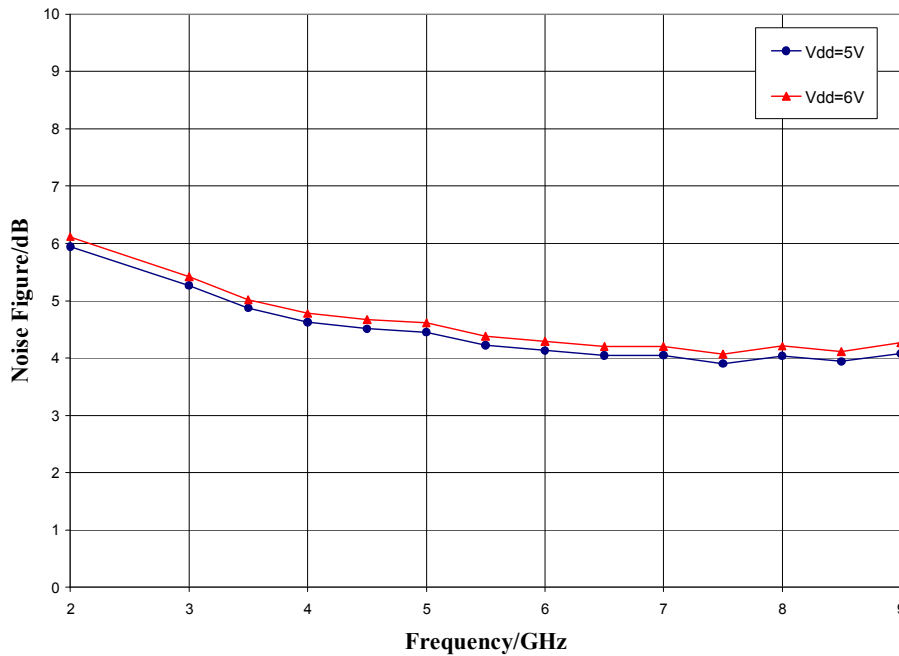

ver 1.0 0116

### Typical Performance

**P1dB vs. Temperature,  $V_{dd} = 6.0\text{ V}$**

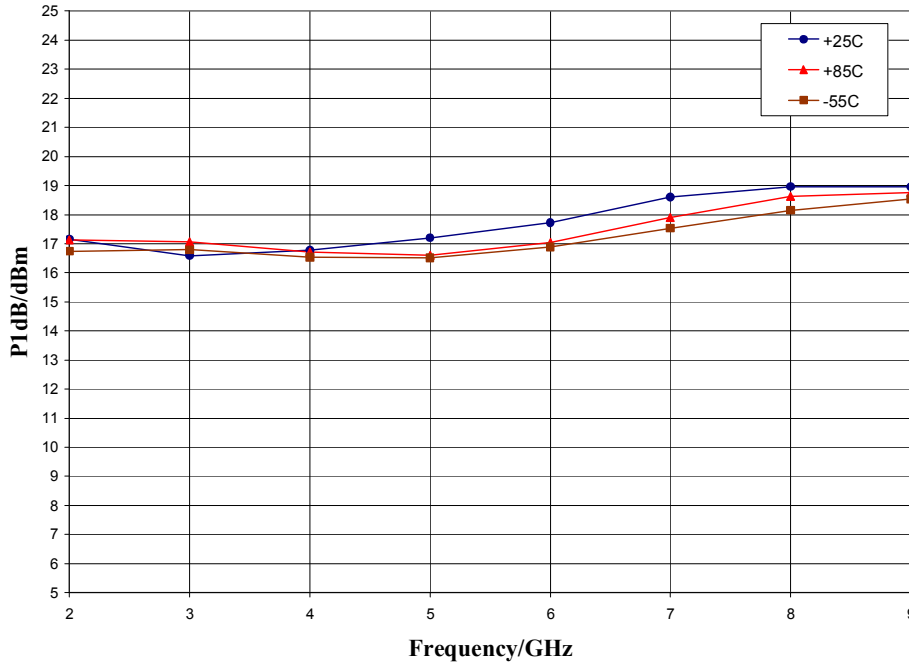

**P1dB vs. Supply Voltage,  $T_A = 25\text{ }^\circ\text{C}$**

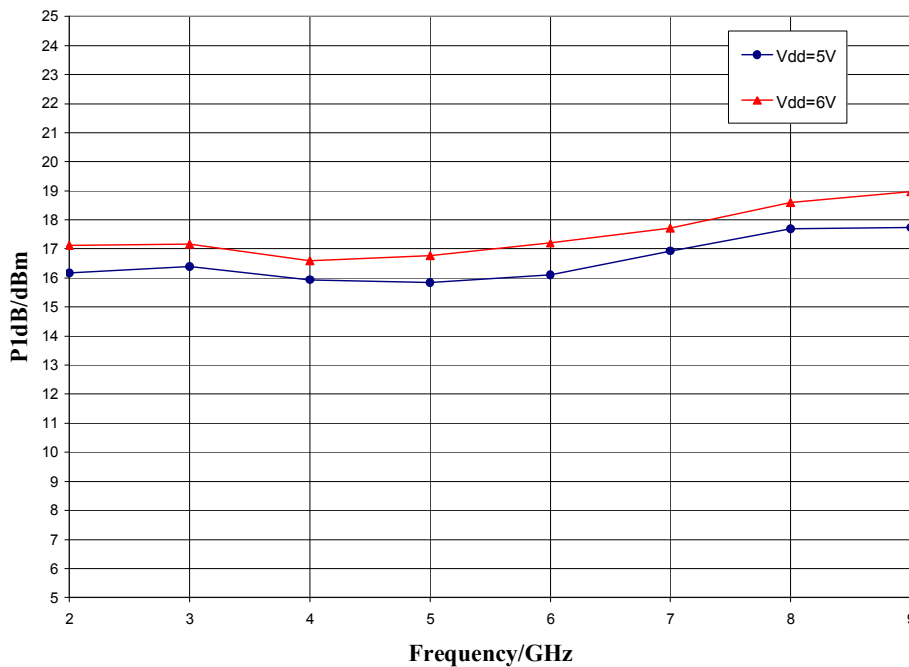

ver 1.0 0116

### Typical Performance

**Output IP3 vs. Temperature,  $V_{dd} = 6.0\text{ V}$**

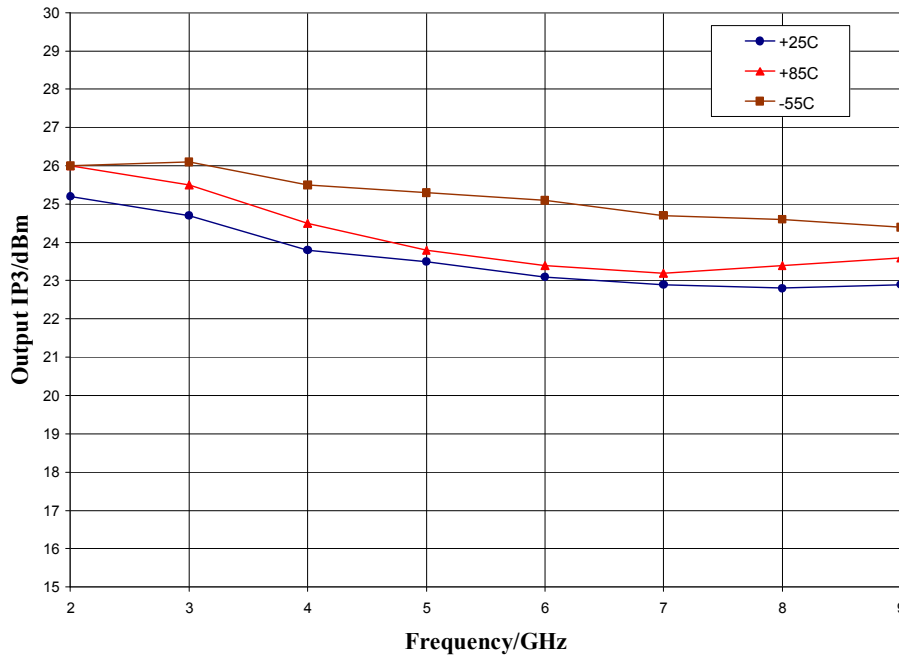

**Output IP3 vs. Supply Voltage,  $T_A = 25\text{ }^\circ\text{C}$**

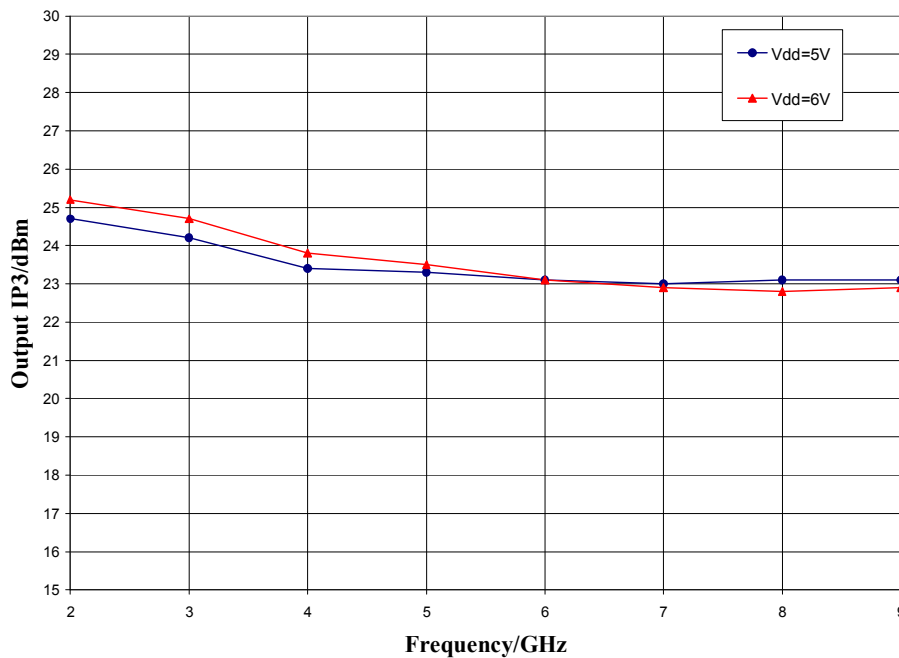

ver 1.0 0116

### Typical Performance

Output Power,  $V_{dd} = 6.0\text{ V}$ ,  $T_A = 25\text{ }^\circ\text{C}$

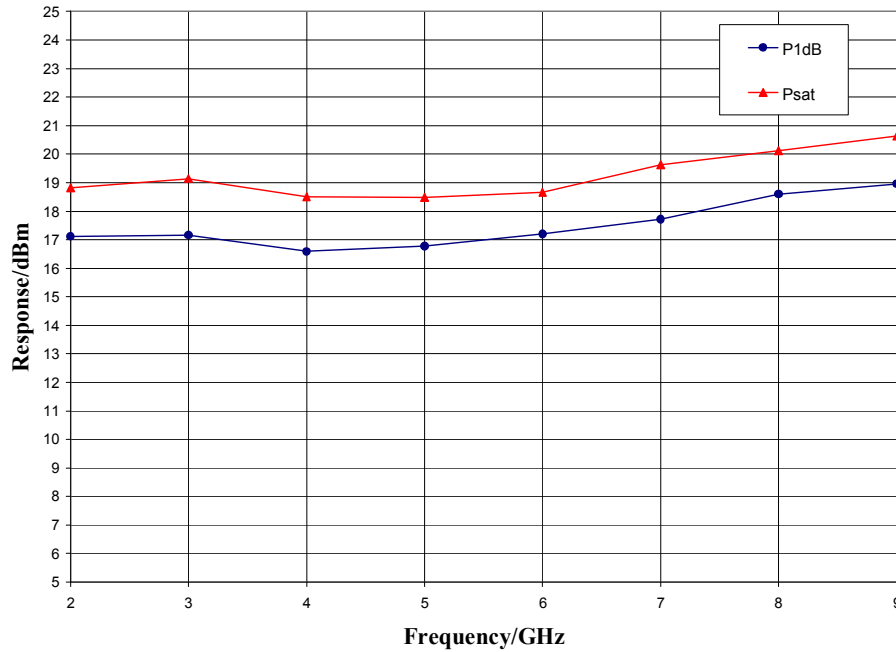



### Mechanical Information

#### Die Outline (all dimensions in microns)

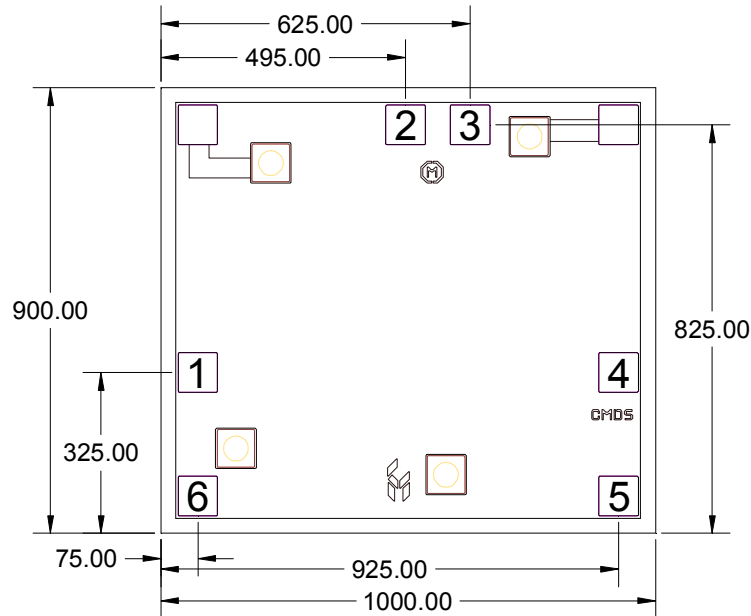

#### Notes:



1. No connection required for unlabeled pads
2. Backside is RF and DC ground
3. Backside and bond pad metal: Gold
4. Die is 100 microns thick
5. Bond pads are 80 microns square

### Pad Description

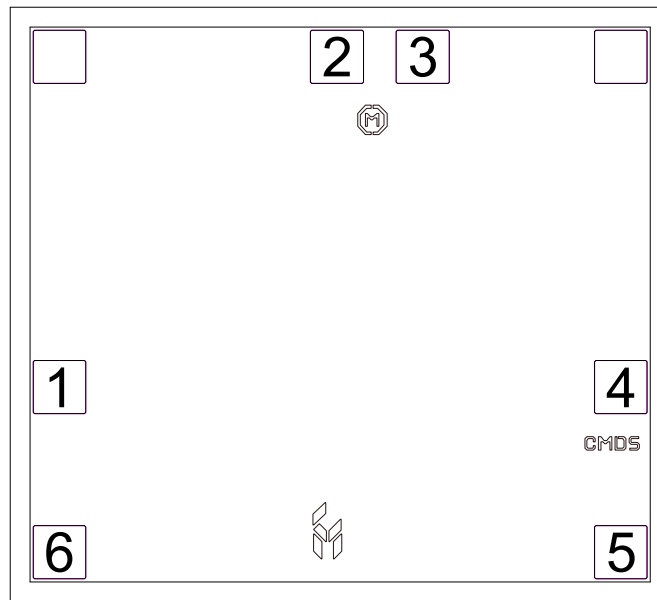
### Pad Diagram

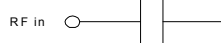
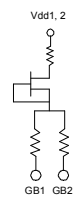

### Functional Description

Pad	Function	Description	Schematic
1	RF in	DC blocked and 50 ohm matched	
2,3	Vdd1, 2	Power supply voltage Decoupling and bypass caps required	
5, 6	GB2, 1	Connect to DC ground	
4	RF out	DC blocked and 50 ohm matched	
Backside	Ground	Connect to RF / DC ground	

### Applications Information

#### Assembly Guidelines

The backside of the CMD232 is RF ground. Die attach may be accomplished with either electrically and thermally conductive epoxy or eutectic attach. Standard assembly procedures should be followed for high frequency devices. The top surface of the semiconductor should be made planar to the adjacent RF transmission lines, and the RF decoupling capacitors should be placed as close as possible to the DC connections on chip.

RF connections should be made as short as possible to reduce the inductive effect of the bond wire. Use of a 0.8 mil thermosonic wedge bonding is highly recommended as the loop height will be minimized. The RF input and output require a single bond wire as shown.

The semiconductor is 100 um thick and should be handled by the sides of the die or with a custom collet. Do not make contact directly with the die surface as this will damage the monolithic circuitry. Handle with care.

#### Assembly Diagram

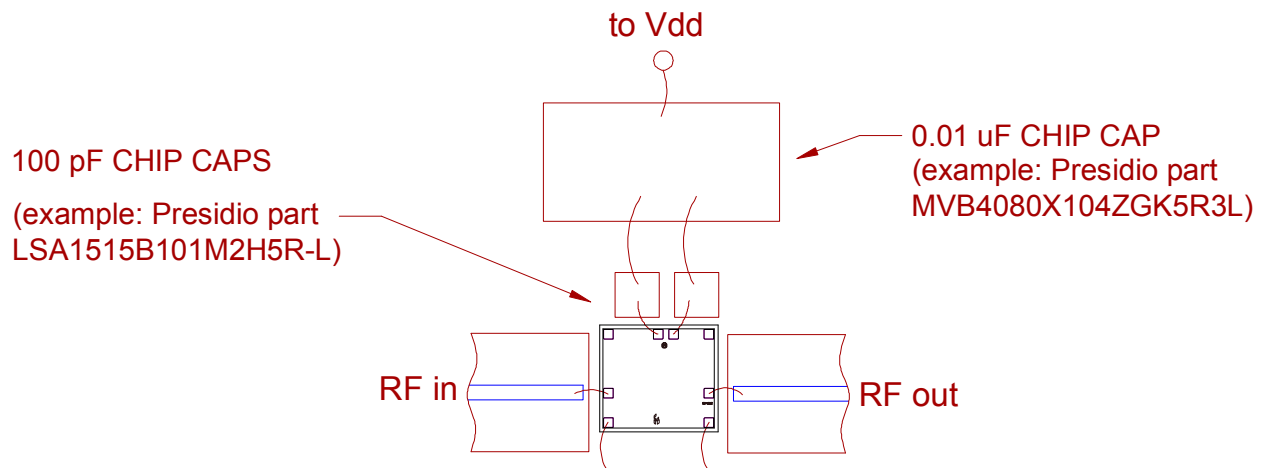

**GaAs MMIC devices are susceptible to damage from Electrostatic Discharge. Proper precautions should be observed during handling, assembly and test.**

ver 1.0 0116

---

*Applications Information***Biasing and Operation**

The CMD232 is biased with a single positive drain supply. Performance is optimized when the drain voltage is set between +5.0 V and +6.0 V.

Turn ON procedure:

1. Apply drain voltage  $V_{dd}$  and set to +6 V

Turn OFF procedure:

1. Turn off drain voltage  $V_{dd}$

RF power can be applied at any time.