

REV A	AUTH J.L.E.	DATE 5/28/03	INITIAL RELEASE
REV B	AUTH J.L.E.	DATE 6/16/03	CONNECTOR MOVED, ADAPTER LENGTH REDUCED. LENGTH 36.00 MAX WAS 36.43
REV C	AUTH M.R.	DATE 10/9/09	MOUNT UPDATED, LENGTH 36.40 WAS 36 MAX, FORMAT UPDATED.
REV D	AUTH M.R.	DATE 12/11/09	MOUNT LOCATION CORRECTED, WAS 13.42.

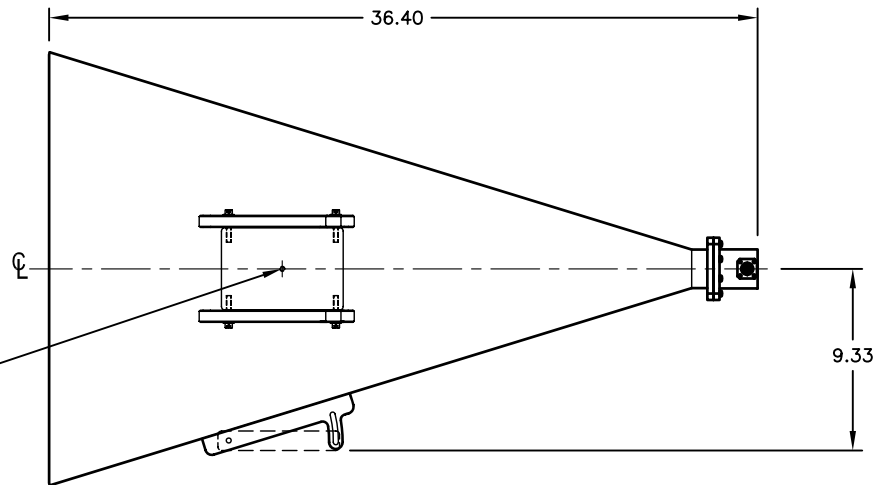
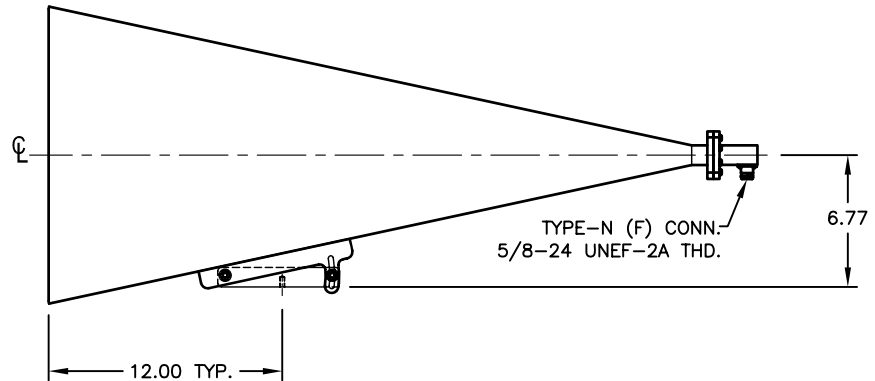
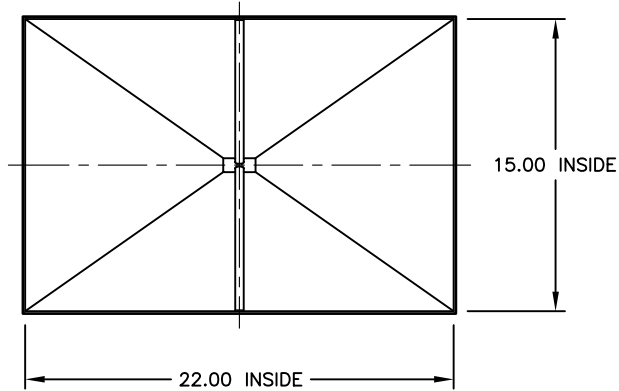

1/4-20 x 1 PLC.
(1 MOUNTING BLOCK PER ASSY.)

MODEL SPECIFICATIONS

MECHANICAL

MODEL NUMBER: 250-442EM-NF
 MATERIAL: 6061/T-6 ALUM.
 FINISH: UNIQUE CORROSION RESISTANT
 316 STAINLESS STEEL EPOXY COATING

ELECTRICAL

FREQ. RANGE: 2.5 - 8.0 GHz
 GAIN: 18-20 dB (LOW TO HIGH FREQ.)
 VSWR: 1.60 MAX.

THIRD ANGLE PROJECTION:		APPROVALS	DATE	ADVANCED TECHNICAL MATERIALS, INC. TEL: (631) 289-0363 FAX: (631) 289-0358 www.atmmicrowave.com		<small>THE INFORMATION IN THIS DRAWING IS PROPRIETARY AND SHALL NOT BE USED OR DISCLOSED WITHOUT THE PRIOR WRITTEN CONSENT OF ATM, INC. DO NOT SCALE DWG.</small>			
UNLESS OTHERWISE NOTED, DIMENSIONS ARE IN INCHES, TOLERANCES ARE: FRACTIONS: ±1/64 ANGLES: ±1/2°		DRAWN J.L.E.	5/28/03						
BASIC DIMENSION	DECIMALS 2 PLACE 3 PLACE	CHKD.	APRVD.	OUTLINE, WRD250 HORN ANTENNA		SIZE A	CAGE CODE 0R8N4	ATM DWG # 5664	REVISION D
UNDER 6"	±.02 ±.005	MATERIAL ALUM.				SCALE NONE	MODEL # 250-442EM-NF	SHEET 1/1	
6" - 12"	±.03 ±.010	TREATMENT IRIDITE							
OVER 12"	±.06 ±.015	FINISH ATM STD. GRAY							