

Applications

- IEEE802.11a/b/g/n WLAN / BT Applications
- Single-Chip RF Front-End Module (FEM)
- Wireless LAN Systems
- Portable Battery-Powered Equipment

Product Features

- Fully Integrated, 802.11a/b/g/n + BT FEM
- Internally Matched Input / Output
- Integrated Directional Detectors
- Temperature Compensated Bias Network
- Single Battery Voltage Of +2.3 V – +4.8 V
- Leadless 4.0 x 4.0 x 0.5 mm SMT Pb-Free
- Minimum Pout = +20.5 dBm, 802.11b
- Minimum Pout = +15.5 dBm, 802.11g (OFDM 64 QAM At 3.8 % EVM)
- Minimum Pout = +15.0 dBm, 802.11a (OFDM 64 QAM At 3.5 % EVM)
- 4.0 x 4.0 x 0.5 mm ETSLP-24 Package
- Lead-free, RoHS-compliant, MSL-1

General Description

The TQP6M9002 is a full WLAN/BT front-end module (FEM) in an ultra small 4 mm x 4 mm footprint package for 802.11a/b/g/n and Bluetooth applications. Integratd into this FEM are a 2.4 GHz PA, 5 GHz PA, directional detectors, front-end switch, Bluetooth path, and receive baluns. The architecture and interface are optimized for next generation WLAN integration into handset devices. This front-end module features CMOS compatible control voltages to facilitate ease of use.

The TQP6M9002 is manufactured in TriQuint's high-reliability E/D pHEMT technology and is assembled in thin profile 4 mm x 4 mm x 0.5 mm ETSLP-24 Pb-Free package

Functional Block Diagram

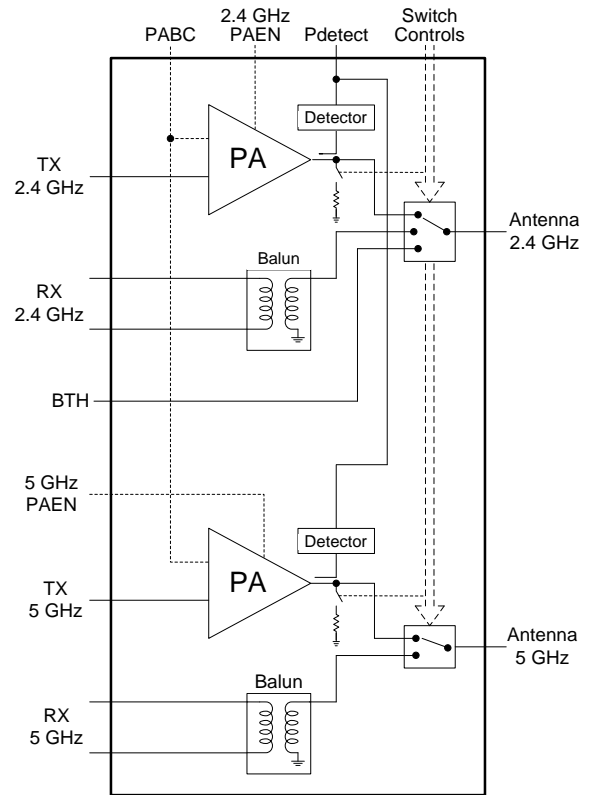

Electrical Specifications

Parameter	Min	Typ	Max	Units
Frequency	2400		2500	MHz
P _{OUT} , 802.11g, 64 QAM, 3.8% EVM	+15.5	+17		dBm
Current, 802.11g, Pout= +15.5 dBm		120		mA
Frequency	4900		5850	MHz
P _{OUT} , 802.11a, 64 QAM, 3.5% EVM	+15	+17		dBm
Current, 802.11a, Pout= +15.0 dBm		150		mA

Ordering Information

Part No.	Description
TQP6M9002	802.11a/b/g/n WLAN/BT FEM

Standard T/R size = 2500 pieces on a 13" reel