

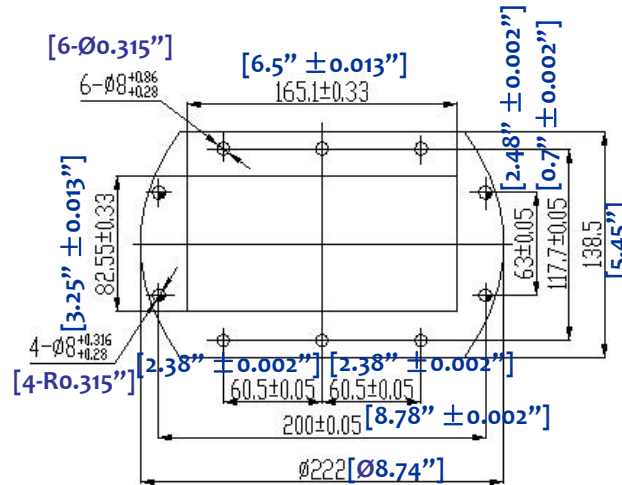

# WR650 WAVEGUIDE 500W HIGH POWER TERMINATION - RFWT650A

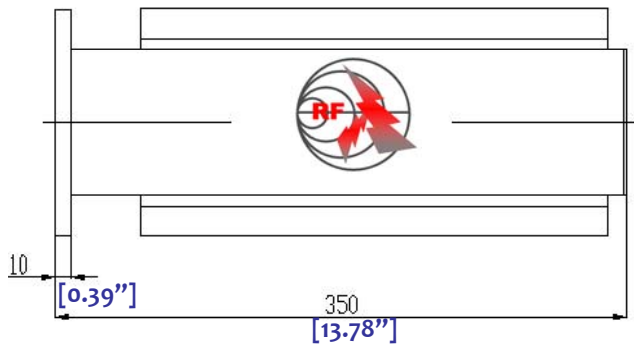

1.0 Mechanical Specifications		
1.1	Waveguide type	Rectangular Waveguide WR650
1.2	Flange type	CPRF, COVER
1.3	Flange Holes	Through
1.4	Basis-material	Alloyed Cuprum
1.5	Internal Body Finish	Silver Plated chromate or conversion
1.6	External Body Finish	Body painted with gray/black epoxy enamel

2.0 Environment specifications		
2.1	Operation Temp.	-40°C~+85°C
2.2	Storage Temp.	-50°C~+125°C
2.3	Altitude	45000 ft
2.4	Vibration	10g rms (15 degree 2KHz)
2.5	Humidity	100% RH at 35c, 95%RH at 40 deg c
2.6	Shock	20G for 11msc

3.0 Electrical Specifications		
3.1	Frequency Range	1.12~1.7GHz
3.2	Average Power	500W (CW)
3.5	VSWR	1.25:1 (max)

PAGE 1 OF 1		DATE	Jun 21 <sup>st</sup> 2006
<small>PROPRIETARY INFORMATION THE INFORMATION CONTAINED IN THIS DOCUMENT IS THE PROPERTY OF RF-LAMBDA EXCEPT AS SPECIFICALLY AUTHORIZED IN WRITINGS BY RF-LAMBDA. THE HOLDER OF THIS DOCUMENT SHALL KEEP ALL INFORMATION CONTAINED HEREIN CONFIDENTIAL AND SHALL PROTECT SAME IN THE WHOLE OR IN PART FROM DISCLOSURE AND DISSEMINATION OF ALL THIRD PARTIES AND SHALL USE SAME FOR OPERATING AND MAINTENANCE PURPOSES ONLY</small>		DESIGN	RFPC
		RF-LAMBDA	RFPC
		CAD MODEL REVISION	11
		ASSEMBLY REVISION	V55DS
 <b>RFWT650A WAVEGUIDE TERMINATION</b>		ASSEMBLY NAME	RFLVR05
		DRAWING NUMBER	D05-1
www.rflambda.com		RF-LAMBDA	SIZE LT
		SHEETS	1 OF 1