

Standards
NF C 96-315
MIL-DTL-39030

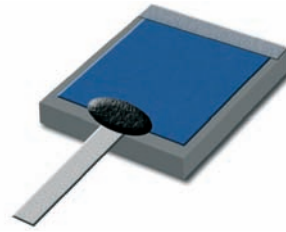

Substrate
Resistive film
Protection film
Tab
Tab attachment

AlN
Thick film
Epoxy
Ag
Braze with epoxy encapsulation

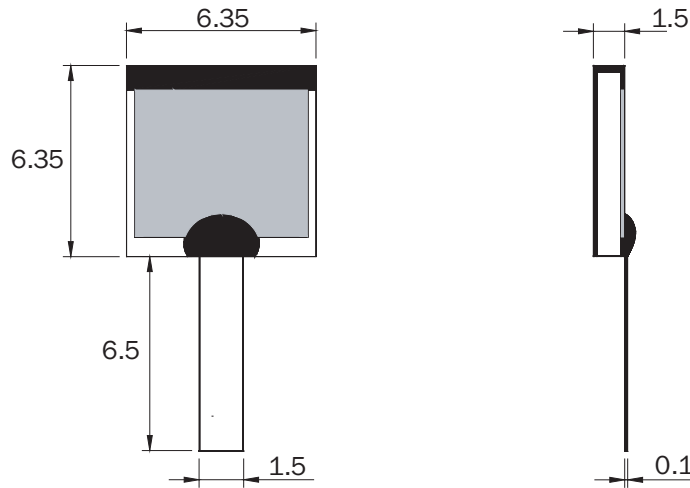
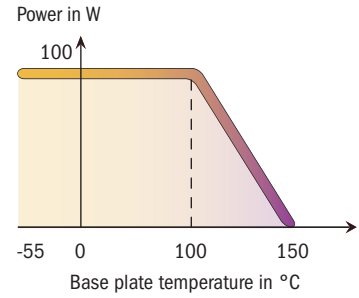

Dimensions in mm

| P/N | Frequency (GHz) | Power (W) | Impedance ($\Omega \pm 5\%$) | Max VSWR |
|---------|-----------------|-----------|--------------------------------|----------|
| 17-0495 | 4 | 100 | 50 | 1.25 |

| mm | inch |
|------|-------|
| 0.1 | 0.004 |
| 1.5 | 0.059 |
| 6.35 | 0.250 |
| 6.5 | 0.256 |