

10 dB Fixed Attenuator, N Male To N Female
 Directional Black Anodized Aluminum Heatsink
 Body Rated To 500 Watts Up To 2.4 GHz

TECHNICAL DATA SHEET

PE7085-10

Configuration

Design	Fixed, Directional Attenuator
Connector 1	N Male
Connector 2	N Female
Body Material and Plating	Black Anodized Aluminum Heatsink

Electrical Specifications * Values at 25°C, sea level

Description	Minimum	Typical	Maximum	Units
Frequency Range	DC		2.4	GHz
Impedance		50		Ohms
Attenuation Value		10		dB
Input Power			500	Watts
Peak Power			2	KWatts
VSWR			1.35:1	

Specifications by Frequency

Description	F1	F2	F3	F4	F5	Units
Range	DC to 1,000	1 to 2.4				MHz
VSWR	1.25:1	1.35:1				
Attenuation Accuracy	± 0.3	± 0.75				dB

Mechanical Specifications

Size	
Length	17 in [431.8 mm]
Width	6.75 in [171.45 mm]
Height	6 in [152.4 mm]
Weight	16 lbs [7.26 Kg]

Connectors

Description	Connector 1	Connector 2
Type	N Male	N Female

Compliance Certifications (visit www.Pasternack.com for current document)
 RoHS Compliant

Click the following link (or enter part number in "SEARCH" on website) to obtain additional part information including price, inventory and certifications: [10 dB Fixed Attenuator, N Male To N Female Directional Black Anodized Aluminum Heatsink Body Rated To 500 Watts Up To 2.4 GHz PE7085-10](#)

10 dB Fixed Attenuator, N Male To N Female
Directional Black Anodized Aluminum Heatsink
Body Rated To 500 Watts Up To 2.4 GHz

TECHNICAL DATA SHEET

PE7085-10

Plotted and Other Data

Notes:

- Values at 25 °C, sea level

Outline Drawing

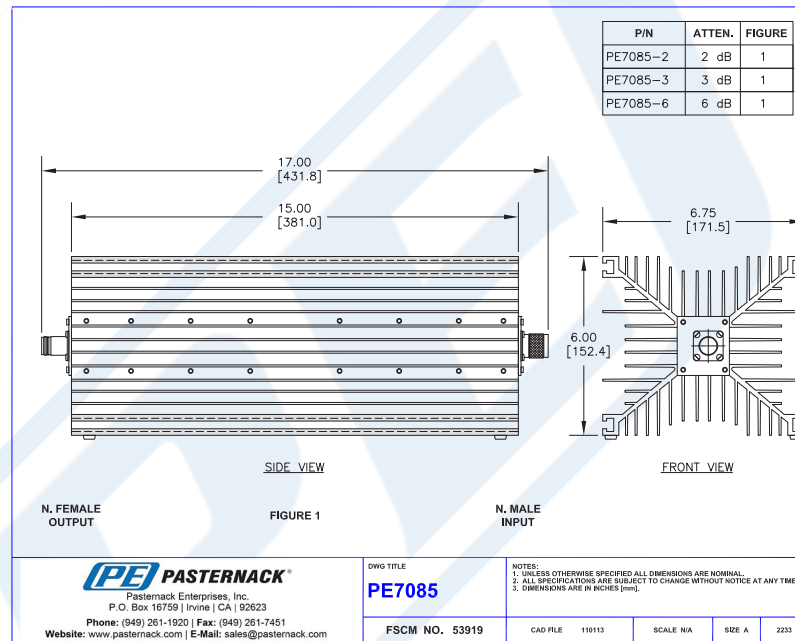

10 dB Fixed Attenuator, N Male To N Female Directional Black Anodized Aluminum Heatsink Body Rated To 500 Watts Up To 2.4 GHz from Pasternack Enterprises has same day shipment for domestic and International orders. Our RF, microwave and millimeter wave products maintain a 99% availability and are part of the broadest selection in the industry.

Click the following link (or enter part number in "SEARCH" on website) to obtain additional part information including price, inventory and certifications: [10 dB Fixed Attenuator, N Male To N Female Directional Black Anodized Aluminum Heatsink Body Rated To 500 Watts Up To 2.4 GHz PE7085-10](http://www.pasternack.com/10db-fixed-n-male-n-female-500-watts-attenuator-pe7085-10)

URL: <http://www.pasternack.com/10db-fixed-n-male-n-female-500-watts-attenuator-pe7085-10-p.aspx>