

|                       |        |           |
|-----------------------|--------|-----------|
| DWG NO.<br>0910-104-1 |        | REV.<br>A |
| PART NUMBER           | BODY   | CONTACT   |
| 0910-104-NH           | NICKEL | GOLD      |

PLATING PER SAN-TRON SPEC. 7.3.1-8

- 1.0 PERFORMANCE
- 1.1 FREQUENCY RANGE: DC-6 GHz
- 1.2 VOLTAGE RATING: 500V RMS (sea level)
- 1.3 NOMINAL IMPEDANCE: 50 OHMS
- 1.4 DWV: 1500 V RMS @ 60 Hz (sea level)
- 1.5 TEMPERATURE RANGE: -65° C TO +165° C
- 2.0 MATERIALS
- 2.1 DIELECTRICS: PTFE

- 2.2 CONTACT: BeCu
- 2.3 OTHER METAL PARTS: BRASS
- 3.0 FINISHES: SEE TABLE
- 4.0 MECHANICAL
- 4.1 INTERFACES PER MIL-STD-348

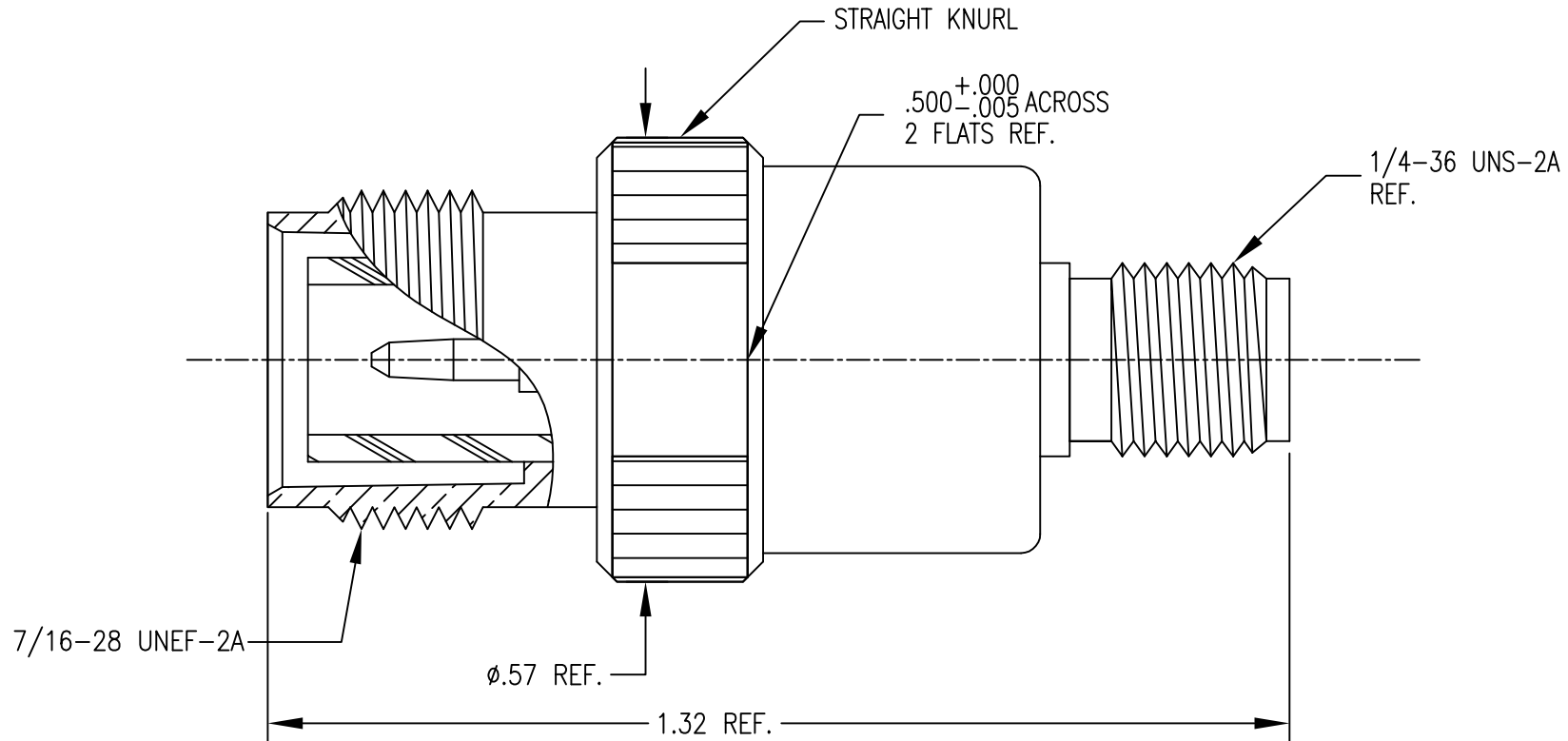

DO NOT SCALE DRAWING

|      |           |                    |  |                                |      |       |
|------|-----------|--------------------|--|--------------------------------|------|-------|
| A    |           | PRODUCTION RELEASE | NEW  | 12/29/09                       |      |       |
| Rev. | Revisions |                    | Disp.                                      | Date                           | Dwn. | Appd. |
|      |           | Ref.: SK-          | REMOVE ALL BURRS AND SHARP EDGES .005 MAX. | INTERPRET PER ASME Y14.5M-1994 |      |       |

THIS DRAWING CONTAINS CONFIDENTIAL INFORMATION PROPRIETARY TO SAN-TRON, INC. IT MUST NOT BE REPRODUCED OR DISCLOSED TO OTHERS OR USED IN ANY OTHER WAY, IN WHOLE OR PART EXCEPT AS AUTHORIZED IN WRITING BY SAN-TRON, INC.

UNLESS OTHERWISE SPECIFIED:  
ALL DIMENSIONS ARE IN INCHES.  
ALL DIMENSIONS ARE AFTER PLATING.  
.XXX = ±.005 ALL MACHINED SURFACES  $\sqrt{64}$  MAX.  
.XX = ±.01 ANG. ±1/2° FRACTIONAL = ±1/64  
Ⓢ.004 MAX. TIR

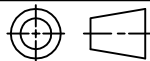

THIRD ANGLE PROJECTION

|      |     |          |
|------|-----|----------|
| DWN  | JTH | 12/22/09 |
| CHKD | SJS | 12/23/09 |
| APPR | FSH | 12/23/09 |



**SAN-TRON, INC.**  
4 NEWBURYPORT TPK. IPSWICH, MA USA 01938  
TEL: 978 - 356 -1585 FAX: 978 - 356 -1573  
WWW.SANTRON.COM E MAIL: santron@santron.com

TITLE ADAPTER, SMA (F) TO RPTNC (F)  
STRAIGHT

|            |           |         |            |
|------------|-----------|---------|------------|
| MATERIAL:  | SEE NOTES | FINISH: | SEE TABLE  |
| CAGE CODE: | 50896     | DWG NO. | 0910-104-1 |
| SCALE      | X:X       | REV.    | A          |