

- 267.5 MHz SAW Filter
- 5.0 X 5.0 mm Surface-mount Case
- Single-ended Input and Output
- Complies with Directive 2002/95/EC (RoHS)



**Absolute Maximum Ratings**

Rating	Value	Units
Maximum Incident Power in Passband	+13	dBm
Maximum DC Voltage on any Non-ground Terminal	30	VDC
Storage Temperature Range in Tape and Reel	-40 to +85	°C
Suitable for Lead-free Soldering - Maximum Soldering Temperature	260 °C for 30 s	

**SF2087C**

**267.5 MHz  
SAW Filter**

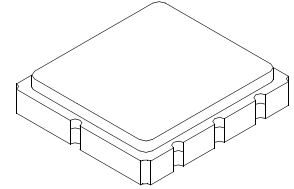

**SM5050-8**

**Electrical Characteristics**

Characteristic	Sym	Notes	Min	Typ	Max	Units
Center Frequency	$f_C$	1		267.5		MHz
Insertion Loss		1			13	dB
2 dB Bandwidth	$BW_{2.0}$	1	35	39		MHz
Amplitude Ripple, $f_C \pm 15$ MHz		1			1.5	dB <sub>P-P</sub>
Amplitude Ripple, $f_C \pm 15$ MHz, within adjacent 5 MHz windows		1			1.2	dB <sub>P-P</sub>
Group Delay Deviation, $f_C \pm 17.5$ MHz		1		100		ns <sub>P-P</sub>
Group Delay Deviation, $f_C \pm 15$ MHz within adjacent 5 MHz windows		1			50	ns <sub>P-P</sub>
VSWR at $f_C$		1		2.5:1		
40 dB Rejection Bandwidth		1, 2			65	MHz
Operating Temperature Range			-40		85	°C
Case Style			SM5050-8 5 x 5 mm Nominal Footprint			
Lid Symbolization (Y=year, WW=week, S=shift)			RFM 589 YWWS			

**Electrical Connections**

Connection		Terminals
Port 1	Input	1
Port 2	Output	5
	Ground	All others
Dot indicates Pin 1		



**CAUTION: Electrostatic Sensitive Device. Observe precautions for handling.**

**NOTES:**

1. Unless noted otherwise, all specifications apply over the operating temperature range with filter soldered to the specified demonstration board with impedance matching to 50 Ω and measured with 50 Ω network analyzer.
2. Rejection is measured as attenuation below the minimum IL point in the passband. Rejection in final user application is dependent on PCB layout and external impedance matching design. See Application Note No. 42 for details.
3. The design, manufacturing process, and specifications of this filter are subject to change.
4. Tape and Reel Standard ANSI / EIA 481.
5. Either Port 1 or Port 2 may be used for either input or output in the design. However, impedances and impedance matching may vary between Port 1 and Port 2, so that the filter must always be installed in one direction per the circuit design.
6. US and international patents may apply.
7. Murata, stylized Murata logo, and Murata N.A., Inc. are registered trademarks of Murata Manufacturing Co., Ltd.

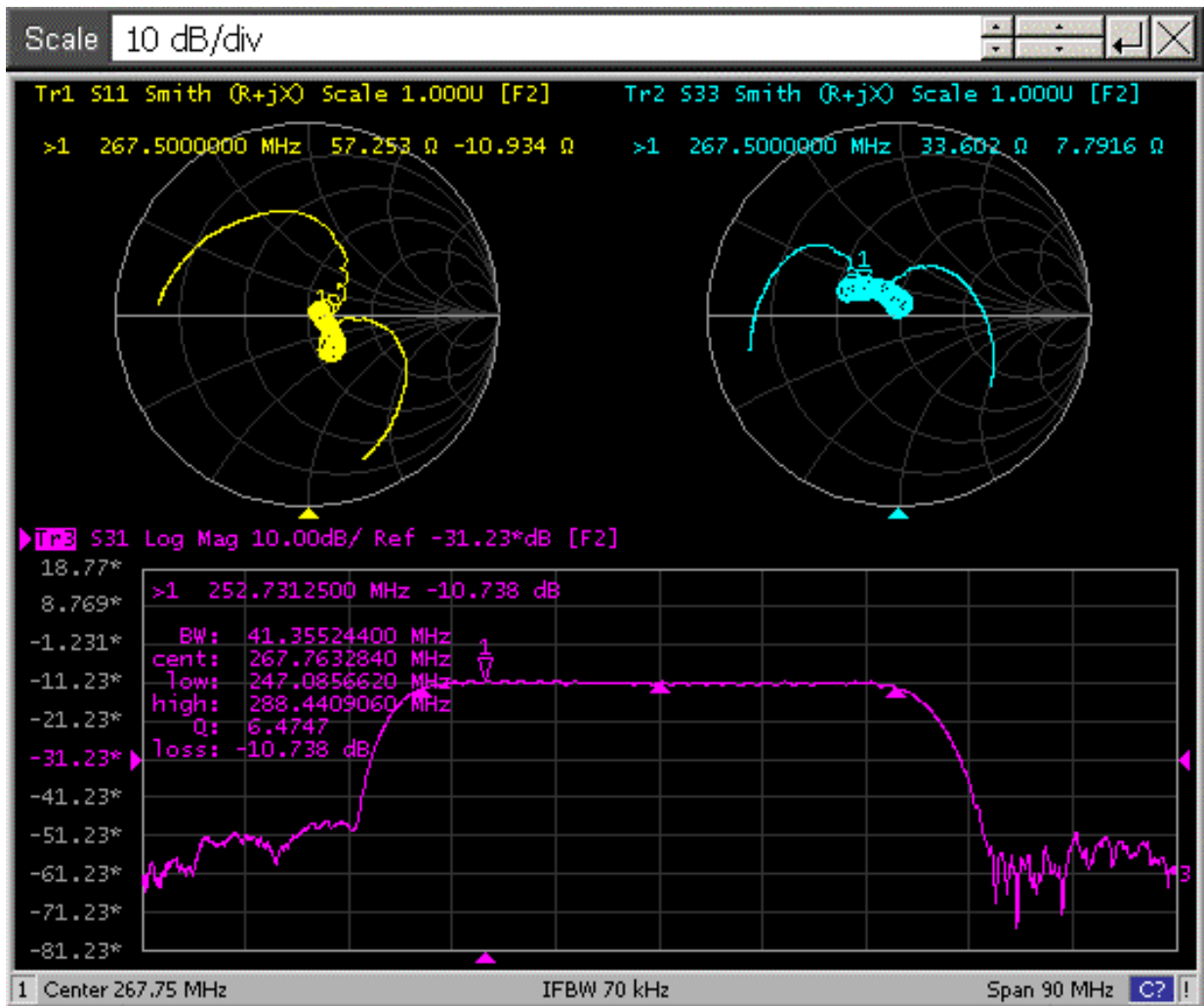

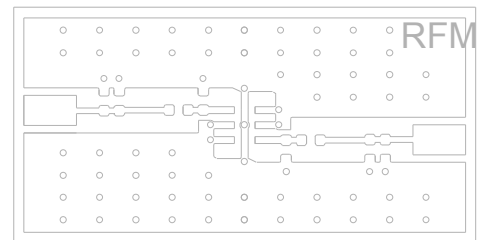
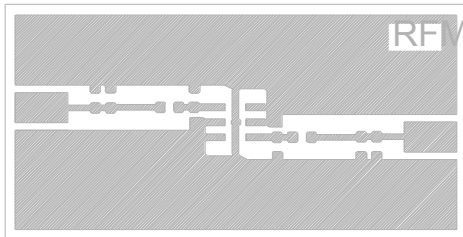
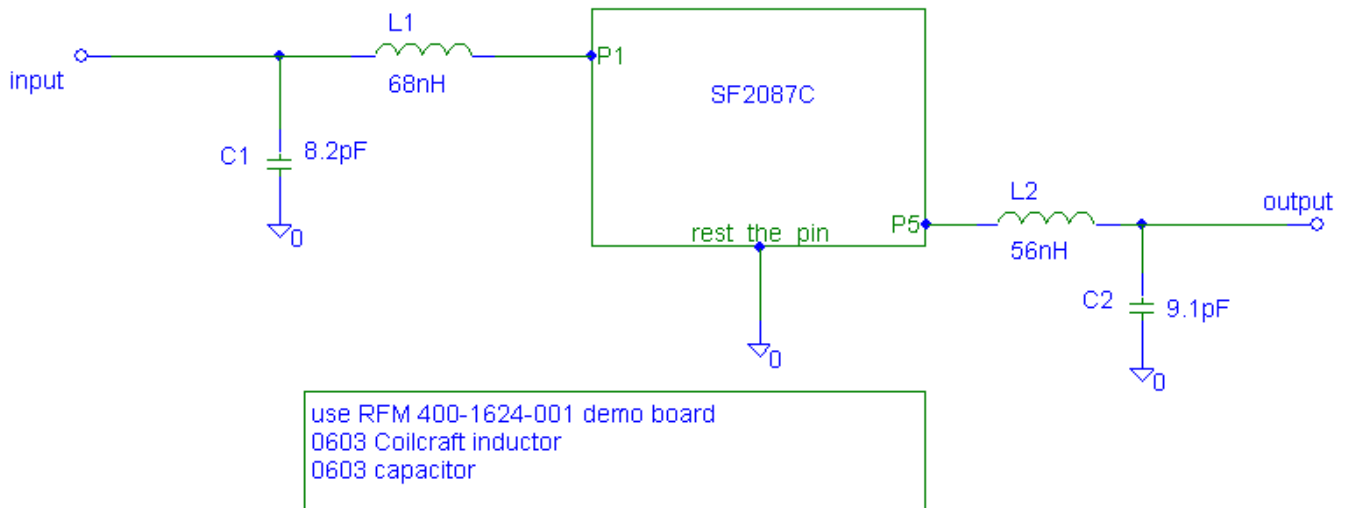

DRILL ALL HOLES #76 DRILL (0.020)  
ALL HOLES ARE PLATED THRU.

# SM5050-8 Surface-Mount 8-Terminal Ceramic Case 5.0 X 5.0 mm Nominal Footprint

## Case Dimensions

Dimension	mm			Inches		
	Min	Nom	Max	Min	Nom	Max
A	4.80	5.00	5.20	0.189	0.197	0.205
B	4.80	5.00	5.20	0.189	0.197	0.205
C	1.30	1.50	1.70	0.050	0.060	0.067
D	1.98	2.08	2.18	0.078	0.082	0.086
E	1.07	1.17	1.27	0.042	0.046	0.050
F	0.50	0.64	0.70	0.020	0.025	0.028
G	2.39	2.54	2.69	0.094	0.100	0.106
H		1.27			0.050	
I		0.76			0.030	
J		1.55			0.061	
K		2.79			0.110	
L		0.76			0.030	
M		2.36			0.093	
N		1.55			0.061	
O		2.79			0.110	
P		2.79			0.110	
Q		2.79			0.110	

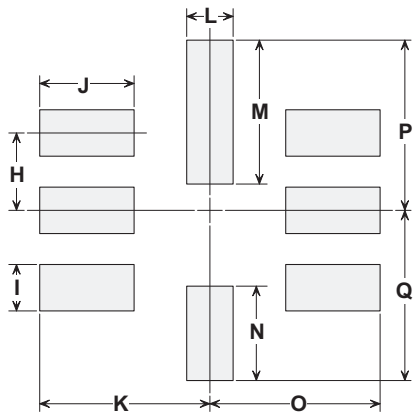
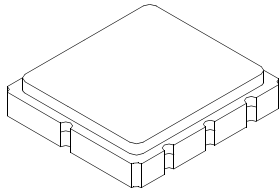

**PCB Footprint**

## Case Materials

Materials	
Solder Pad Plating	0.3 to 1.0 $\mu\text{m}$ Gold over 1.27 to 8.89 $\mu\text{m}$ Nickel
Lid Plating	2.0 to 3.0 $\mu\text{m}$ Nickel
Body	$\text{Al}_2\text{O}_3$ Ceramic
	Pb Free

**TOP VIEW**

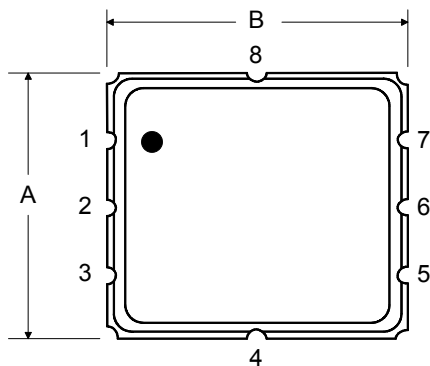

**BOTTOM VIEW**

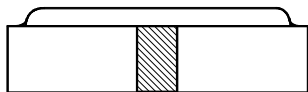
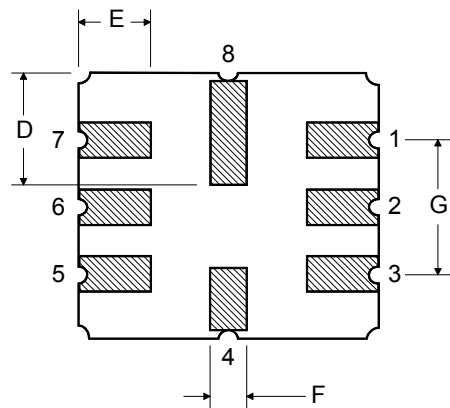

# Tape and Reel Specifications

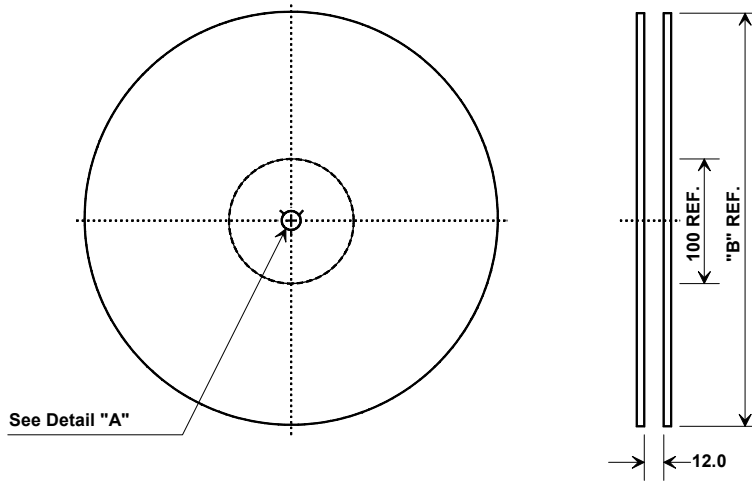

"B" Nominal Size		Quantity Per Reel
Inches	millimeters	
7	178	500
13	330	3000

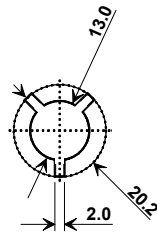

## COMPONENT ORIENTATION and DIMENSIONS

Carrier Tape Dimensions	
Ao	5.3 mm
Bo	5.3 mm
Ko	2.0 mm
Pitch	8.0 mm
W	12.0 mm

