

### Applications

- WiFi bandpass filter that enables the coexistence of 4G (WiMAX/LTE/TD-LTE) & WiFi signals
- Portable Hotspots and Mobile Routers
- Band-edge filtering of WiFi signal emissions
- Smart Meters
- High-power WLAN Access Points and Small Cells
- Applicable reject bands: 2.6 GHz WiMAX/LTE, TDD-LTE Bands 38 & 40

### Product Features

- Low Loss in WLAN band with extended upper corner for inclusion of Bluetooth
- High Rejection in B38/B40 bands
- Industry leading small size: 1.4 x 1.2 x 0.46 mm
- Performance over -40 to +95 °C
- Ceramic chip-scale Package (CSP)
- Hermetically sealed
- RoHS compliant, Pb-free

### General Description

The 885062 is a high-performance, high power Bulk Acoustic Wave (BAW) band-pass filter with extremely steep skirts, simultaneously exhibiting low loss in the WiFi band and high band-edge & near-in rejection.

The 885062 enables coexistence of WiFi and LTE signals within the same device or in close proximity to one another. Its unique power handling capability allows for implementation into access points and small cell base stations.

The 885062 uses common module packaging techniques to achieve the industry standard 1.4 x 1.2 x 0.46 mm footprint. The filter exhibits excellent power handling capabilities.

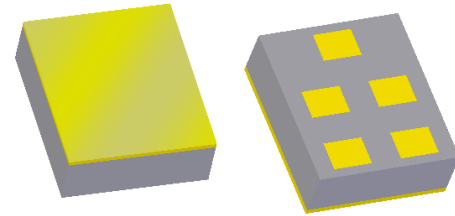

CSP-5CT package: 1.4 x 1.2 x 0.46 mm

### Functional Block Diagram

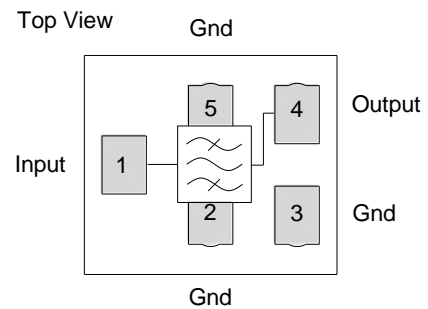

### Pin Configuration

Pin No.	Label
1	Input
4	Output
2,3,5	Ground

### Ordering Information

Part No.	Description
885062	Packaged part
885062-EVB	Evaluation board

Standard T/R size = 10,000 units/reel