

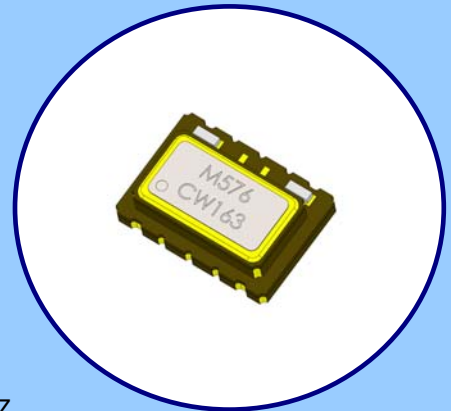

FEATURES

- CMOS Output
- Optional Voltage Control for Frequency Tuning [VCTCXO]
- 7.0mmx5.0mm Surface Mount Package
- Frequency Range 10 – 40 MHz [Standard Frequencies List Shown Below]
- Fundamental Crystal Design
- Frequency Stability, several options to choose from, $\pm 0.5\text{ppm} \sim \pm 5.0\text{ppm}$
- Operating Voltage, +2.8Vdc \sim +5.0Vdc
- Operating Temperature to -40°C to +85°C
- Tape & Reel Packaging Available
- RoHS/Green Compliant (6/6)



APPLICATIONS

The Model 576 Temperature Compensated Crystal Oscillator (TCXO) is a quartz based, CMOS output, analog temperature compensated oscillator with optional frequency tuning, in a hermetically sealed ceramic package. M576 is suitable for base stations, wireless communications, test and measurement, Femtocell, WLAN/WiMax/WIFI and mobile phone applications.

ORDERING INFORMATION

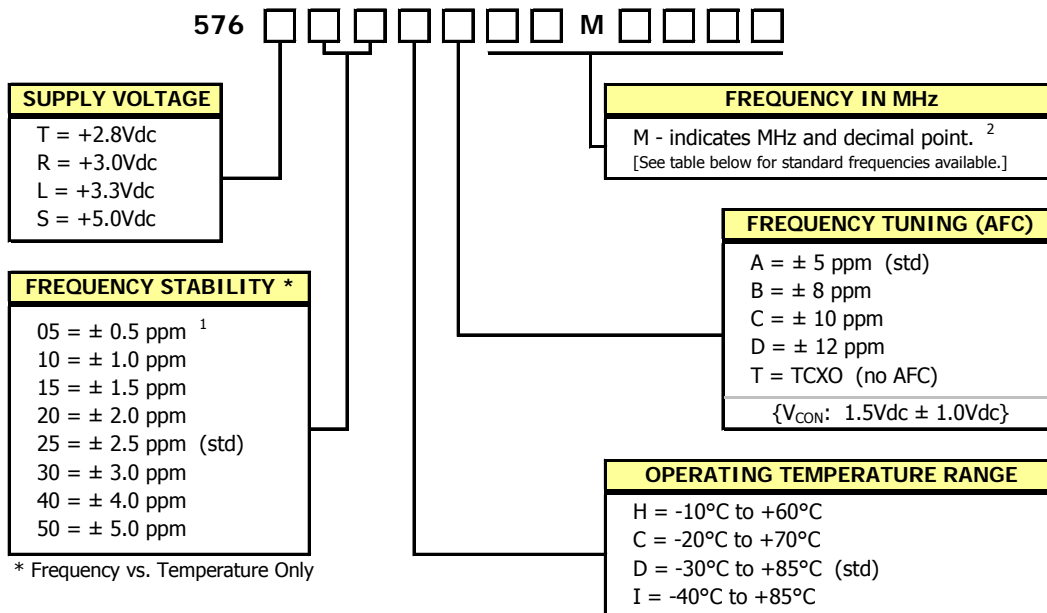

1] Only available with temperature range codes "H" and "C".
2] Frequency is recorded with two leading digits before the 'M' and 4 significant digits after the 'M' (including zeros).
[Ex. XXMXXXX (10M0000), XXMXXXX (16M3840)]

**Not all performance combinations and frequencies may be available.
Contact your local CTS Representative or CTS Customer Service for availability.**

| M576 Standard Frequencies | | | | | |
|---------------------------|------------|------------|------------|------------|------------|
| 10.000 MHz | 12.800 MHz | 16.800 MHz | 19.440 MHz | 24.576 MHz | 32.000 MHz |
| 10.240 MHz | 14.000 MHz | 18.000 MHz | 20.000 MHz | 25.000 MHz | 32.768 MHz |
| 12.000 MHz | 15.360 MHz | 18.432 MHz | 20.480 MHz | 26.000 MHz | 38.880 MHz |
| 12.288 MHz | 16.000 MHz | 19.200 MHz | 24.000 MHz | 27.000 MHz | 40.000 MHz |

ELECTRICAL CHARACTERISTICS

| PARAMETER | SYMBOL | CONDITIONS | MIN | TYP | MAX | UNIT |
|---|-------------------------------|--|------------------------------------|-----|---------------------|--------|
| Maximum Supply Voltage | V _{CC} | - | -0.6 | - | 6.0 | V |
| Maximum Control Voltage | V _C | - | -0.5 | - | V _{CC} | V |
| Storage Temperature | T _{STG} | - | -55 | - | 125 | °C |
| Frequency Range | f _O | Std frequencies listed in Ordering Information | 10 | - | 40 | MHz |
| Frequency Stability | Δf/f _O | Frequency vs. Temperature Only | 0.5,1.0,1.5,2.0 2.5,3.0,4.0,5.0 | | | ± ppm |
| Frequency Stability vs. Initial Calibration | - | @25°C | - | - | 1.0 | ± ppm |
| vs. Supply Voltage | | ±5% change | - | 0.3 | 0.5 | |
| vs. Load | | ±10% change | - | - | 0.2 | |
| vs. Reflow Shift | | After 2 reflows | - | - | 2.0 | |
| vs. Aging | | 1st year | - | - | 1.0 | |
| | | 10 year (Except stability code 05) | - | - | 8.0 | |
| Operating Temperature | T _A | - | -10 | 25 | 60 | °C |
| Order Code 'H' | | | -20 | | 70 | |
| Order Code 'C' | | | -30 | | 85 | |
| Order Code 'D' | | | -40 | | 85 | |
| Order Code 'I' | | | | | | |
| Supply Voltage | V _{CC} | ±5% | 2.66 | 2.8 | 2.94 | V |
| Order Code 'T' | | | 2.85 | 3.0 | 3.15 | |
| Order Code 'R' | | | 3.14 | 3.3 | 3.47 | |
| Order Code 'L' | | | 4.75 | 5.0 | 5.25 | |
| Order Code 'S' | | | | | | |
| Supply Current | I _{CC} | - | - | - | 6.0 | mA |
| Control Voltage | V _C | - | 0.5 | 1.5 | 2.5 | V |
| Frequency Tuning [VCTCXO Only] | - | V _C = 1.5V ±1.0V | 5,8,10,12 | | | ± ppm |
| V _C Input Impedance | Z _{V_C} | - | 100 | - | - | kOhm |
| Output Waveform | | DC coupled CMOS | | | | |
| Output Voltage Levels | | | | | | |
| Logic '1' Level | V _{OH} | CMOS Load | 0.9*V _{CC} | - | - | V |
| Logic '0' Level | V _{OL} | CMOS Load | - | - | 0.1*V _{CC} | |
| Output Load | C _L | - | - | - | 15 | pF |
| Rise and Fall Time | T _R T _F | @ 20% - 80% Levels | - | 3.0 | 6.0 | ns |
| Output Duty Cycle | SYM | @ 50% Level | 45 | - | 55 | % |
| Start Up Time | T _S | - | - | - | 2 | ms |
| Phase Noise ¹ | - | - | | | | dBc/Hz |

Notes:

1. Phase Noise performance may vary based on output frequency. See example plot at 10 MHz below.

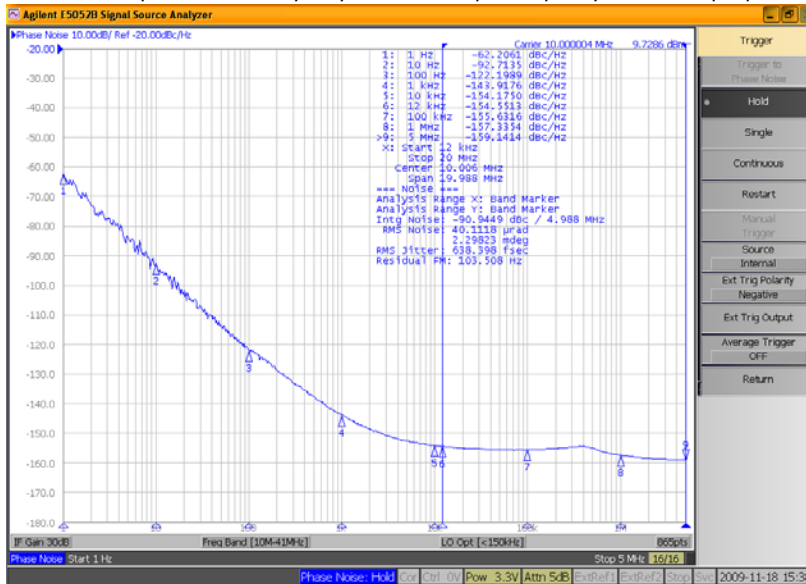

SINGLE SIDE BAND PHASE NOISE
(typical maximums @ 10 MHz)

| Frequency Offset | Phase Noise (dBc/Hz) |
|------------------|----------------------|
| 10 Hz | -95 |
| 100 Hz | -120 |
| 1k Hz | -140 |
| 10k Hz | -148 |

MECHANICAL SPECIFICATIONS

PACKAGE DRAWING

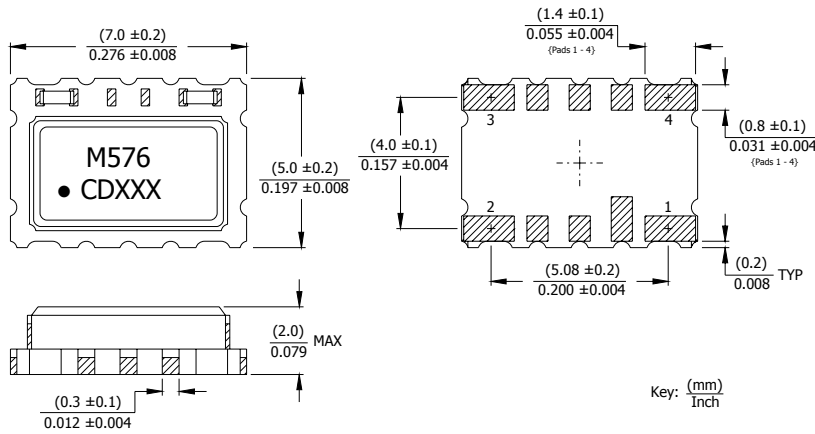

MARKING INFORMATION

1. M576 - CTS Model Series.
2. ● - Pin 1 identifier.
3. C - CTS identifier.
4. D - Date code. See Table II for codes.
5. XXX - Frequency code. See Table I for codes.

Complete CTS part number, frequency value and date code information must appear on reel and carton labels.

NOTES

1. DO NOT make connections to non-labeled pins. Castellation pins may have internal connections used in the manufacturing process.
2. Termination pads (e4); barrier plating is nickel (Ni) with gold (Au) flash plate.
3. Reflow conditions per JEDEC J-STD-020, 260°C maximum.

SUGGESTED SOLDER PAD GEOMETRY

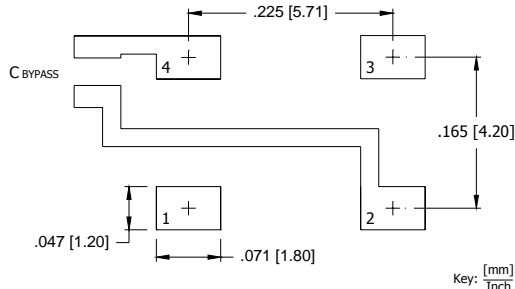

C_{BYPASS} should be ≥ 0.01 uF.

TABLE I – FREQUENCY CODING

| FREQUENCY | MARKING CODE | FREQUENCY | MARKING CODE | FREQUENCY | MARKING CODE | FREQUENCY | MARKING CODE |
|------------|--------------|---------------|--------------|------------|--------------|------------|--------------|
| 10.000 MHz | 100 | 15.360 MHz | 153 | 18.432 MHz | 184 | 25.000 MHz | 250 |
| 10.240 MHz | 102 | 16.000 MHz | 160 | 19.200 MHz | 192 | 26.000 MHz | 260 |
| 12.000 MHz | 120 | 16.367 MHz | 16A | 19.440 MHz | 194 | 27.000 MHz | 270 |
| 12.288 MHz | 122 | 16.367667 MHz | 16B | 19.680 MHz | 196 | 32.000 MHz | 320 |
| 12.800 MHz | 128 | 16.368 MHz | 16C | 19.800 MHz | 198 | 32.512 MHz | 325 |
| 13.000 MHz | 130 | 16.369 MHz | 16D | 19.998 MHz | 199 | 32.768 MHz | 327 |
| 13.500 MHz | 135 | 16.384 MHz | 163 | 20.000 MHz | 200 | 38.880 MHz | 388 |
| 14.000 MHz | 140 | 16.800 MHz | 168 | 20.480 MHz | 204 | 40.000 MHz | 400 |
| 14.400 MHz | 144 | 18.000 MHz | 180 | 24.000 MHz | 240 | | |

Not all frequencies listed may be available for this design.

TABLE II – DATE CODE

| YEAR | | MONTH | | | | | JAN | FEB | MAR | APR | MAY | JUN | JUL | AUG | SEP | OCT | NOV | DEC |
|------|------|-------|------|------|------|------|-----|-----|-----|-----|-----|-----|-----|-----|-----|-----|-----|-----|
| | | 2001 | 2005 | 2009 | 2013 | 2017 | | | | | | | | | | | | |
| 2001 | 2005 | 2009 | 2013 | 2017 | | A | B | C | D | E | F | G | H | J | K | L | M | |
| 2002 | 2006 | 2010 | 2014 | 2018 | | N | P | Q | R | S | T | U | V | W | X | Y | Z | |
| 2003 | 2007 | 2011 | 2015 | 2019 | | a | b | c | d | e | f | g | h | j | k | l | m | |
| 2004 | 2008 | 2012 | 2016 | 2020 | | n | p | q | r | s | t | u | v | w | x | y | z | |

TEST CIRCUIT – RL//CL LOAD

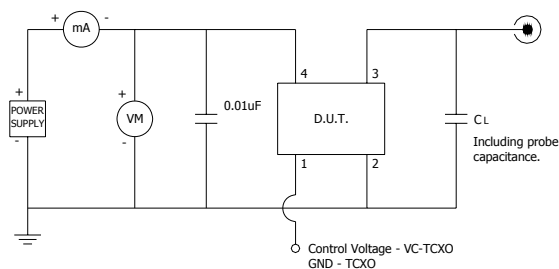

D.U.T. PIN ASSIGNMENTS

| PIN | SYMBOL | DESCRIPTION |
|-----|-----------------|---|
| 1 | V _C | Control Voltage – VCTCXO (Note 1) GND - TCXO |
| 2 | GND | Circuit & Package Ground |
| 3 | Output | CMOS Output |
| 4 | V _{CC} | Supply Voltage |

NOTES

1. Connect to ground for TCXO (no AFC) option.

PACKAGING INFORMATION

Device quantity is 1,000 pieces per 180mm reel.

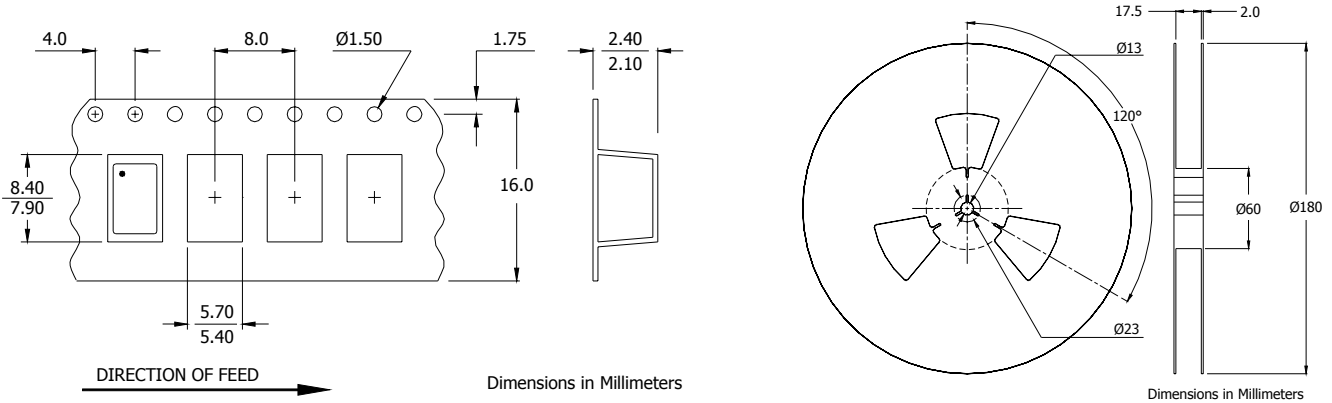

ENVIRONMENTAL SPECIFICATIONS

| | |
|----------------------------------|--|
| Temperature Cycle: | 400 cycles from -55°C to +125°C, 10 minute dwell at each temperature, 1 minute transfer time between temperatures. |
| Mechanical Shock: | 1,500g's, 0.5mS duration, 1/2 sinewave, 3 shocks each direction along 3 mutually perpendicular planes (18 total shocks). |
| Sinusoidal Vibration: | 0.06 inches double amplitude, 10 to 55 Hz and 20g's, 55 to 2,000 Hz, 3 cycles each in 3 mutually perpendicular planes (9 times total). |
| Gross Leak: | No leak shall appear while immersed in an FC40 or equivalent liquid at +125°C for 20 seconds. |
| Fine Leak: | Mass spectrometer leak rates less than 2×10^{-8} ATM cc/sec air equivalent. |
| Resistance to Solder Heat: | Product must survive 3 reflows of +250°C maximum, 10 seconds maximum. |
| High Temperature Operating Bias: | 2,000 hours at +125°C, disregarding frequency shift. |
| Frequency Aging: | 1,000 hours at +85°C. |
| Insulation Resistance: | 500M Ohms @ 100V _{DC} ±15V _{DC} . |
| Moisture Sensitivity Level: | Level 1 per JEDEC J-STD-020. |