

# 7/16 MALE LMR 400 CONNECTOR CRIMP/SOLDER

SC4947

## SPECIFICATIONS

### ELECTRICAL

FREQUENCY: 0-6 GHZ  
IMPEDANCE: 50 OHMS  
VSWR: 1.20:1 MAX

### MECHANICAL

MATERIALS BODY: TRIMETAL PLATED BRASS  
MATERIALS CONTACTS: SI PLATED BRASS  
MATERIALS COUPLING NUT: TRIMETAL PLATED BRASS  
INSULATOR: TEFLON

ROHS COMPLIANT

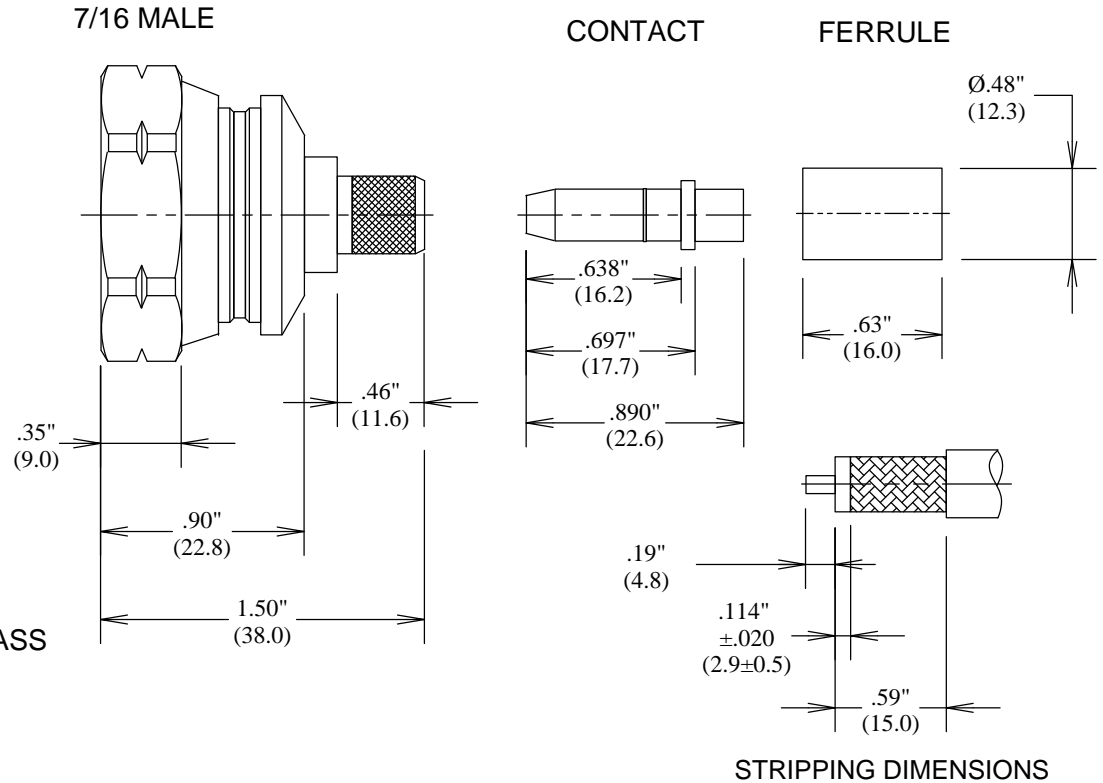

				<b>FAIRVIEW MICROWAVE INC.</b>			
				ALLEN, TX 75013 WWW.FAIRVIEWMICROWAVE.COM			
				TITLE			
				<b>7/16 MALE LMR 400 CONNECTOR CRIMP/SOLDER</b>			
				SIZE	CAGE CODE	DWG NO	REV
				ALL DIMENSIONS IN inches(MM) Typical			
				SCALE	SHEET		