

TITLE: SPECIFICATION CONTROL DRAWING

PART IDENTIFIER: TS03XXW3
(XX) DB VALUE

DESCRIPTION: CHIP ATTENUATOR

ASSEMBLY DWG: 1900274

1.0 SPECIFICATIONS:

- 1.1 ELECTRICAL:
 - 1.1.1 IMPEDANCE: 50 OHMS NOMINAL.
 - 1.1.2 FREQUENCY RANGE: DC-8 GHZ.
 - 1.1.3 ATTENUATION VALUES AVAILABLE: 0-20 DB IN 1 DB INCREMENTS.
 - 1.1.4 ATTENUATION ACCURACY: SEE TABLE.

ATTENUATION ACCURACY		
DB	DC - 4 GHZ	4 - 8 GHZ
0	-0,+0.3	-0,+0.5
1 -3	±0.3	±0.5
4 - 6	±0.4	±0.5
7 - 10	±0.5	±0.5
11 - 15	±0.75	+0.5,-3.0
16 - 20	±1.0	+0.5,-4.0

- 1.1.5 VSWR: DC - 4 GHZ - 1.25.
4 - 8 GHZ - 1.35.
- 1.1.6 INPUT POWER: 2 WATTS CW.
 - 1.1.6.1 FULL RATED POWER TO 125°C, DERATED LINEARLY TO 0 WATTS AT 150°C.
 - 1.1.6.2 PEAK POWER, 50 WATTS FOR 10US PULSE WIDTH @ 1% DUTY CYCLE.
- 1.2 MECHANICAL:
 - 1.2.1 OUTLINE DWG: SEE SHEET 2.
 - 1.2.2 WORKMANSHIP: PER MIL-PRF-55342.
- 1.3 ENVIRONMENTAL:
 - 1.3.1 ALTITUDE:
 - 1.3.1.1 NON-OPERATING: SEA LEVEL TO 50,000 FEET.
 - 1.3.1.2 OPERATING: SEA LEVEL TO 50,000 FEET.
 - 1.3.2 TEMPERATURE RANGE:
 - 1.3.2.1 NON-OPERATING: -55 C TO +150 C.
 - 1.3.2.2 OPERATING: -55°C TO +150°C.
 - 1.3.3 VIBRATION: PER MIL-STD-202, METHOD 204, COND. D.
 - 1.3.4 SHOCK: PER MIL-STD-202, METHOD 213, COND. I.
 - 1.3.5 MOISTURE RESISTANCE: PER MIL-STD-202, METHOD 106 EXCEPT SUBCYCLE STEPS 7A AND 7B AND POLARIZATION AND LOAD ARE NOT APPLICABLE.
- 1.4 ELECTROSTATIC DISCHARGE CONTROL: PER MIL-STD-1686.

2.0 UNIT MARKING: "DB VALUE". LEGIBILITY AND PERMANENCY PER MIL-STD-130.

3.0 QUALITY ASSURANCE:

- 3.1 SAMPLE INSPECT PER ANSI/ASQC Z1.4 GENERAL INSPECTION, LEVEL II, AQL = 1.0.
 - 3.1.1 VISUAL AND MECHANICAL EXAMINATION FOR CONFORMANCE TO OUTLINE DWG REQUIREMENTS.
- 3.2 PERFORM INSPECTION IN ACCORDANCE WITH 824W170 AND 824F036 FOR COMMERCIAL GRADE PRODUCT.
- 3.3 TEST DATA REQUIREMENTS:
 - 3.3.1 NO TEST DATA REQUIRED FOR CUSTOMER.
 - 3.3.2 DATA RETENTION – 24 MONTHS.

4.0 PACKAGING: STANDARD PACK PER 755W002.

EMC TECHNOLOGY 8851 SW OLD KANSAS AVE STUART, FLORIDA 34997	CAGE CODE # 24602		DWG #	1004125000
	CHANGE NOTICE	EN 10-0911	REV LVL	M
			SHEET	1 OF 2

PART ID REF

TS03XXW3

PROTECTIVE COATING
TOP ONLY

HATCHED AREA
REPRESENTS
METALIZATION

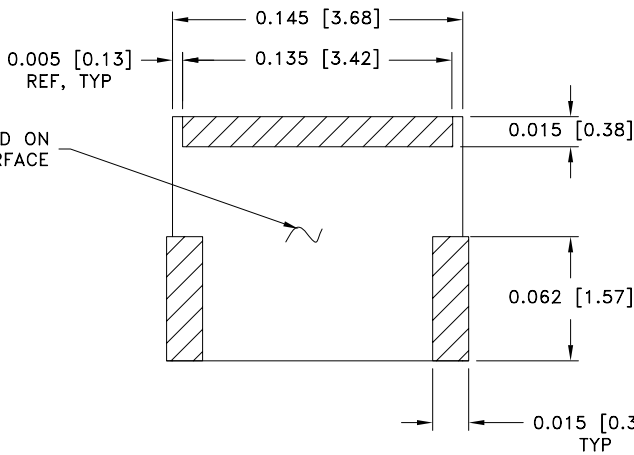
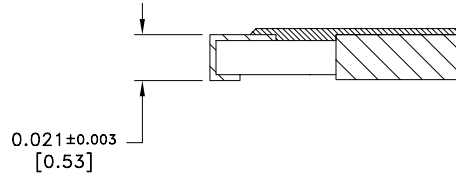
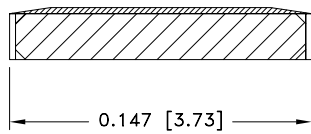
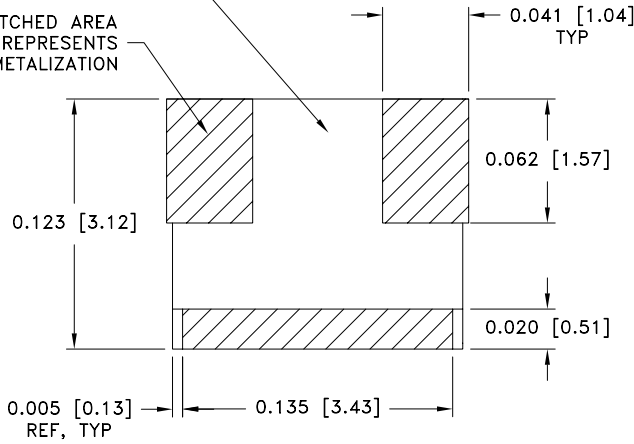

UNITS MARKED ON
THIS SURFACE

MECHANICAL SPECIFICATIONS:

SUBSTRATE:
MATERIAL - ALUMINA, MIL-I-10.
TERMINAL:
MATERIAL - THICK FILM, NICKEL BARRIER,
SOLDER PLATED.
RESISTIVE ELEMENT:
MATERIAL - THIN FILM TANTALUM NITRIDE.

METRIC EQUIVALENTS GIVEN IN [mm]
FOR REFERENCE INFORMATION ONLY

POWER RATING AND DERATING

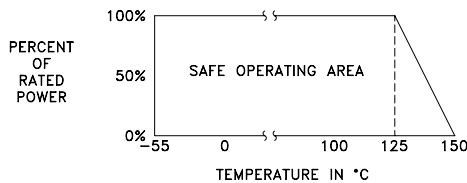

8851 SW OLD KANSAS AVE
STUART, FL 34997
PHONE NO. (772)286-9300
FAX NO. (772)283-5286

UNLESS OTHERWISE
SPECIFIED DIMENSIONS
ARE IN INCHES

TOLERANCES

FRACT	---
ANG	---
XX	---
XXX	±0.005
XXXX	---

THESE DRAWINGS AND SPECIFICATIONS ARE THE PROPERTY OF EMC TECHNOLOGY INC AND SHALL NOT BE DUPLICATED OR USED AS BASIS FOR THE MANUFACTURE OR SALE OF PARTS OR DEVICES WITHOUT PERMISSION.

CAGE CODE	SCALE	DRAWN BY	CHECKED BY	APPROVED BY
24602	16:1	CME 09/25/2001		FJV 9/25/01
REV	CHANGE NOTICE	DRAWING NO	SHEET	
M	EN 10-0911	1004125000	2 OF 2	