

# Xinger®

## Ultra Low Profile 1608 Balun 50Ω to 50Ω Balanced

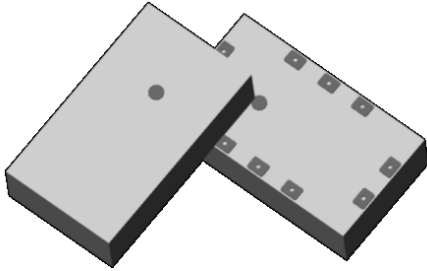

### Description

The BD0205F5050A00 is a low profile sub-miniature balanced to unbalanced transformer designed for differential input locations on data conversion devices such as A to D and D to A converters. In an easy to use surface mount package covering 70 MHz to 1000 MHz and with CMRR performances over 2x that of the incumbent wire wound products, this transformer is optimized to offer improved SFDR management during operation of the data converter device. The BD0205F5050A00 is ideal for high volume manufacturing and is higher performance and smaller form factor than traditional wire wound transformers. The BD0205F5050A00 has an unbalanced port impedance of 50Ω and a 50Ω balanced port impedance. This transformation enables single ended signals to be applied to differential ports on the data converter devices. The output ports have equal amplitude (-3dB) with 180 degree phase differential. The BD0205F5050A00 is available on tape and reel for pick and place high volume manufacturing.

### Detailed Electrical Specifications: Specifications subject to change without notice.

| Features:  | Parameter                 | ROOM (25°C) |      |      |      |      |     | Unit    |
|--|---------------------------|-------------|------|------|------|------|-----|---------|
|  |                           | Min.        | Typ. | Max  | Min. | Typ. | Max |         |
| <ul style="list-style-type: none"> <li>• 70 – 1000 MHz (IL 3dB BW)</li> <li>• 200-500 MHz ( IL 1dB BW)</li> <li>• 0.83 mm Height Profile</li> <li>• 50 Ohm to 2 x 25 Ohm</li> <li>• Excellent CMRR (36dB typical)</li> <li>• Input to Output DC Isolation</li> <li>• Surface Mountable</li> <li>• Tape &amp; Reel</li> <li>• Non-conductive Top Surface</li> <li>• RoHS Compliant</li> </ul> | Frequency                 | 70          |      | 1000 | 200  |      | 500 | MHz     |
|  | Unbalanced Port Impedance |             | 50   |      |      | 50   |     | Ohm     |
|  | Balanced Port Impedance   |             | 50   |      |      | 50   |     | Ohm     |
|  | Return Loss               | 4           | 4.6  |      | 11   | 13   |     | dB      |
|  | Insertion Loss*           |             | 3.0  | 3.4  |      | 0.9  | 1.1 | dB      |
|  | Amplitude Balance         |             | 0.2  | 0.6  |      | 0.2  | 0.6 | dB      |
|  | Phase Balance             |             | 1    | 3    |      | 1    | 3   | Degrees |
|  | CMRR                      |             | 36   |      |      | 36   |     | dB      |
|  | Power Handling            |             |      | 2    |      |      | 2   | Watts   |
|  | Operating Temperature     | -55         |      | +85  | -55  |      | +85 | °C      |

\* Insertion Loss stated at room temperature (Insertion Loss is approximately 0.1 dB higher at +85 °C)

### Outline Drawing

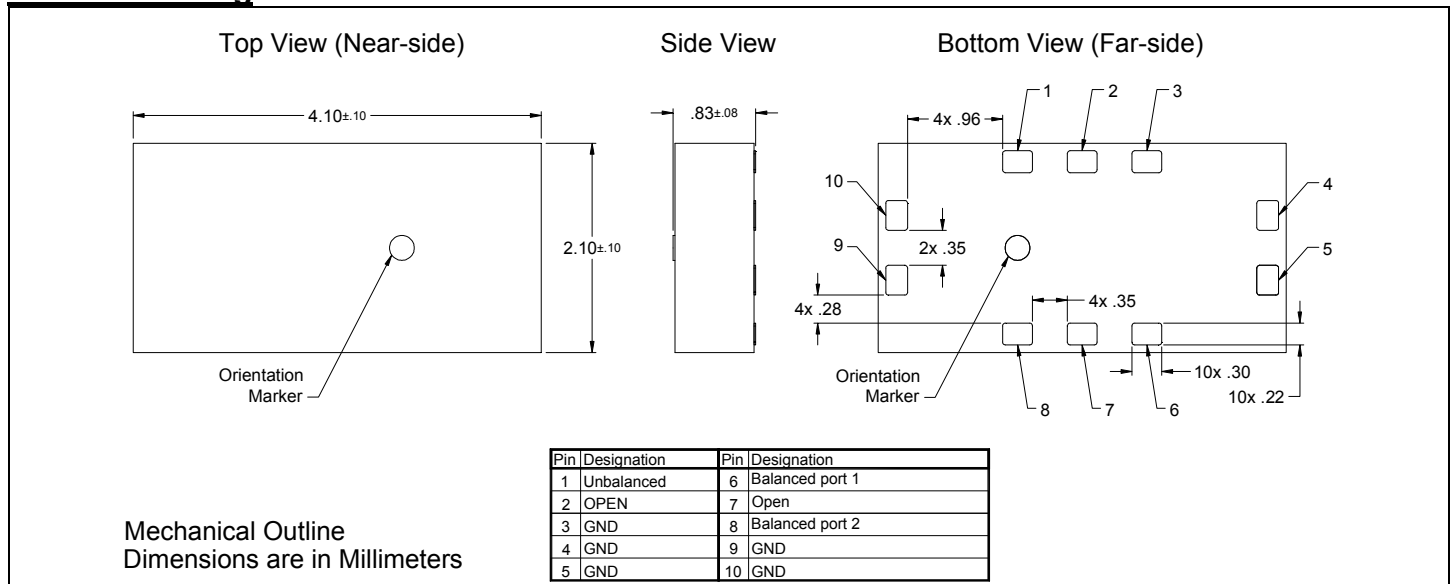

## Typical Broadband Performance: 0 - 8.0 GHz.

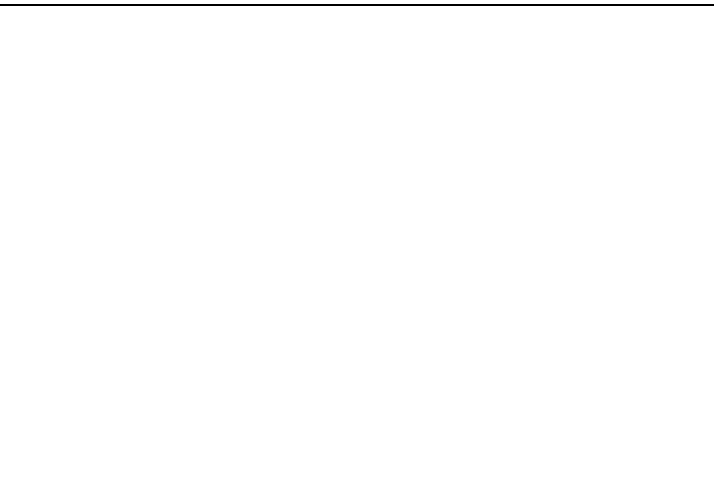
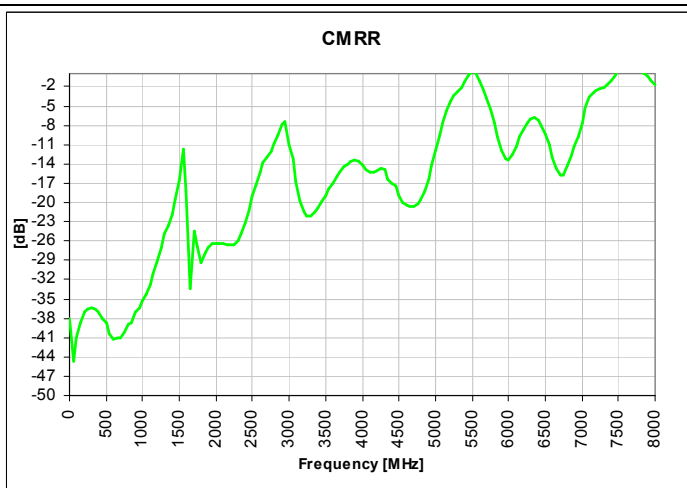
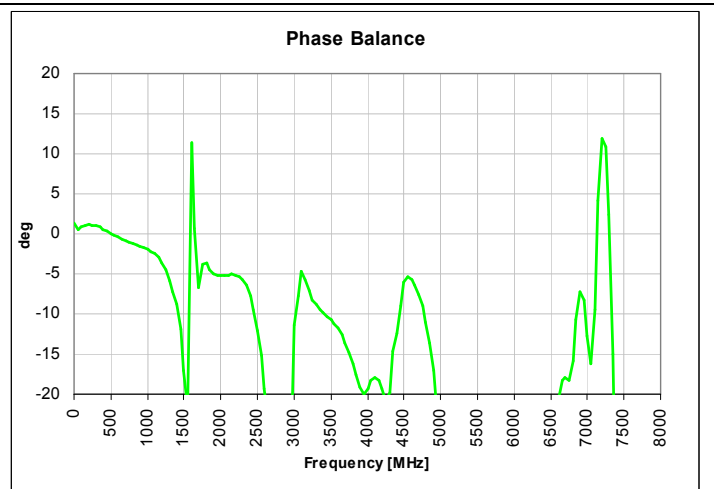
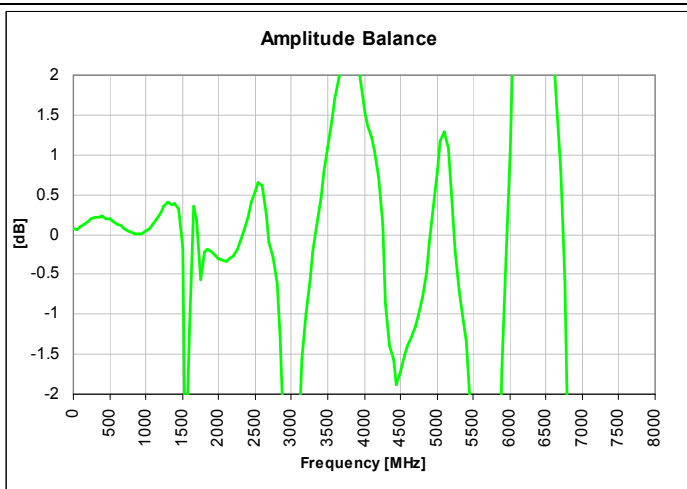
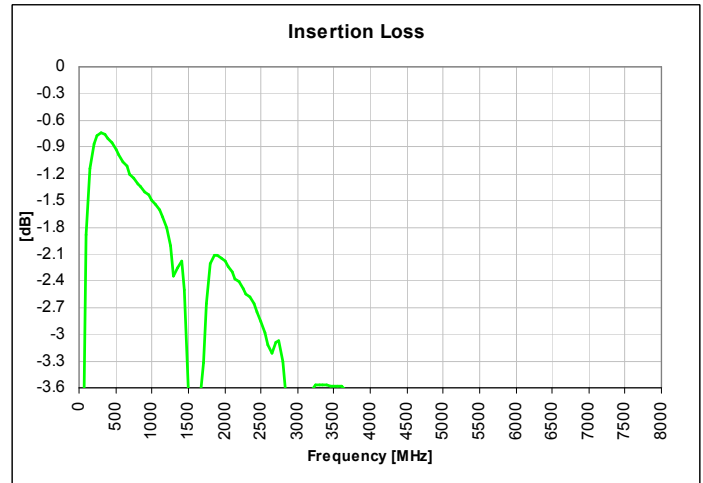
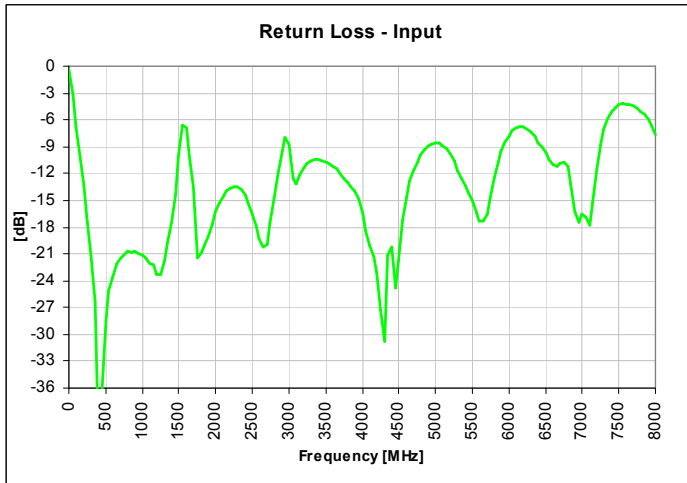

### Typical Performance: 0 MHz. to 1000 MHz.

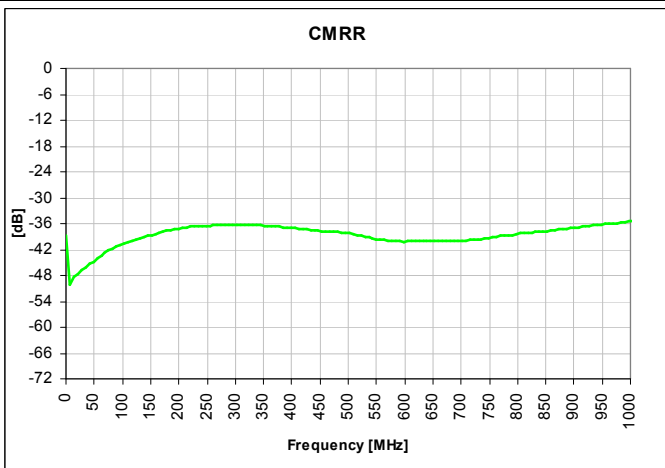
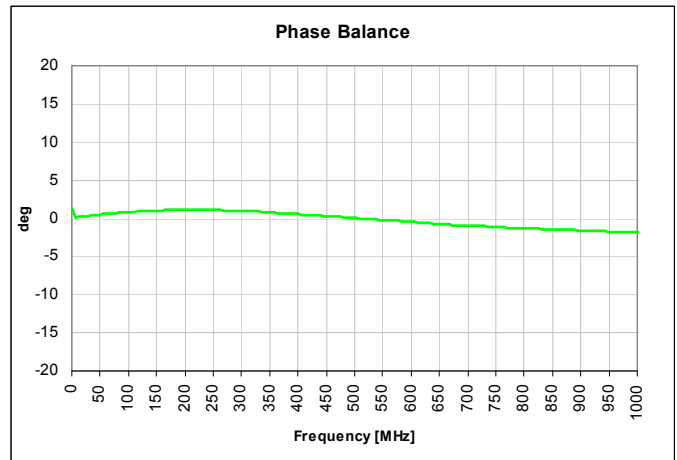
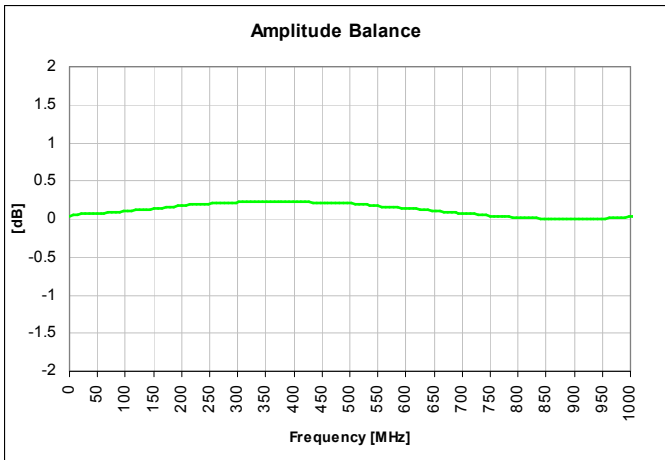
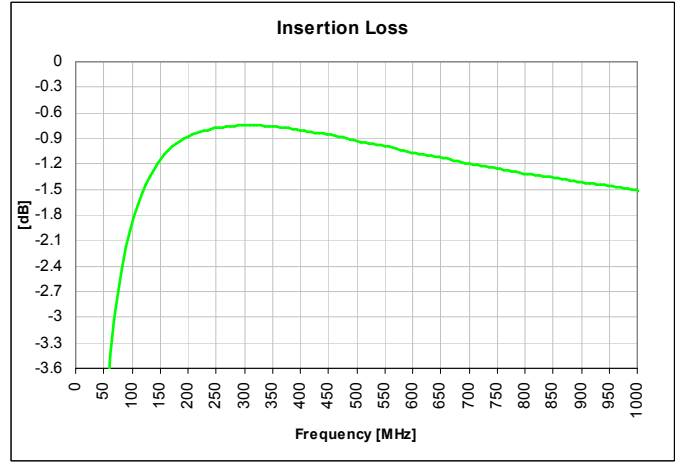
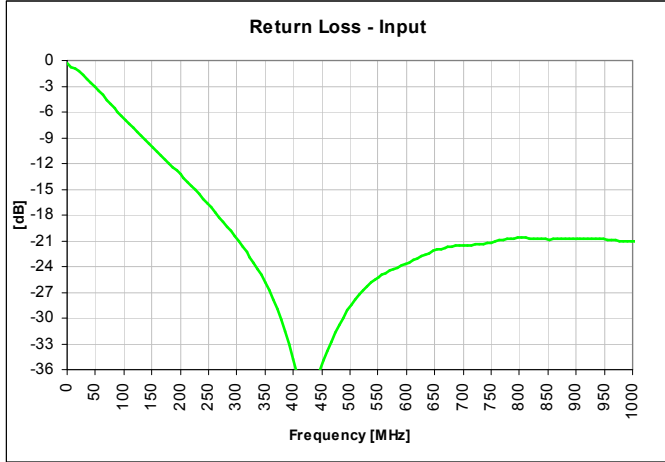

## Application in ADC Frontend:

Modern Analog-to-Digital Converter (ADC) system often uses differential architecture to suppress the even-order harmonics, minimize noise interference and keep dynamic range high. The ADC system can be heavily influenced by amplitude and phase imbalances arising from the ADC frontend, especially in high frequency applications. Anaren's multi-layer balun BD0205F5050A00 offers superb amplitude and phase balance performance over wide frequency range, translating to excellent SFDR system performance. BD0205F5050A00 is a ferrite free design eliminating related inter-modulation and other non-linear effects. BD0205F5050A00 provides wideband impedance match, resulting in improvement of gain flatness at high frequencies, which in turn reduces input drive requirements. Anaren's highly repeatable manufacturing process results in little part to part variation, ensuring consistent performance in production.

The schematic of a typical ADC front end application is shown below. In conjunction with many high speed ADC ICs, a bandwidth of 70MHz to 250MHz can be obtained for -1dB ripple of gain flatness. Differential load R1 and R2 are 33 ohm, slightly higher than the theoretical 25 ohm, to increase the voltage gain and reduce the required input drive, while keeping acceptable return loss. The series resistors, R5, R6, R7 and R8 are used to limit the amount of charge injection and optimize SFDR performance. Optional RC circuits, R3, R4, C4 and C5 can further improve SDFR in many circumstances by supplying an additional current path to neutralize the charge injection. These values are also chosen to limit or extend the ADC application bandwidth.

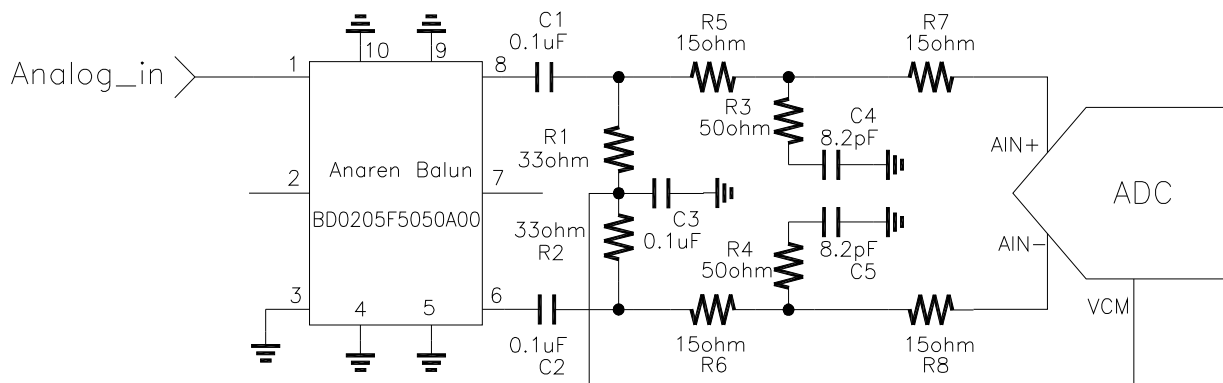

Typical ADC frontend schematic using BD0205F5050A00

### **Mounting Configuration:**

In order for Xinger surface mount components to work optimally, the proper impedance transmission lines must be used to connect to the RF ports. If this condition is not satisfied, insertion loss, Isolation and VSWR may not meet published specifications.

All of the Xinger components are constructed from organic PTFE based composites which possess excellent electrical and mechanical stability. Xinger components are compliant to a variety of ROHS and Green standards and ready for Pb-free soldering processes. Pads are Gold plated with a Nickel barrier.

An example of the PCB footprint used in the testing of these parts is shown below. In specific designs, the transmission line widths need to be adjusted to the unique dielectric coefficients and thicknesses as well as varying pick and place equipment tolerances.

