

VFTX210

Low Noise TCXO to 1.0 GHz

Sine Wave Output



Features

- 200MHz to 1.0 GHz Frequency Range
- Ultra Low Jitter and Phase Noise: -121 dBc/Hz @ 1KHz
- Excellent frequency stability < 1ppm
- Low Power: <240mW typical

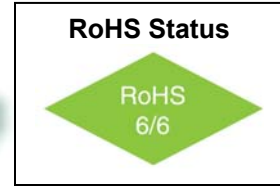
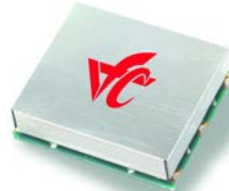

Applications

- Sonet / SDH / ATM
- 10 Gigabit Ethernet
- Digital Wireless Reference

Description

The VFTX210 is a low noise TCXO capable of providing a sine wave output frequency up to 1 GHz. The temperature stability is less than 1ppm over a temperature range of -40°C to + 85°C. Operating with a +3.3 volt power supply the device typically consumes 240mW. The device contains an internal voltage regulator for improved stability and noise performance. The VFTX210 is available in a 20.0 mm x 20.0 mm surface mount package.

Electrical Specifications

Parameter	Symbol	Condition	Min	Typ	Max	Unit	Note
Frequency Range	Fout		200		1,000	MHz	
Frequency Stability	$\Delta F/F$	Vs. Operating Temperature B: 0°C to +70°C G: -40°C to +85°C		0.5 0.8	1.0 1.0	ppm	
		Vs. Supply Voltage Vs. Aging / Year Vs. Aging / 10 Years		± 0.1 ± 1 ± 3		ppm/V ppm ppm	First Year 10 Years
Operating Temperature Range	Ta		0° -40°		+70° +85°	°C	Order Code B Order Code G
Output		Signal	Sine Wave				
Output Level	Po	50 Ω Load, Fout > 500 MHz	6	8		dBm	
		50 Ω Load, Fout < 500 MHz	8	10		dBm	
Subharmonics				-42	-36	dBc	
Voltage Control	Vc		0	1.5	3.0	V	
Input Impedance	Zin		50 Ω + 1000pf // 15K Ω				
APR			± 5			ppm	
Deviation slope	$\Delta F/\Delta Vc$		Monotonic positive				
Modulation BW	MBW			10		Hz	3dB BW

VFTX210

Low Noise TCXO to 1.0 GHz

Sine Wave Output



Electrical Specifications

Parameter	Symbol	Condition	Min	Typ	Max	Unit	Note
Supply Voltage	V _{cc}		3.15	3.30	3.45	V	
Supply Current	I _{cc}	50 Ohm Load		72	85	mA	
Start up time				3		sec	
Phase Jitter	ε	12KHz to 20MHz		0.20	0.35	ps	
SSB Phase Noise	Φ _n	100Hz 1KHz 10KHz 100KHz 1 MHz		-92 -121 -141 -147 -150		dBc/Hz	@ 1000.0 MHz
Setability	F _{nom}				0.1	ppm	
Setability Voltage	V _c		1.2		1.8	V	

How to Order

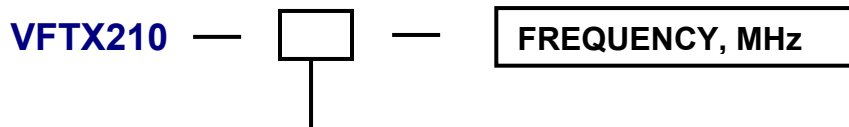

Temperature Range

Code	Specification
B	0°C to 70°C
G	-40°C to 85°C

Absolute Maximum Ratings

Parameter	Symbol	Condition	Min	Typ	Max	Unit	Note
Supply Break Down Voltage	V _{cc}		-0.5		3.6	V	
Storage Temperature	T _s		-55		+105°	°C	
Control Voltage	V _c		-0.5		4.0	V	

VFTX210

Low Noise TCXO to 1.0 GHz

Sine Wave Output



Environmental and Mechanical

Parameter	Specification
Mechanical Shock	Per MIL-STD-202, Method 213, Condition E
Thermal Shock	Per MIL-STD-883, Method 1011, Condition A
Vibration	Per MIL-STD-883, Method 2007, Condition A
Soldering Conditions	260°C for 10s max
Hermetic Seal	Leak rate less than 5×10^{-8} atm.cc/s of helium (crystal only)

Connection Diagram

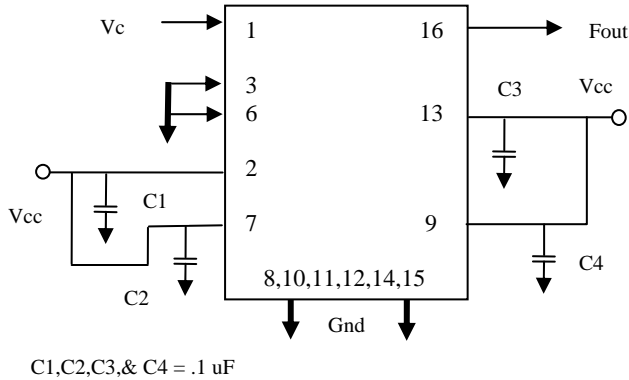

Mechanical Outline

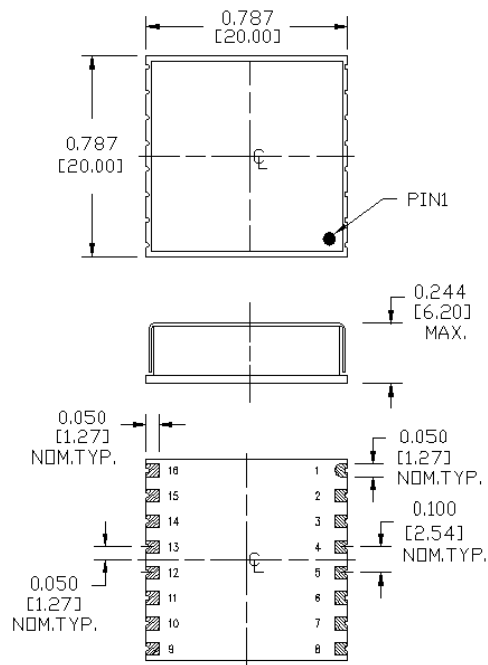

Pin Assignments

Pin #	Description	Pin #	Description
1	Vc	16	Fout
2	Vcc	15	Gnd
3	Gnd	14	Gnd
4	Do Not Connect	13	Vcc
5	Do Not Connect	12	Gnd
6	Gnd	11	Gnd
7	Vcc	10	Gnd
8	Gnd	9	Vcc