

Coaxial

Power Splitter/Combiner

ZFRSC-42+

2 Way-0° Resistive 50Ω DC to 4200 MHz



CASE STYLE: K18

Connectors Model
SMA ZFRSC-42-S+
BRACKET (OPTION "B")

+RoHS Compliant

The +Suffix identifies RoHS Compliance. See our web site for RoHS Compliance methodologies and qualifications

Maximum Ratings

Operating Temperature	-55°C to 100°C
Storage Temperature	-55°C to 100°C
Power Input (as a splitter)	0.75W max.
Internal Dissipation	0.375W max.

Permanent damage may occur if any of these limits are exceeded.

Coaxial Connections

SUM PORT	3
PORT 1	1
PORT 2	2

Outline Drawing

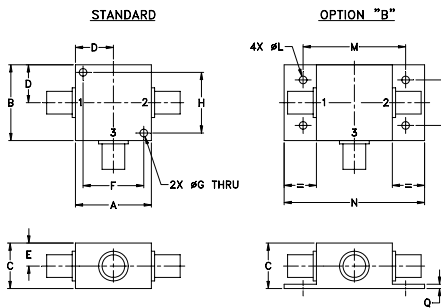

Outline Dimensions (inch/mm)

A	B	C	D	E	F	G	H	J	K	L	M	N	P	Q	wt
1.25	1.25	.75	.63	.38	1.00	.125	1.000	--	--	.125	1.688	2.18	.75	.07	grams
31.75	31.75	19.05	16.00	9.65	25.40	3.18	25.40	--	--	3.18	42.88	55.37	19.05	1.78	70.0

Features

- very wideband, DC to 4200 MHz
- low insertion loss, 0.1 dB typ.
- excellent amplitude unbalance, 0.02 dB typ.
- rugged shielded case

Applications

- laboratory
- test set-ups

Electrical Specifications

FREQ. RANGE (MHz)	ISOLATION (dB)			INSERTION LOSS (dB) ABOVE 6.0 dB						PHASE UNBALANCE (Degrees)			AMPLITUDE UNBALANCE (dB)		
	L	M	U	L		M		U		L	M	U	L	M	U
				Typ.	Max.	Typ.	Max.	Typ.	Max.						
f_L - f_U	Typ.	Typ.	Typ.	Typ.	Max.	Typ.	Max.	Typ.	Max.	Max.	Max.	Max.	Max.	Max.	Max.
DC-4200	6.2	6.5	7.0	0.1	0.2	0.1	0.5	0.4	1.4	1	3	5	0.1	0.2	0.5

L = low range [DC-100 MHz] M = mid range [100 MHz to $f_U/2$] U = upper range [$f_U/2$ to f_U]

This is a resistive power divider to enable frequency coverage from dc to the highest rated frequency. Since resistive power divider do not provide a high degree of isolation (basically isolation equals the insertion loss between ports), an amplifier such as Mini-Circuits' ZFL series is recommended when high isolation is required. Matched power rating 0.75W, internal load dissipation 0.375W.

Typical Performance Data

Frequency (MHz)	Total Loss ¹ (dB)		Amplitude Unbalance (dB)	Isolation (dB)	Phase Unbalance (deg.)	VSWR S	VSWR 1	VSWR 2
	S-1	S-2						
0.05	6.01	6.04	0.03	6.05	0.48	1.00	1.00	1.00
0.50	6.03	6.02	0.01	6.03	0.03	1.00	1.00	1.00
1.00	6.00	6.02	0.02	6.01	0.00	1.00	1.00	1.00
10.00	6.01	6.01	0.00	6.05	0.05	1.00	1.00	1.00
50.00	6.00	6.01	0.01	6.01	0.01	1.00	1.00	1.00
100.00	6.03	6.02	0.01	6.03	0.09	1.00	1.01	1.01
400.00	5.99	6.01	0.02	6.02	0.06	1.01	1.02	1.02
1000.00	5.99	6.02	0.03	5.94	0.63	1.02	1.03	1.03
1400.00	5.97	5.99	0.02	5.94	1.04	1.01	1.03	1.03
2000.00	5.95	5.96	0.01	5.93	1.69	1.03	1.02	1.03
2400.00	6.03	6.01	0.02	5.95	1.96	1.03	1.04	1.04
3000.00	6.12	6.13	0.01	6.06	2.77	1.03	1.07	1.07
3400.00	6.16	6.12	0.04	6.13	3.24	1.02	1.09	1.08
3800.00	6.07	5.99	0.08	6.20	2.70	1.02	1.12	1.10
4200.00	6.12	6.08	0.03	6.18	3.18	1.04	1.14	1.12

1. Total Loss = Insertion Loss + 6dB splitter loss.

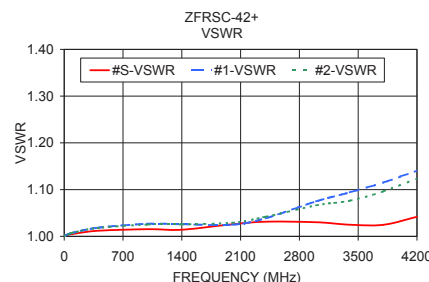
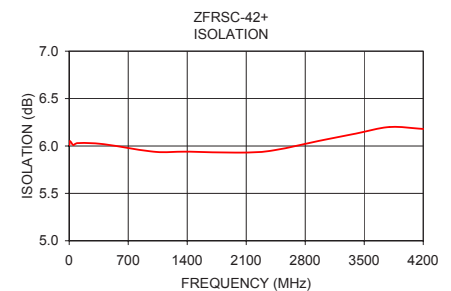
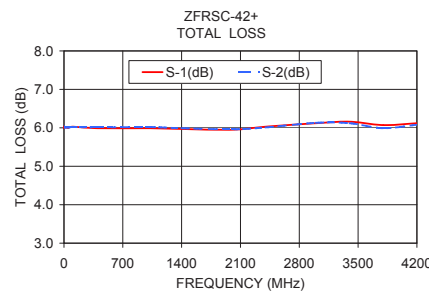

electrical schematic



Notes

- Performance and quality attributes and conditions not expressly stated in this specification document are intended to be excluded and do not form a part of this specification document.
- Electrical specifications and performance data contained in this specification document are based on Mini-Circuit's applicable established test performance criteria and measurement instructions.
- The parts covered by this specification document are subject to Mini-Circuits standard limited warranty and terms and conditions (collectively, "Standard Terms"); Purchasers of this part are entitled to the rights and benefits contained therein. For a full statement of the Standard Terms and the exclusive rights and remedies thereunder, please visit Mini-Circuits' website at www.minicircuits.com/WCLStore/terms.jsp

