

FEATURES

- 2-18 and 2-20 GHz Coverage
- Excellent Phase Noise
- FM/Phase Lock Port
- Excellent Linearity
- High Reliability

DESCRIPTION

The Micro Lambda low noise, extreme wide band Fundamental YIG Tuned Oscillators cover the frequency band of 2-18 and 2-20 GHz. This oscillator series offers SUPERIOR PHASE NOISE performance of -112 dBc/Hz @ 100 kHz offset at 18 GHz and -107 dBc/Hz at 20 GHz. They make ideal local oscillators for synthesizers, receivers, sweep generators and other specialized test equipment.

ELECTRICAL AND PERFORMANCE SPECIFICATIONS

Guaranteed Specifications at 0° to +65° C Case Temperature (Note 1)

Model No.	MLXB-0218	MLXB-0220	MLXS-0218	MLXS-0220
Frequency Range, Min.	2-18 GHz	2-20 GHz	2-18 GHz	2-20 GHz
Power Output, Min.	+13 dBm	+12 dBm	+13 dBm	+12 dBm
Power Output Variation, Max.	+/- 3 dB	+/- 3 dB	+/- 3 dB	+/- 3 dB
Frequency Drift over Temperature, Max.	20 MHz	25 MHz	20 MHz	25 MHz
Pulling Figure (12 dB RL), Typ.	1 MHz	1 MHz	1 MHz	1 MHz
Pushing Figure +15 Vdc Supply, Typ.	0.1 MHz/V	0.1 MHz/V	0.1 MHz/V	0.1 MHz/V
-5 Vdc Supply, Typ.	1 MHz/V	1 MHz/V	1 MHz/V	1 MHz/V
Magnetic Susceptibility @ 60 Hz, Typ.	50 kHz/gauss	50 kHz/gauss	50 kHz/gauss	50 kHz/gauss
2nd Harmonic, Min. @ 25°C	-12 dBc	-12 dBc	-12 dBc	-12 dBc
3rd Harmonic, Min. @ 25°C	-15 dBc	-15 dBc	-15 dBc	-15 dBc
Spurious Output, Min.	-70 dBc	-70 dBc	-70 dBc	-70 dBc
Phase Noise @ 100kHz Offset				
From 2-12 GHz	-120 dBc/Hz	-120 dBc/Hz	-120 dBc/Hz	-120 dBc/Hz
From 12-18 GHz	-112 dBc/Hz	-112 dBc/Hz	-112 dBc/Hz	-112 dBc/Hz
From 18-20 GHz		-107 dBc/Hz		-107 dBc/Hz
Main Coil				
Sensitivity, Typ.	18 MHz/mA	18 MHz/mA	20 MHz/mA	20 MHz/mA
3 dB Bandwidth, Typ.	5 kHz	5 kHz	5 kHz	5 kHz
Linearity, Typ.	+/- 0.1 %	+/- 0.1 %	+/- 0.1 %	+/- 0.1 %
Hysteresis, Typ.	14 MHz	16 MHz	14 MHz	16 MHz
Input Impedance @ 1 kHz, Typ.	7 Ohm /40 mH	7 Ohm /40 mH	6 Ohm /60 mH	6 Ohm /60 mH
FM Coil				
Sensitivity, Typ.	410 kHz/ma	410 kHz/ma	410 kHz/ma	410 kHz/ma
3 dB Bandwidth, Typ.	1 MHz	1 MHz	1 MHz	1 MHz
Deviation @ 400 kHz Rate, Min.	40 MHz	40 MHz	40 MHz	40 MHz
@ 1 MHz Rate, Min.	20 MHz	20 MHz	20 MHz	20 MHz
Input Impedance @ 1 MHz, Typ.	1.0 Ohm / 2uH	1.0 Ohm / 2uH	1.0 Ohm / 2uH	1.0 Ohm / 2uH
DC Circuit Power, +15 Vdc Supply, Max.	100 mA	100 mA	100 mA	100 mA
-5 Vdc Supply, Max.	20 mA	20 mA	20 mA	20 mA
YIG Heater Power				
Input Voltage Range	+24 +/- 4 Vdc	+24 +/- 4 Vdc	+24 +/- 4 Vdc	+24 +/- 4 Vdc
Current Surge/Steady State, Max.	250 mA / 25 mA	250 mA / 25 mA	250 mA / 25 mA	250 mA / 25 mA
Case Style	11-023-1	11-023-1	11-137	11-137

Note: 1. -40 to +85 °C is available.

Outline Drawing: 11-023-1

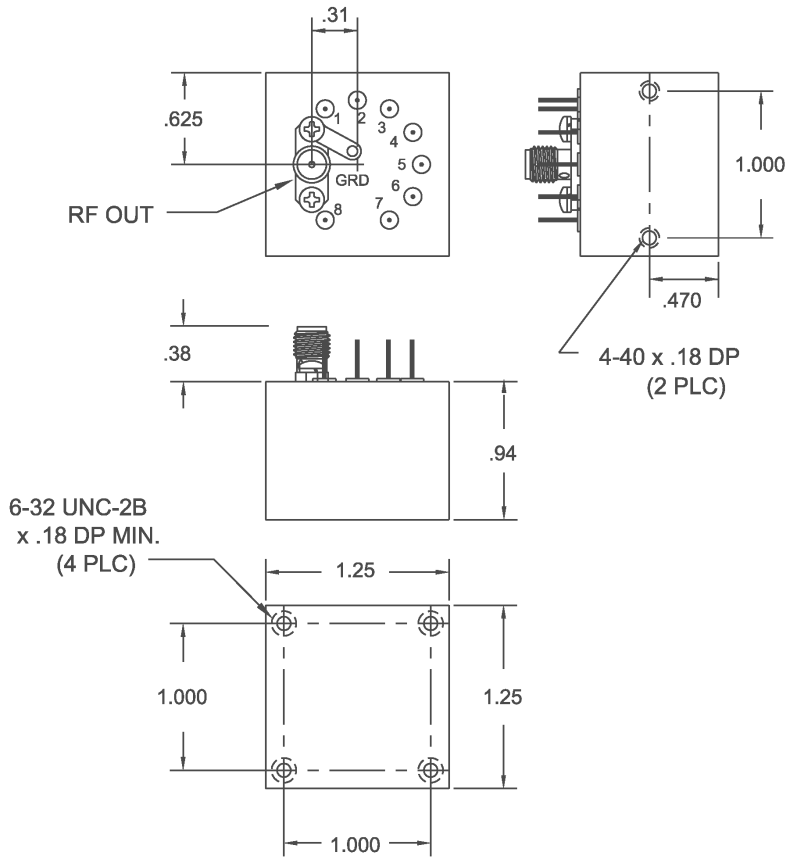

POS	FUNCTION	POS	FUNCTION
1	+ V	5	+ TUNE
2	- 5V	6	- TUNE
3	+ FM	7	HTR
4	- FM	8	HTR

WEIGHT: 8 Oz.

Outline Drawing: 11-137

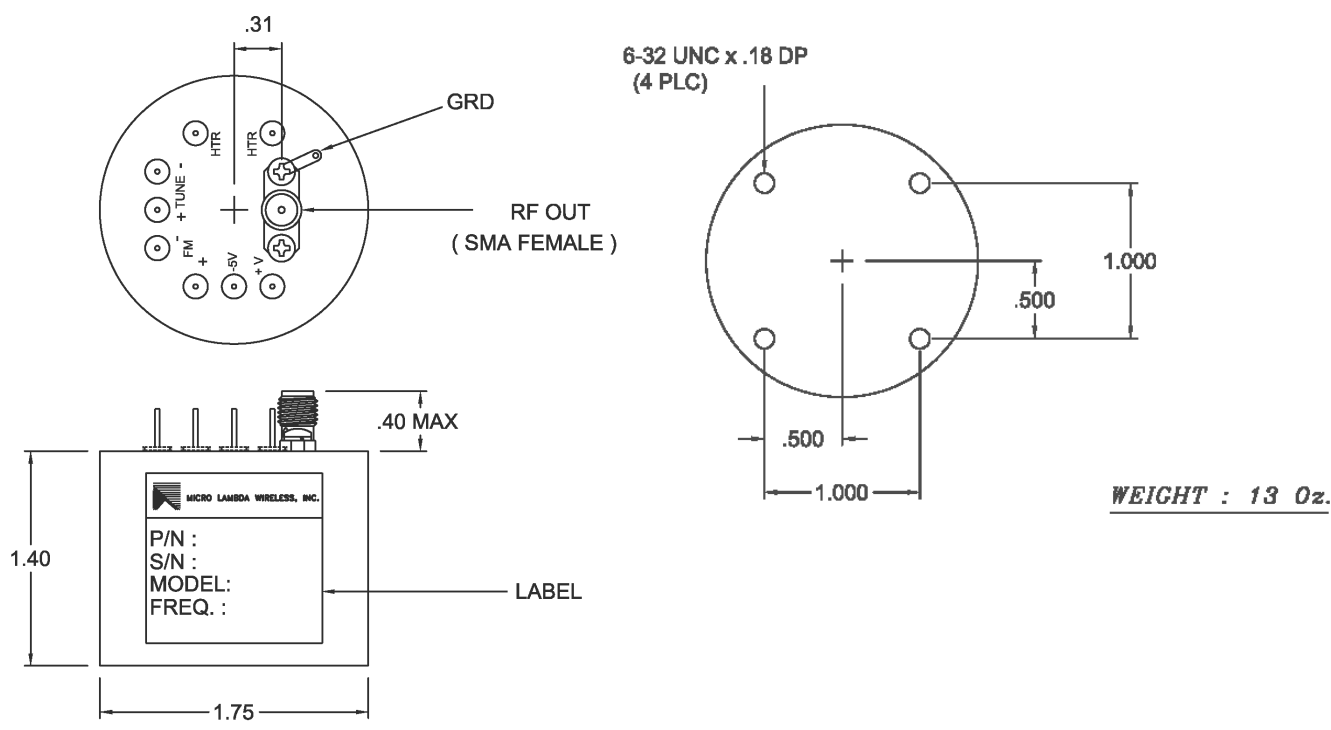

WEIGHT : 13 Oz.