

TITLE: SPECIFICATION CONTROL DRAWING

PART IDENTIFIER: TS05XXW1S
(XX) DB VALUE

DESCRIPTION: CHIP ATTENUATOR

ASSEMBLY DWG: 1900714

1.0 SPECIFICATIONS:

- 1.1 ELECTRICAL:
 - 1.1.1 IMPEDANCE: 50 OHMS NOMINAL.
 - 1.1.2 FREQUENCY RANGE: DC-12.4GHZ.
 - 1.1.3 ATTENUATION VALUES AVAILABLE: 0-20DB IN 1DB INCREMENTS.
 - 1.1.4 ATTENUATION ACCURACY: SEE TABLE.

ATTENUATION ACCURACY			
DB	DC - 4 GHZ	4 - 8 GHZ	8 - 12.4 GHZ
0	-0,+3	-0,+5	-0,+5
1 -3	±0.3	±0.5	±0.5
4 - 6	±0.4	±0.5	±0.5
7 - 10	±0.5	±0.5	±0.75
11 - 15	±0.75	+0.5,-3.0	+0.5,-3.5
16 - 20	±1.0	+0.5,-4.0	+1.0,-6.0

- 1.1.5 VSWR: DC - 4 GHZ - 1.25 MAX 8 - 12.4 GHZ - 1.50 MAX
4 - 8 GHZ - 1.35 MAX
- 1.1.6 INPUT POWER: 100 MILLIWATTS CW.
 - 1.1.6.1 FULL RATED POWER TO 125°C, DERATED LINEARLY TO 0 WATTS AT 150°C.
 - 1.1.6.2 PEAK POWER, 1 WATTS FOR 10US PULSE WIDTH @ 1% DUTY CYCLE.
- 1.2 MECHANICAL:
 - 1.2.1 OUTLINE DWG: SEE SHEET 2.
 - 1.2.2 WORKMANSHIP: PER MIL-PRF-55342.
- 1.3 ENVIRONMENTAL:
 - 1.3.1 ALTITUDE:
 - 1.3.1.1 NON-OPERATING: SEA LEVEL TO 50,000 FEET.
 - 1.3.1.2 OPERATING: SEA LEVEL TO 50,000 FEET.
 - 1.3.2 TEMPERATURE RANGE:
 - 1.3.2.1 NON-OPERATING: -55° C TO +150° C.
 - 1.3.2.2 OPERATING: -55°C TO +150°C.
 - 1.3.3 VIBRATION: PER MIL-STD-202, METHOD 204, COND. D.
 - 1.3.4 SHOCK: PER MIL-STD-202, METHOD 213, COND. I.
 - 1.3.5 MOISTURE RESISTANCE: PER MIL-STD-202, METHOD 106 EXCEPT SUBCYCLE STEPS 7A AND 7B AND POLARIZATION AND LOAD ARE NOT APPLICABLE.

2.0 UNIT MARKING: MARKED ONLY WITH COLOR DOT.
LEGIBILITY AND PERMANENCY PER MIL-STD-130.

3.0 QUALITY ASSURANCE:

- 3.1 SAMPLE INSPECT PER ANSI/ASQC Z1.4 GENERAL INSPECTION, LEVEL II, AQL = 1.0.
 - 3.1.1 VISUAL AND MECHANICAL EXAMINATION FOR CONFORMANCE TO OUTLINE DWG REQUIREMENTS.
- 3.2 PERFORM INSPECTION IN ACCORDANCE WITH QA0006 AND FORM0357 FOR COMMERCIAL GRADE PRODUCT.
- 3.3 TEST DATA REQUIREMENTS:
 - 3.3.1 NO TEST DATA REQUIRED FOR CUSTOMER.
 - 3.3.2 DATA RETENTION – 24 MONTHS.

4.0 PACKAGING: STANDARD PACK PER MC0023.

EMC TECHNOLOGY 8851 SW OLD KANSAS AVE. STUART, FL 34997	CAGE CODE # 24602		DWG #	1007585000
	CHANGE NOTICE	EN 07-E0905	REV LVL	F
			SHEET	1 OF 2

PART ID REF

TS05XXW1S

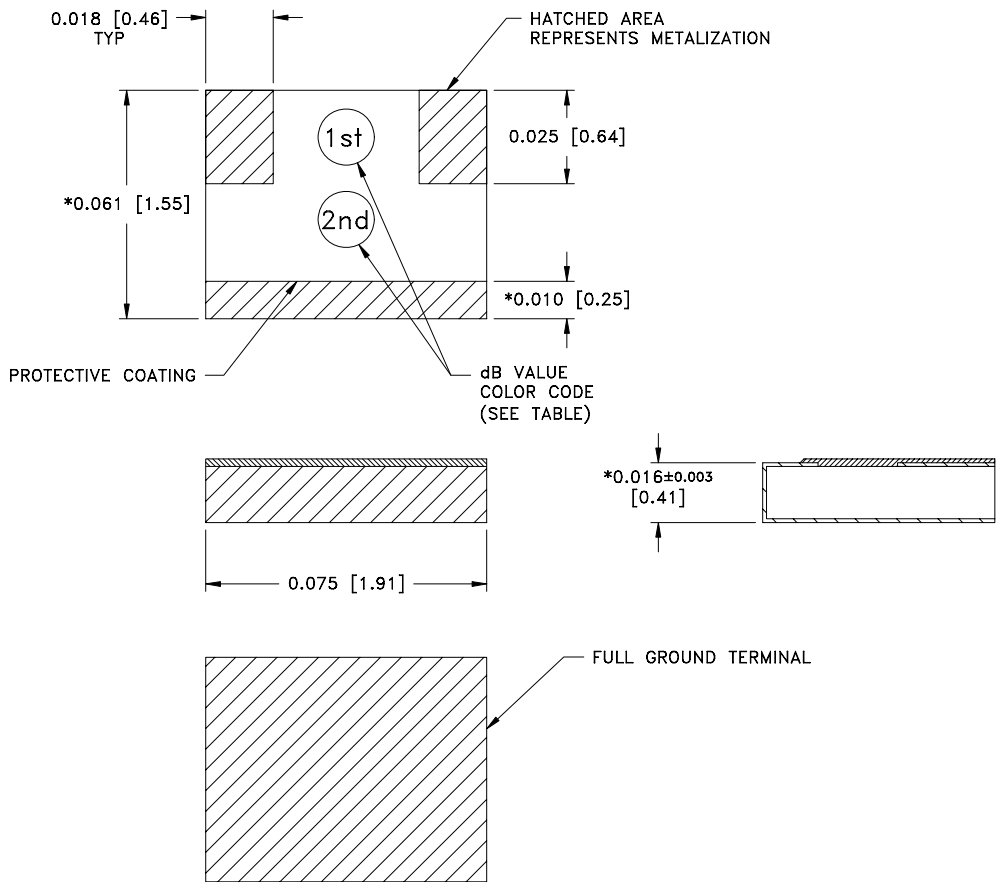

MECHANICAL SPECIFICATIONS:

SUBSTRATE:
 MATERIAL - ALUMINA 96%, MIL-I-10.
 TERMINAL & GROUND PLANE:
 MATERIAL - THICK FILM, NICKEL BARRIER,
 SOLDER COATED.
 RESISTIVE ELEMENT:
 MATERIAL - THIN FILM, TANTALUM NITRIDE.

* DIMENSIONS APPLY BEFORE SOLDER. ALLOW
 0.015 MAX FOR ALL PRETINNED SURFACES.

METRIC EQUIVALENTS GIVEN IN [mm]
 FOR REFERENCE INFORMATION ONLY

POWER RATING AND DERATING

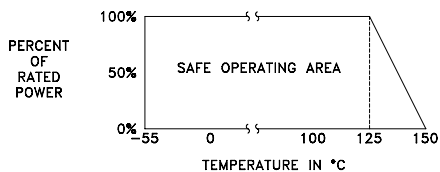

REFERENCE TABLE

dB VAL	DOT COLOR		dB VAL	DOT COLOR	
	1st	2nd		1st	2nd
0	BLK	---	11	BRN	BRN
1	BRN	---	12	BRN	RED
2	RED	---	13	BRN	ORG
3	ORG	---	14	BRN	YEL
4	YEL	---	15	BRN	GRN
5	GRN	---	16	BRN	BLU
6	BLU	---	17	BRN	VIO
7	VIO	---	18	BRN	GRY
8	GRY	---	19	BRN	WHT
9	WHT	---	20	RED	BLK
10	BRN	BLK			



8851 SW OLD KANSAS AVE
 STUART, FL 34997
 PHONE NO. (772)286-9300
 FAX NO. (772)283-5286

UNLESS OTHERWISE SPECIFIED DIMENSIONS ARE IN INCHES

TOLERANCES

FRACT ---
 ANG ---
 XX ---
 XXX ±0.005
 XXXX ---

THESE DRAWINGS AND SPECIFICATIONS ARE THE PROPERTY OF EMC TECHNOLOGY INC AND SHALL NOT BE DUPLICATED OR USED AS BASIS FOR THE MANUFACTURE OR SALE OF PARTS OR DEVICES WITHOUT PERMISSION.

CAGE CODE	SCALE	DRAWN BY	CHECKED BY	APPROVED BY
24602	32:1	JG 9/11/07		DAR 9/11/07
REV	CHANGE NOTICE	DRAWING NO	SHEET	
F	EN 07-E0905	1007585000	2 OF 2	