

- Precision UHF SAW Filter
- 5.0 x 5.0 mm Surface-mount Case
- Single-ended Input and Output
- Complies with Directive 2002/95/EC (RoHS)



Absolute Maximum Ratings

Rating	Value	Units
Maximum Incident Power in Passband	+13	dBm
Maximum DC Voltage on any Non-ground Terminal	30	VDC
Storage Temperature Range in Tape and Reel	-40 to +85	°C
Suitable for Lead-free Soldering - Maximum Soldering Temperature	260 °C for 30 s	

SF2090C

**357.50 MHz
SAW Filter**

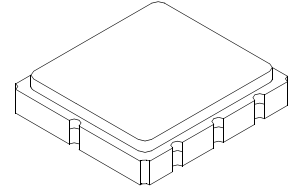

SM5050-8

Electrical Characteristics

Characteristic	Sym	Notes	Min	Typ	Max	Units
Nominal Center Frequency	f_C	1		357.5		MHz
Insertion Loss		1			12	dB
1.5 dB Bandwidth	$BW_{1.5\text{ dB}}$	1	35			MHz
Amplitude Ripple, $f_C \pm 17.5$ MHz, within adjacent 5 MHz Windows		1			1.0	dB _{P-P}
Group Delay Deviation, $f_C \pm 17.5$ MHz, within adjacent 5 MHz Windows		1			55	ns _{P-P}
VSWR at f_C		1			2.5:1	
Group Delay Deviation, $f_C \pm 15$ MHz		1		100	180	ns _{P-P}
40 dB Rejection Bandwidth		1, 2			65	MHz
Operating Temperature Range			-40		85	°C
Case Style			SM5050-8 5 x 5 mm Nominal Footprint			
Lid Symbolization (Y=year, WW=week, S=shift)			RFM 592 YWWS			

Electrical Connections

Connection		Terminals
Port 1	Input	1
Port 2	Output	5
	Ground	All others

Dot indicates Pin 1



CAUTION: Electrostatic Sensitive Device. Observe precautions for handling.

NOTES:

1. Unless noted otherwise, all specifications apply over the operating temperature range with filter soldered to the specified demonstration board with impedance matching to 50 Ω and measured with 50 Ω network analyzer.
2. Rejection is measured as attenuation below the minimum IL point in the passband. Rejection in final user application is dependent on PCB layout and external impedance matching design. See Application Note No. 42 for details.
3. The design, manufacturing process, and specifications of this filter are subject to change.
4. Tape and Reel Standard ANSI / EIA 481.
5. Either Port 1 or Port 2 may be used for either input or output in the design. However, impedances and impedance matching may vary between Port 1 and Port 2, so that the filter must always be installed in one direction per the circuit design.
6. US and international patents may apply.
7. Murata, stylized Murata logo, and Murata N.A., Inc. are registered trademarks of Murata Manufacturing Co., Ltd.

18 Nov 2005 15:46:55

CH1 S11 1 U FS
 1: 19.778 mS -11.043 mS 41.928 nH
 343.750 000 MHz

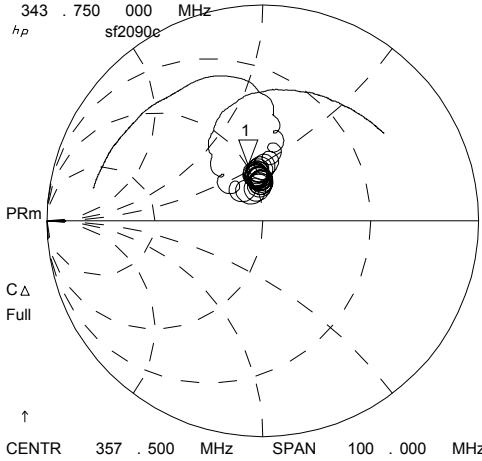

CH3 S22 1 U FS
 1: 27.676 mS -6.7959 mS 68.129 nH
 343.750 000 MHz

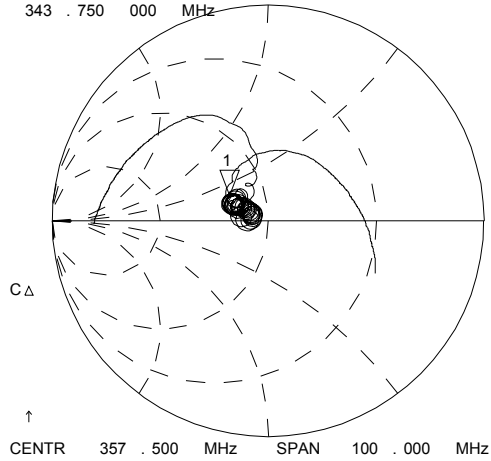

CH2 S21 LOG 10 dB/ REF -12 dB 1: 0.0000 dB 0.000 000 MHz

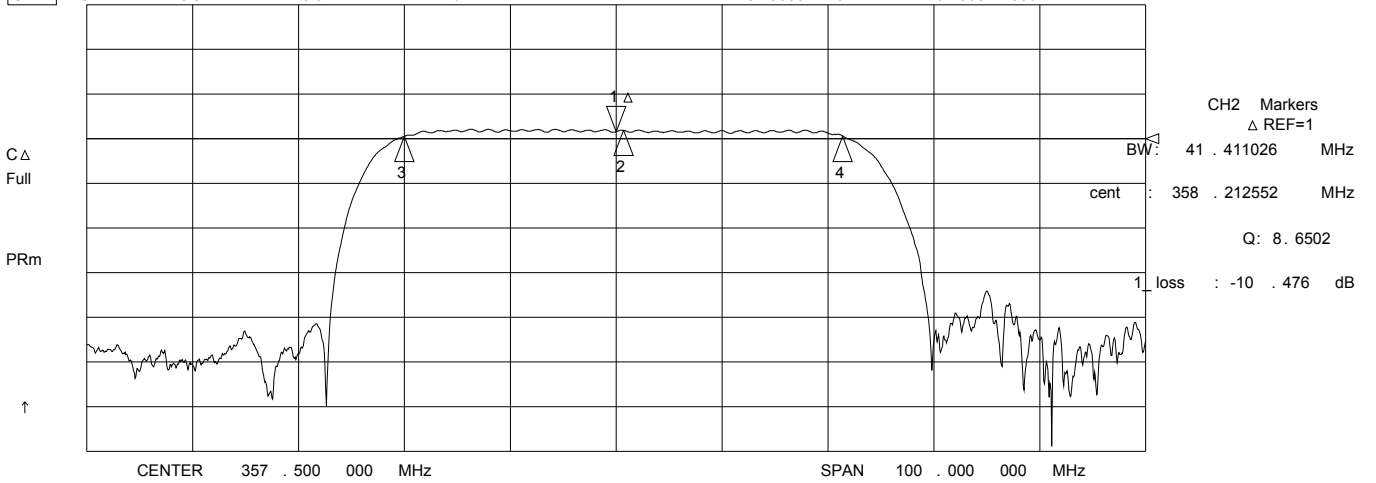

18 Nov 2005 15:49:59

CH2 S21 LOG 1 dB/ REF -12 dB 3 : -12860 dB -30 .000 000 MHz

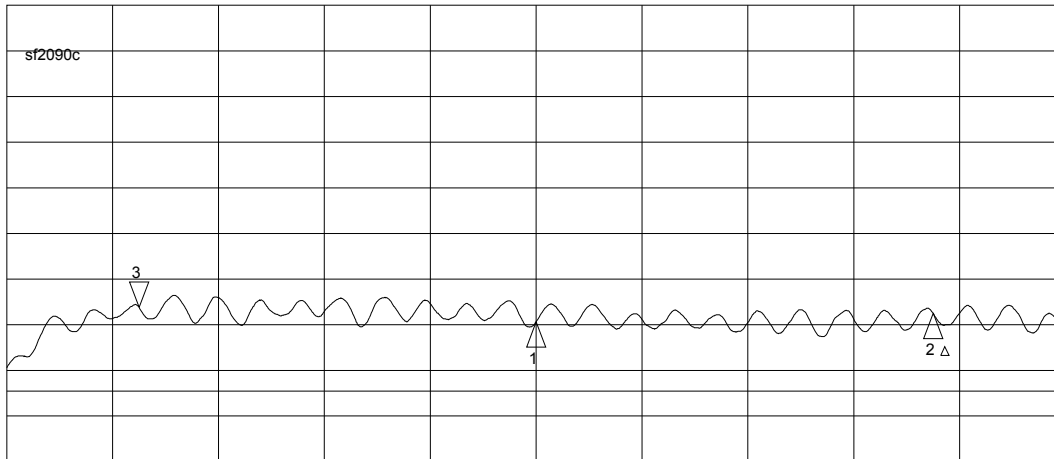

CH2 Markers
Δ REF=2
mean : -10 .339 dB
s. dev : .20600 dB
p-p : .90850 dB

CH4 S21 DEL 50 ns/ REF 358.5 ns 3 : -2 .3651 ns -30 .000 000 MHz

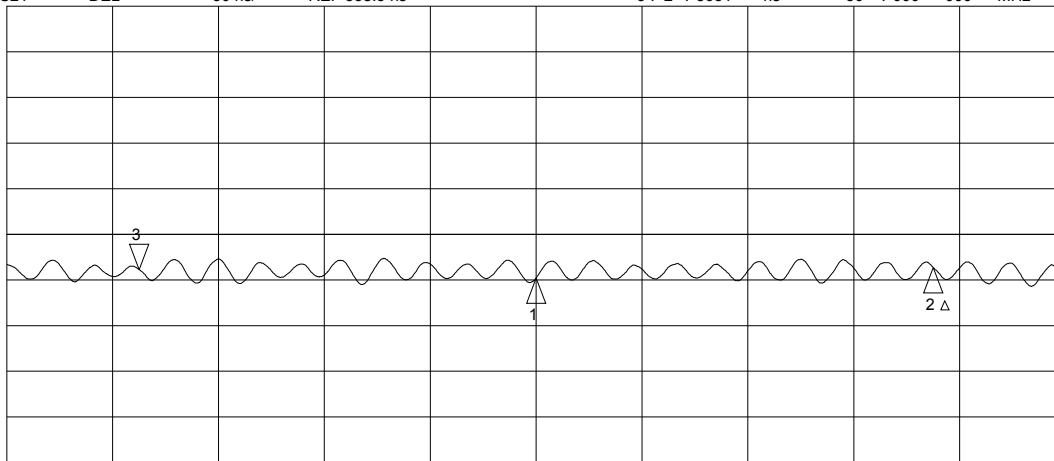

CH4 Markers
Δ REF=2
mean : 318 .43 ns
s. dev : 7 .4471 ns
p-p : 28 .639 ns

CENTER 357 .500 000 MHz SPAN 40 .000 000 MHz

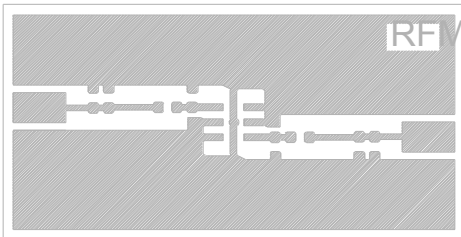
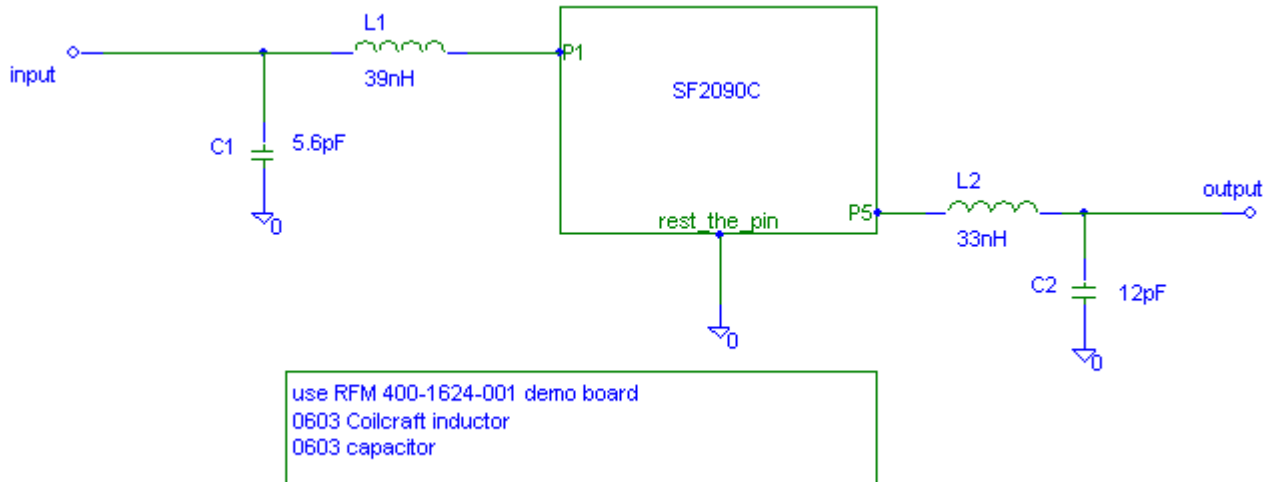

1.590 REF.

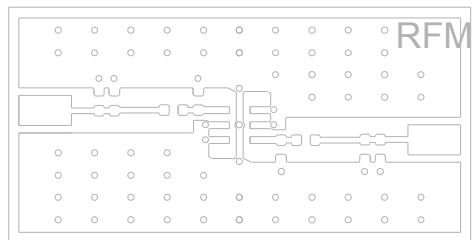

DRILL ALL HOLES #76 DRILL (0.020)
ALL HOLES ARE PLATED THRU.

SM5050-8 Surface-Mount 8-Terminal Ceramic Case 5.0 X 5.0 mm Nominal Footprint

Case Dimensions

Dimension	mm			Inches		
	Min	Nom	Max	Min	Nom	Max
A	4.80	5.00	5.20	0.189	0.197	0.205
B	4.80	5.00	5.20	0.189	0.197	0.205
C	1.30	1.50	1.70	0.050	0.060	0.067
D	1.98	2.08	2.18	0.078	0.082	0.086
E	1.07	1.17	1.27	0.042	0.046	0.050
F	0.50	0.64	0.70	0.020	0.025	0.028
G	2.39	2.54	2.69	0.094	0.100	0.106
H		1.27			0.050	
I		0.76			0.030	
J		1.55			0.061	
K		2.79			0.110	
L		0.76			0.030	
M		2.36			0.093	
N		1.55			0.061	
O		2.79			0.110	
P		2.79			0.110	
Q		2.79			0.110	

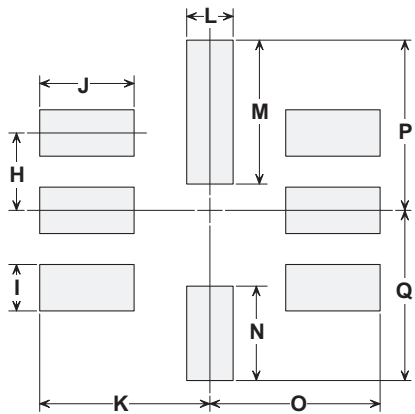
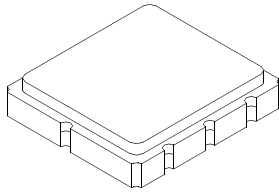

PCB Footprint

Case Materials

Materials	
Solder Pad Plating	0.3 to 1.0 μm Gold over 1.27 to 8.89 μm Nickel
Lid Plating	2.0 to 3.0 μm Nickel
Body	Al_2O_3 Ceramic
	Pb Free

TOP VIEW

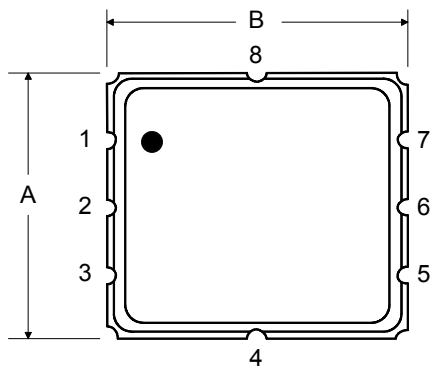

BOTTOM VIEW

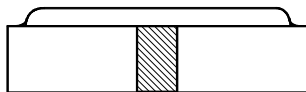
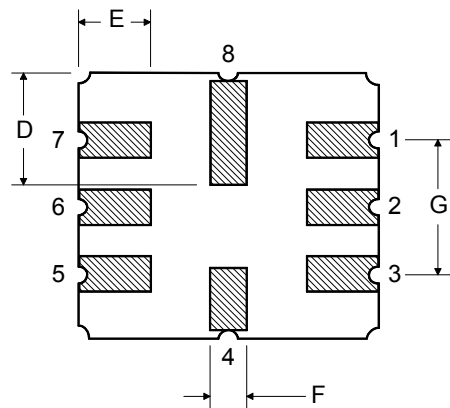

Tape and Reel Specifications

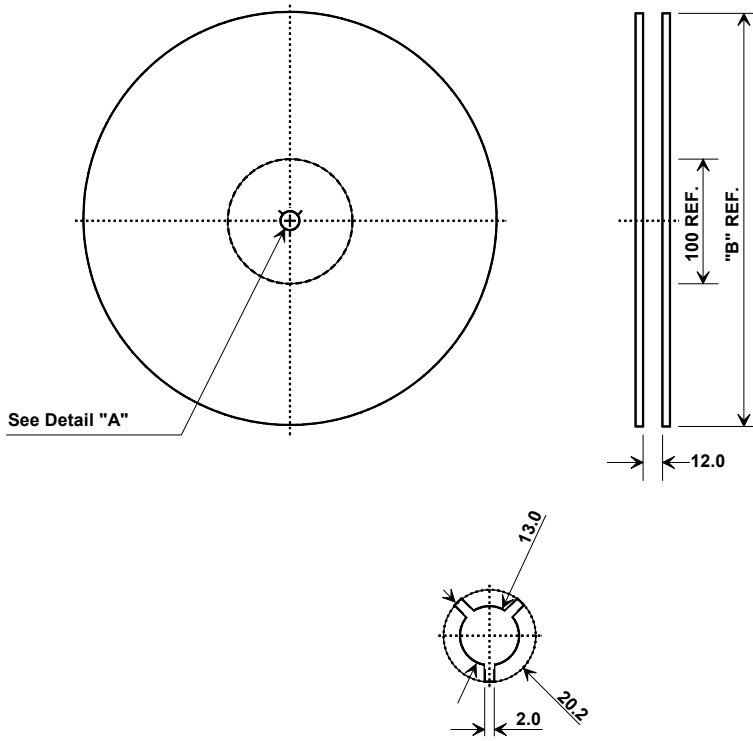

"B" Nominal Size		Quantity Per Reel
Inches	millimeters	
7	178	500
13	330	3000

COMPONENT ORIENTATION and DIMENSIONS

Carrier Tape Dimensions	
Ao	5.3 mm
Bo	5.3 mm
Ko	2.0 mm
Pitch	8.0 mm
W	12.0 mm

