

TITLE: SPECIFICATION CONTROL DRAWING

PART IDENTIFIER: TS02XXW3
(XX) DB VALUE

DESCRIPTION: HIGH POWER ATTENUATOR

ASSEMBLY DWG: 1901794

1.0 SPECIFICATIONS:

- 1.1 ELECTRICAL:
 - 1.1.1 IMPEDANCE: 50Ω NOMINAL.
 - 1.1.2 FREQUENCY RANGE: DC-2.5 GHZ.
 - 1.1.3 ATTENUATION VALUES AVAILABLE: 0-10DB.
 - 1.1.4 ATTENUATION ACCURACY @ 960 MHZ: 0 - 10 DB, ±0.5 DB; @ 2.5 GHZ, +0, -1.0 DB.
 - 1.1.5 INPUT POWER: 4 WATTS CW.
 - 1.1.5.1 FULL RATED POWER TO 100°C, DERATED LINEARLY TO 0 WATTS AT 150°C.
 - 1.1.6 VSWR: 1.15 MAX @ 960 MHZ; 1.50 MAX @ 2.5 GHZ.
- 1.2 MECHANICAL:
 - 1.2.1 OUTLINE DWG: SEE SHEET 2.
 - 1.2.2 WORKMANSHIP: PER MIL-STD-454, REQUIREMENT 9, AND MIL-R-55342.
- 1.3 ENVIRONMENTAL:
 - 1.3.1 TEMPERATURE RANGE:
 - 1.3.1.1 STORAGE: -65°C TO +150°C.
 - 1.3.1.2 OPERATING: -55°C TO +150°C.

2.0 UNIT MARKING: DB VALUE.
LEGIBILITY AND PERMANENCY PER MIL-STD-130.

3.0 QUALITY ASSURANCE:

- 3.1 SAMPLE INSPECT PER ANSI/ASQC Z1.4, GENERAL INSPECTION, LEVEL II, AQL=1.0.
 - 3.1.1 VISUAL AND MECHANICAL EXAMINATION FOR CONFORMANCE TO OUTLINE DWG REQUIREMENTS.
- 3.2 PERFORM INSPECTION IN ACCORDANCE WITH 824W170 AND 824F036 FOR COMMERCIAL GRADE PRODUCT.
- 3.3 DATA REQUIREMENTS:
 - 3.3.1 NO TEST DATA REQUIRED FOR CUSTOMER.
 - 3.3.2 DATA RETENTION - STANDARD.

4.0 PACKAGING: STANDARD PACK PER 755W002.

EMC TECHNOLOGY 8851 SW OLD KANSAS AVE. STUART, FL 34997	CAGE CODE # 24602		DWG #	1010945000
	CHANGE NOTICE	EN 12-0265	REV LVL	B
			SHEET	1 OF 2

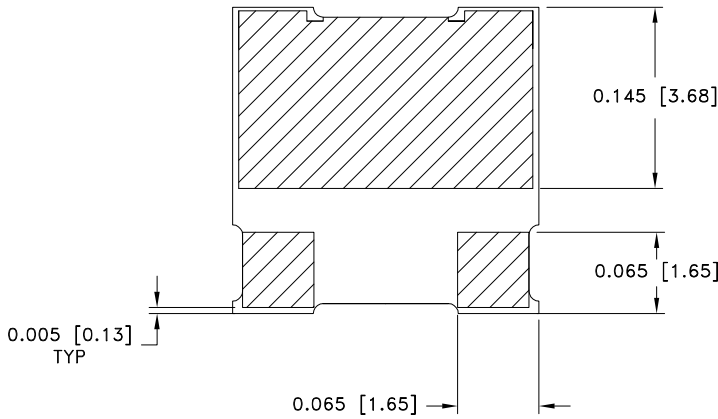
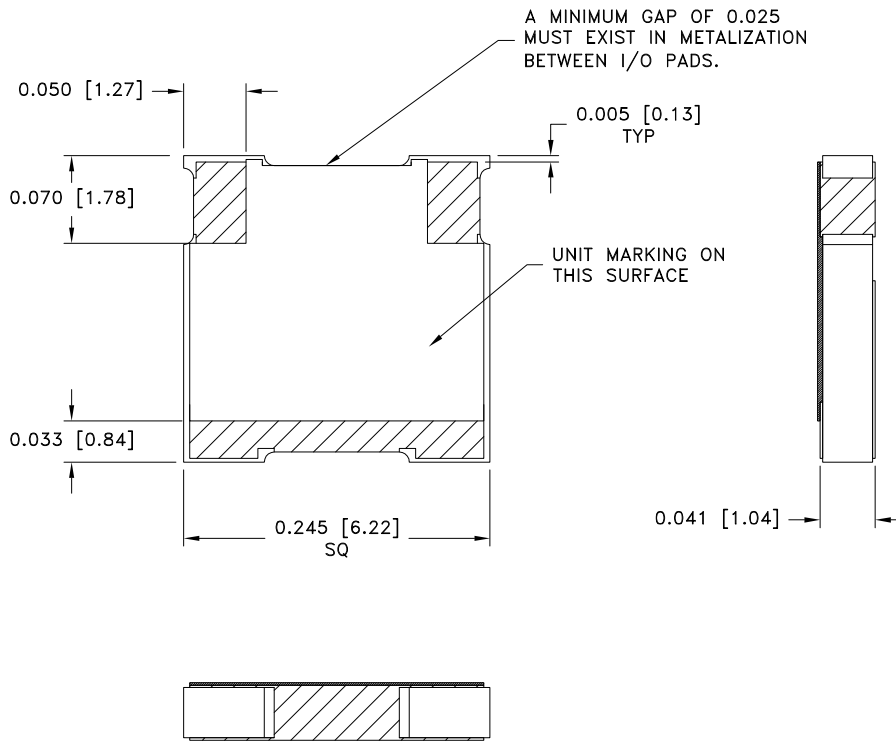

MECHANICAL SPECIFICATIONS:

SUBSTRATE:
 MATERIAL - ALUMINA, 96%, MIL-I-10.
 TERMINAL:
 MATERIAL - THICK FILM, NICKEL BARRIER,
 SOLDER PLATED.
 RESISTIVE ELEMENT:
 MATERIAL - THICK FILM.

METRIC EQUIVALENTS GIVEN IN [mm]
 FOR REFERENCE INFORMATION ONLY

 8851 SW OLD KANSAS AVE STUART, FL 34997 PHONE NO. (772)286-9300 FAX NO. (772)283-5286	UNLESS OTHERWISE SPECIFIED DIMENSIONS ARE IN INCHES TOLERANCES FRACT --- -- ANG --- -- XX --- -- XXX ±0.005 XXXX --- --	THESE DRAWINGS AND SPECIFICATIONS ARE THE PROPERTY OF EMC TECHNOLOGY INC AND SHALL NOT BE DUPLICATED OR USED AS BASIS FOR THE MANUFACTURE OR SALE OF PARTS OR DEVICES WITHOUT PERMISSION.					
		CAGE CODE	SCALE	DRAWN BY	CHECKED BY	APPROVED BY	
		24602	N/A	JG 9/13/05		DAR 9/13/05	
		REV	CHANGE NOTICE	DRAWING NO	SHEET		
	B	EN 12-0265	1010945000	2	OF 2		