

TITLE: SPECIFICATION CONTROL DRAWING

PART IDENTIFIER: TS09XXWB2
(XX) = DB VALUE

DESCRIPTION: FIXED VALUE CHIP ATTENUATOR, ROHS COMPLIANT.

ASSEMBLY DWG: 1902444

1.0 SPECIFICATIONS:

1.1 ELECTRICAL:

- 1.1.1 IMPEDANCE: 50 OHMS NOMINAL.
- 1.1.2 OPERATING FREQUENCY RANGE: DC – 20 GHZ.
- 1.1.3 ATTENUATION VALUES AVAILABLE: 1-10dB.
- 1.1.4 ATTENUATION ACCURACY AT 25°C:
0-4 dB DC-20 GHz ± 0.5 dB
5-10 dB DC-15 GHz ± 0.5 dB
15-20 GHz ± 0.75 dB
- 1.1.5 VSWR: DC-10 GHz 1.25:1 MAX
10-20 GHz 1.45:1 MAX
- 1.1.6 INPUT POWER: 200 MILLIWATTS CW.
1.1.6.1 FULL RATED POWER TO 125°C, DERATED LINEARLY TO 0 WATTS AT 150°C.

1.2 MECHANICAL:

- 1.2.1 OUTLINE DWG: SEE SHEET 2.
- 1.2.2 WORKMANSHIP: PER MIL-PRF-55342.

1.3 ENVIRONMENTAL:

- 1.3.1 OPERATING TEMPERATURE RANGE: -55°C TO +150°C

2.0 UNIT MARKING: NONE

3.0 QUALITY ASSURANCE:

- 3.1 SAMPLE INSPECT PER ANSI/ASQC Z1.4 GENERAL INSPECTION, LEVEL II, AQL = 1.0.
 - 3.1.1 VISUAL AND MECHANICAL EXAMINATION FOR CONFORMANCE TO OUTLINE DRAWING REQUIREMENTS.
- 3.2 INSPECTION IN ACCORDANCE WITH 824W170 AND 824F036 FOR COMMERCIAL GRADE PRODUCT.
- 3.3 TEST DATA REQUIREMENTS:
 - 3.4.1 NO TEST DATA REQUIRED FOR CUSTOMER.
 - 3.4.2 DATA RETENTION - 24 MONTHS.

4.0 PACKAGING: STANDARD PACK PER 755W002.

EMC TECHNOLOGY 8851 SW OLD KANSAS AVE. STUART, FL 34997	CAGE CODE # 24602		DWG #	1012675000
	CHANGE NOTICE	EN 11-1356	REV LVL	-
			SHEET	1 OF 2

PART ID REF

TS09XXWB2

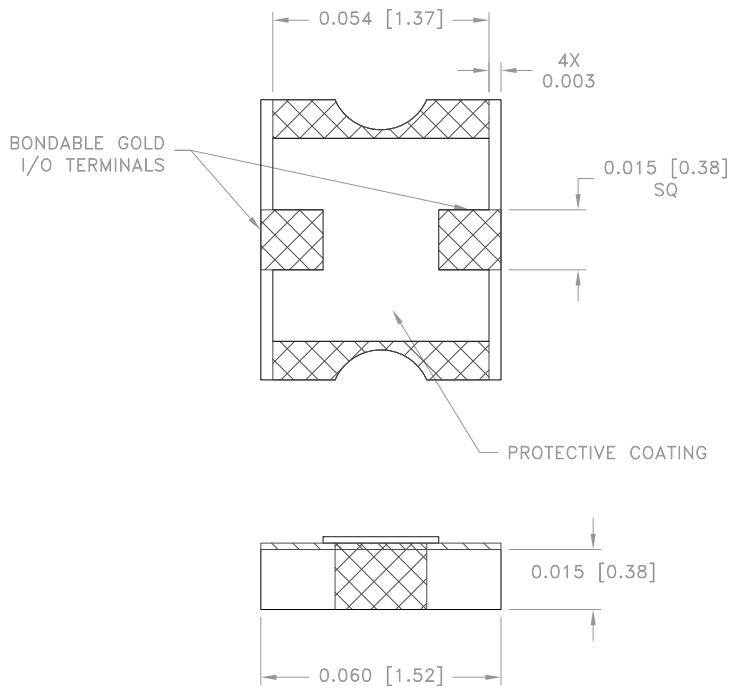

INSULATED GAP IS FOR MANUFACTURING PURPOSES. GROUNDS SHOULD BE ELECTRICALLY SHORTED DURING ATTACHMENT.

GROUND TERMINALS

MECHANICAL SPECIFICATIONS:

SUBSTRATE:
 MATERIAL - ALUMINA 96%, MIL-I-10.
 TERMINAL:
 MATERIAL - THICK FILM, BONDABLE GOLD.
 GROUND PLANE:
 MATERIAL - THICK FILM, SOLDERABLE.
 RESISTIVE ELEMENT:
 MATERIAL - THICK FILM.

METRIC EQUIVALENTS GIVEN IN [mm]
 FOR REFERENCE INFORMATION ONLY

POWER RATING AND DERATING

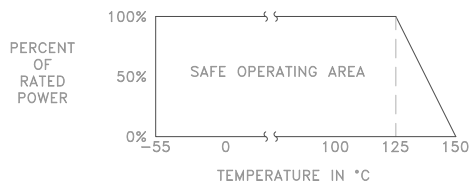

8851 SW OLD KANSAS AVE
 STUART, FL 34997
 PHONE NO. (772)286-9300
 FAX NO. (772)283-5286

UNLESS OTHERWISE SPECIFIED DIMENSIONS ARE IN INCHES

TOLERANCES

FRACT --- --
 ANG --- --
 XX --- --
 XXX ±0.005
 XXXX --- --

THESE DRAWINGS AND SPECIFICATIONS ARE THE PROPERTY OF EMC TECHNOLOGY INC AND SHALL NOT BE DUPLICATED OR USED AS BASIS FOR THE MANUFACTURE OR SALE OF PARTS OR DEVICES WITHOUT PERMISSION.

CAGE CODE	SCALE	DRAWN BY	CHECKED BY	APPROVED BY
24602	N/A	SP 12/13/11		
REV	CHANGE NOTICE	DRAWING NO	SHEET	
-	EN 11-1356	1012675000	2 OF 2	