

AWG0115 Data Sheet

30 ~ 4000 MHz Wide-band Gain Block Amplifier MMIC

1. Product Overview

1.1 General Description

AWG0115, a gain block amplifier MMIC, has high linearity, low noise and high efficiency over a wide range of frequency from 30 MHz to 4000 MHz, being suitable for use in both receiver and transmitter of telecommunication system up to 4 GHz. It has an active bias network for stable current over temperature and process variation. The amplifier is available in an SOT363 package and passes through the stringent DC, RF, and reliability tests.

1.2 Features

- 14.3 dB gain at 2000 MHz
- 16.0 dBm P1dB at 2000 MHz
- 34.0 dBm OIP3 at 2000 MHz
- Gain flatness = 0.8 dB at 500 ~ 2500 MHz
- 50 Ω input & output matching
- MTTF > 100 Years
- Single supply: +3 V

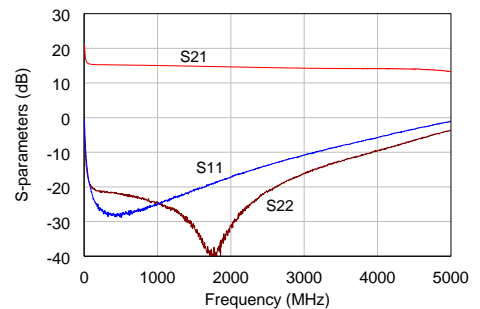

Gain & Return Loss vs. Frequency (with Bias Tees)



1.3 Applications

- Wide-band application at 500 ~ 3000 MHz
- IF, CATV application at 30 ~ 1200 MHz
- SMATV, ONU application at 50 ~ 3000 MHz

1.4 Package Profile & RoHS Compliance

 <p>SOT363, 2.1x2.0 mm², surface mount</p>	 <p>RoHS-compliant</p>
--	---

2. Summary on Product Performances

2.1 Typical Performance

Supply voltage = +3 V, T_A = +25 °C, Z_O = 50 Ω.

Parameter	Typical								Unit
Frequency	70	150	300	450	900	2000	2500	2700	MHz
Gain	15.4	15.2	15.1	15.1	14.8	14.3	14.0	13.9	dB
S11	-18.0	-20.0	-20.0	-20.0	-20.0	-20.0	-20.0	-20.0	dB
S22	-18.0	-18.0	-20.0	-20.0	-14.0	-18.0	-20.0	-20.0	dB
Noise Figure	2.3	2.3	2.3	2.3	2.3	2.7	3.0	3.3	dB
Output IP3 ¹⁾	32.0	33.0	34.0	33.0	34.0	34.0	29.0	28.0	dBm
Output P1dB	16.0	16.0	16.0	16.0	16.0	16.0	15.0	15.0	dBm
Current	57								
Device Voltage	+3								

1) OIP3 is measured with two tones at an output power of +0 dBm/tone separated by 1MHz.

2.2 Product Specification

Supply voltage = +3 V, T_A = +25 °C, Z_O = 50 Ω.

Parameter	Min	Typ	Max	Unit
Frequency		2000		MHz
Gain		14.3		dB
S11		-20.0		dB
S22		-18.0		dB
Noise Figure		2.7		dB
OIP3		34.0		dBm
P1dB		16.0		dBm
Current		57		mA
Device Voltage		+3		V

2.3 Pin Configuration

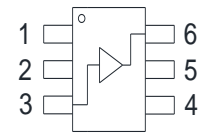
Pin	Description	Simplified Outline
1, 2, 4, 5	Ground	
3	RF_INPUT	
6	RF_OUT & Bias	

2.4 Absolute Maximum Ratings

Parameters	Max. Ratings
Operation Case Temperature	-40 to +85 °C
Storage Temperature	-40 to +150 °C
Device Voltage	+4 V
Operation Junction Temperature	+150 °C
Input RF Power (At 2000 MHz, CW, 50 Ω matched)*	+ 27 dBm

*Please find the max. input power data from http://www.asb.co.kr/pdf/Maximum_Input_Power_Analysis.pdf
 The max. input power, in principle, depends upon the application frequency and matching circuit.

2.5 Thermal Resistance

Symbol	Description	Typ	Unit
R _{th}	Thermal resistance from junction to lead	160	°C/W

2.6 ESD Classification & Moisture Sensitivity Level

ESD Classification

HBM	Class 1B	Voltage Level: 750 V
MM	Class A	Voltage Level: 100 V

CAUTION: Gallium Arsenide Integrated Circuits are sensitive to electrostatic discharge (ESD) and can be damaged by static electricity. Proper ESD control techniques should be used when handling these devices.

Moisture Sensitivity Level

MSL 3 at 260 °C reflow

(Intentionally Blanked)

3. Application: 500 ~ 3000 MHz

3.1 Application Circuit & Evaluation Board

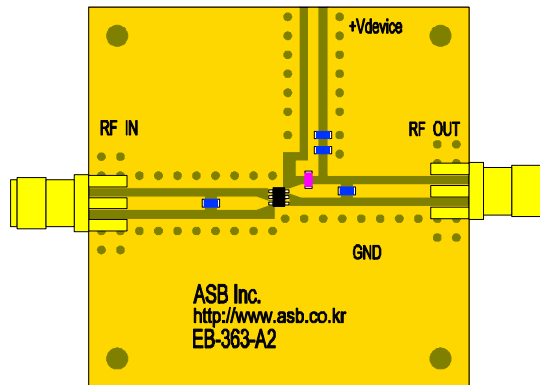
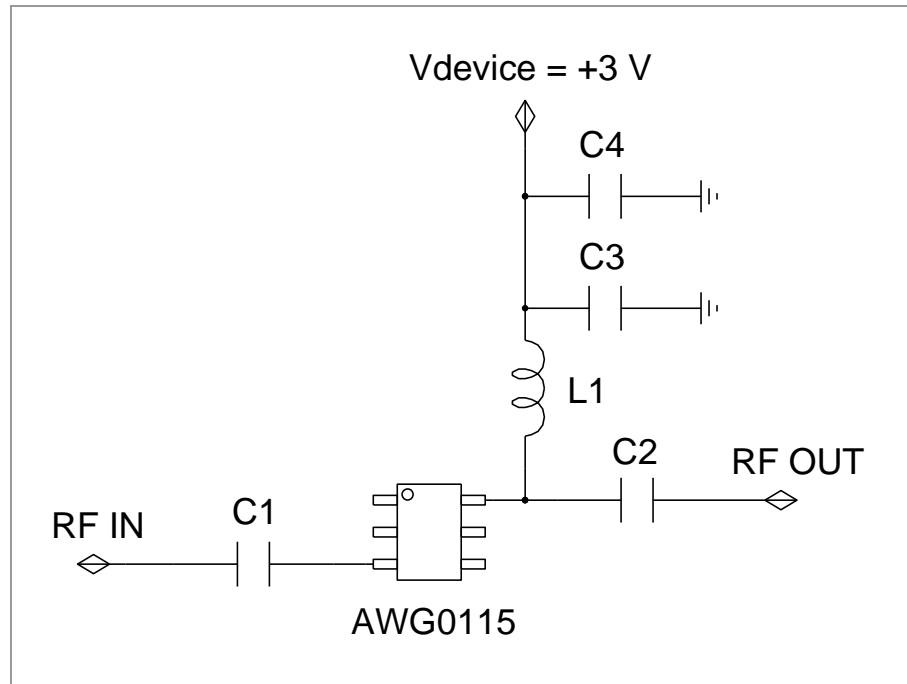

PCB Information	
Material	FR4
Thickness (mm)	0.8
Size (mm)	40x40
EB No.	EB-363-A2

Bill of Material

Symbol	Value	Size	Description	Manufacturer
AWG0115	-	-	MMIC Amplifier	ASB
C1, C2, C3	100 pF	0603	DC blocking capacitor	Murata
C4	1 μ F	0603	Decoupling capacitor	Murata
L1	33 nH	0603	RF choke inductor	Murata

3.2 Performance Table

Supply voltage = +3 V, T_A = +25 °C, Z₀ = 50 Ω.

Parameter	Typical						Unit
Frequency	500	900	2000	2500	2700	3000	MHz
Gain	14.8	14.8	14.3	14.0	13.9	13.9	dB
S11	-15.0	-20.0	-20.0	-20.0	-20.0	-18.0	dB
S22	-11.0	-14.0	-18.0	-20.0	-20.0	-20.0	dB
Noise Figure	2.3	2.3	2.7	3.0	3.3	3.6	dB
Output IP3 ¹⁾	34.0	34.0	34.0	29.0	28.0	23.0	dBm
Output P1dB	16.0	16.0	16.0	15.0	15.0	14.0	dBm
Current	57						mA
Device Voltage	+3						V

1) OIP3 is measured with two tones at an output power of +0 dBm/tone separated by 1MHz.

3.3 Plot of S-parameter & Stability Factor

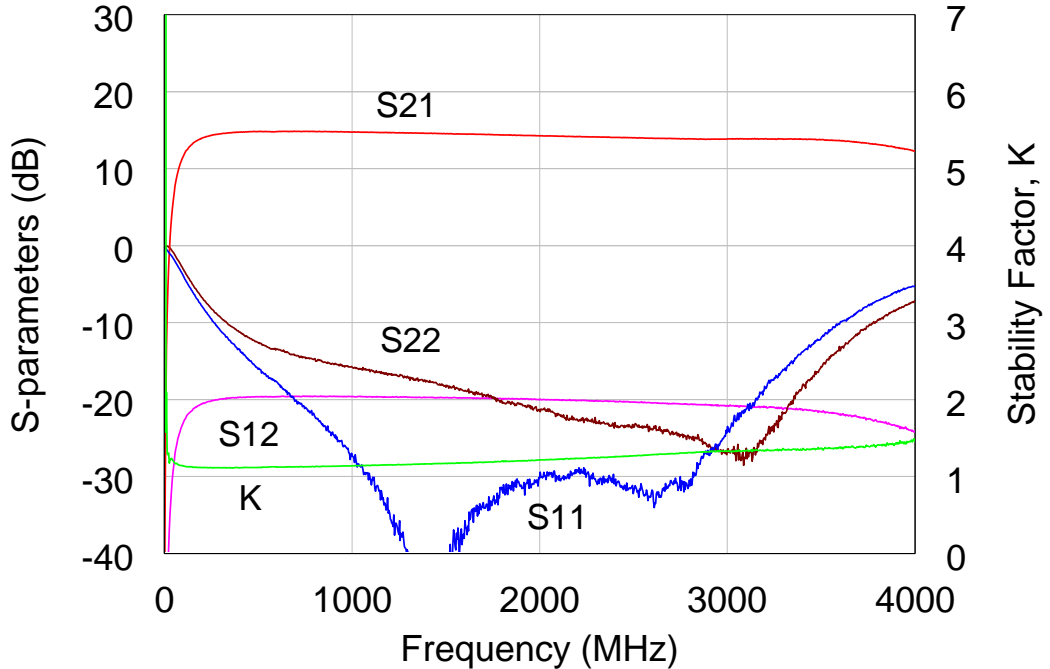

3.4 Plots of Noise Figure and Performances with Temperature

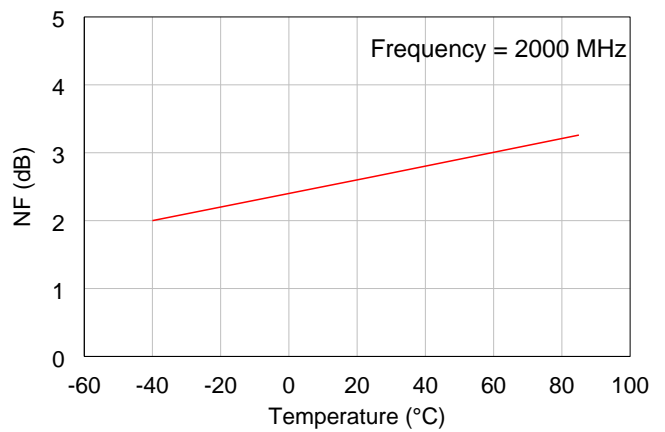
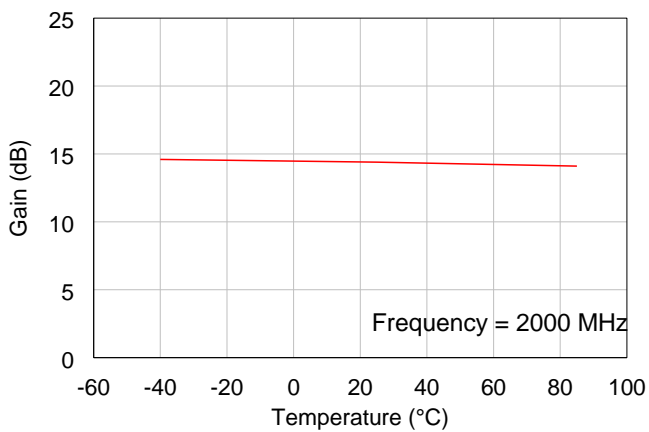
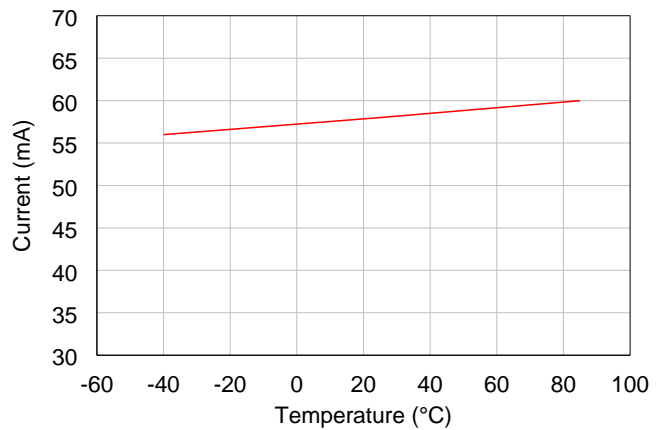
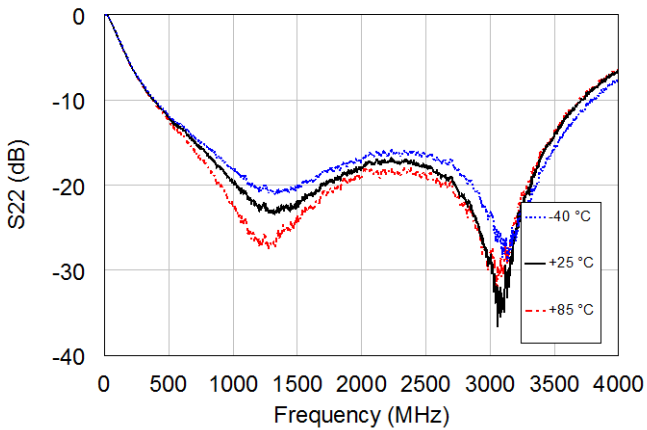
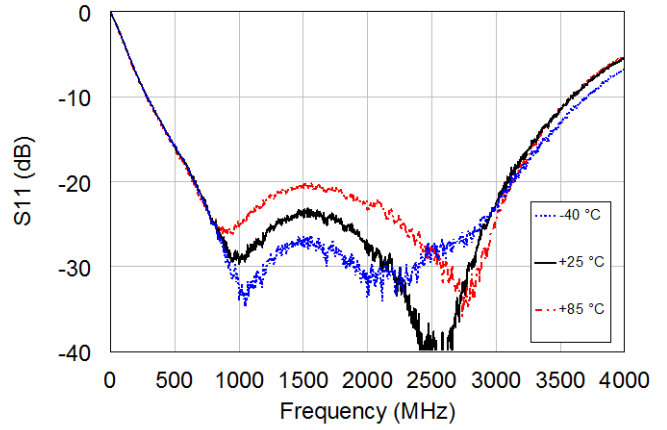
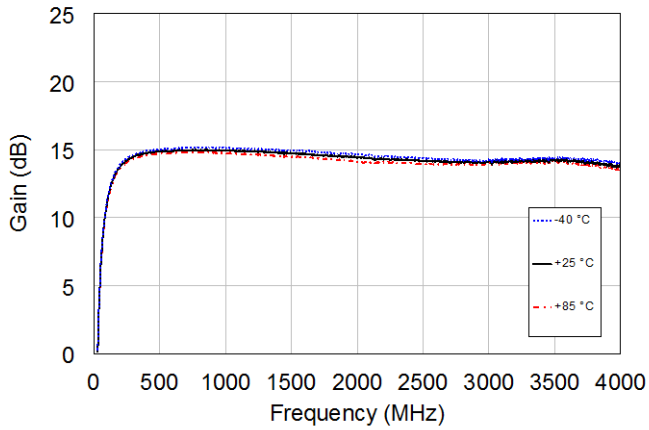

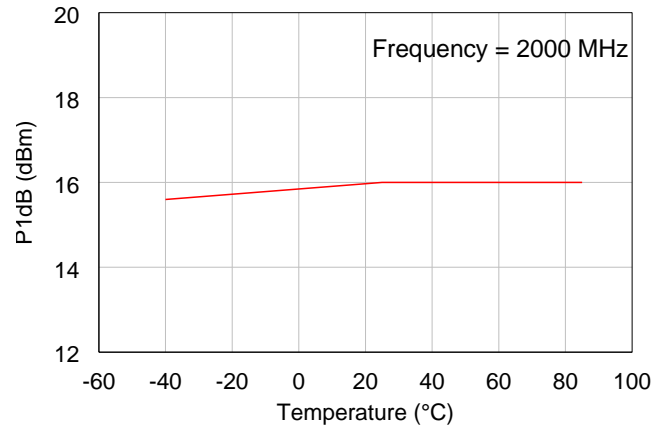
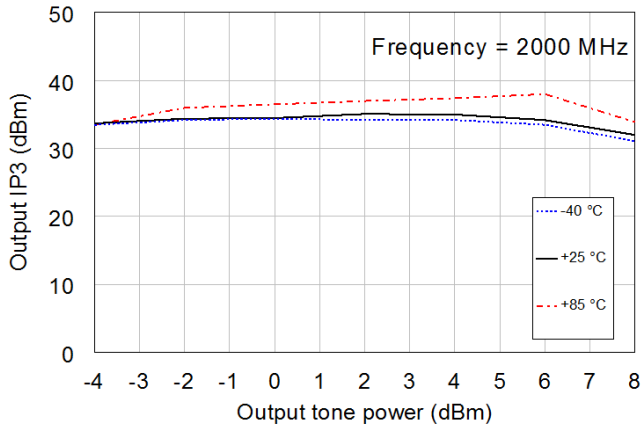

4. Application: 30 ~ 1200 MHz (IF, CATV)

4.1 Application Circuit & Evaluation Board

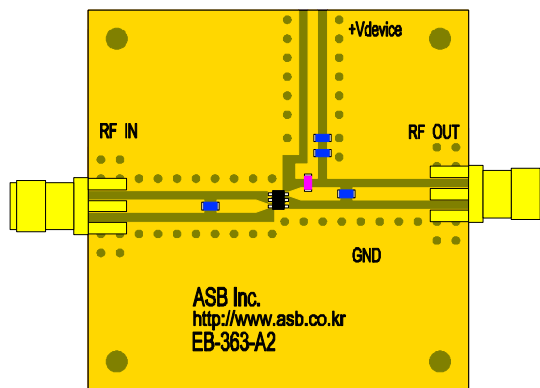
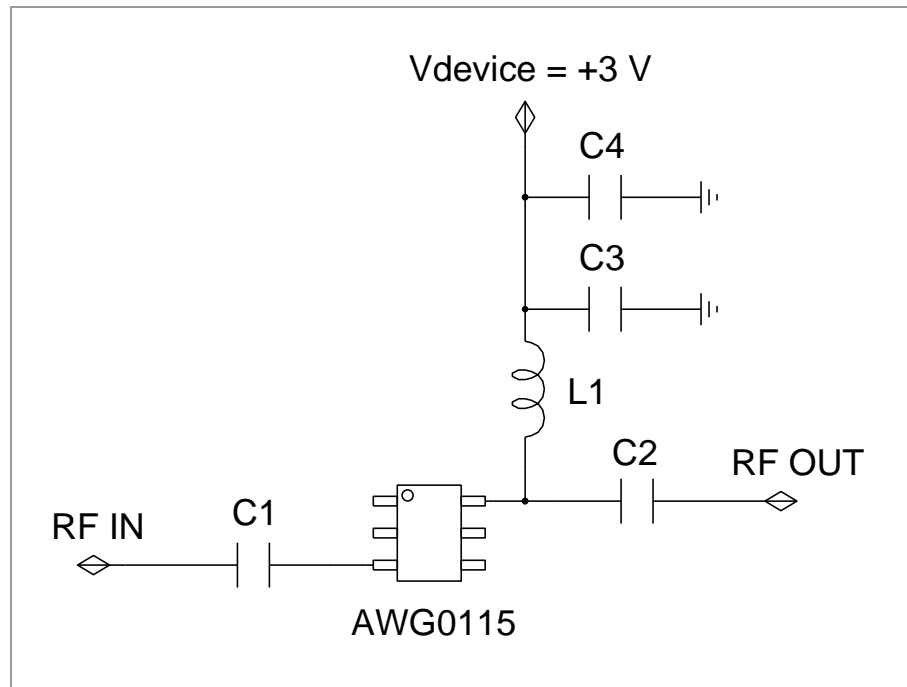

PCB Information	
Material	FR4
Thickness (mm)	0.8
Size (mm)	40x40
EB No.	EB-363-A2

Bill of Material

Symbol	Value	Size	Description	Manufacturer
AWG0115	-	-	MMIC Amplifier	ASB
C1, C2	1 μ F	0603	DC blocking capacitor	Murata
C3	-	-	Not used	
C4	10 μ F	0805	Decoupling capacitor	Murata
L1	3.3 μ H	0603	RF choke inductor	Samsung

4.2 Performance Table

Supply voltage = +3 V, T_A = +25 °C, Z₀ = 50 Ω.

Parameter	Typical								Unit
Frequency	30	70	150	300	450	860	1000	1200	MHz
Gain	16.2	15.4	15.2	15.1	15.1	14.8	14.7	14.6	dB
S11	-11.0	-18.0	-20.0	-20.0	-20.0	-20.0	-18.0	-17.0	dB
S22	-18.0	-18.0	-18.0	-20.0	-20.0	-20.0	-20.0	-20.0	dB
Noise Figure	2.4	2.3	2.3	2.3	2.3	2.3	2.3	2.3	dB
Output IP3 ¹⁾	32.0	32.0	33.0	34.0	33.0	32.0	32.0	30.0	dBm
Output P1dB	16.0	16.0	16.0	16.0	16.0	16.0	16.0	16.0	dBm
Current	57								mA
Device Voltage	+3								V

1) OIP3 is measured with two tones at an output power of +0 dBm/tone separated by 1MHz.

4.3 Plot of S-parameter & Stability Factor

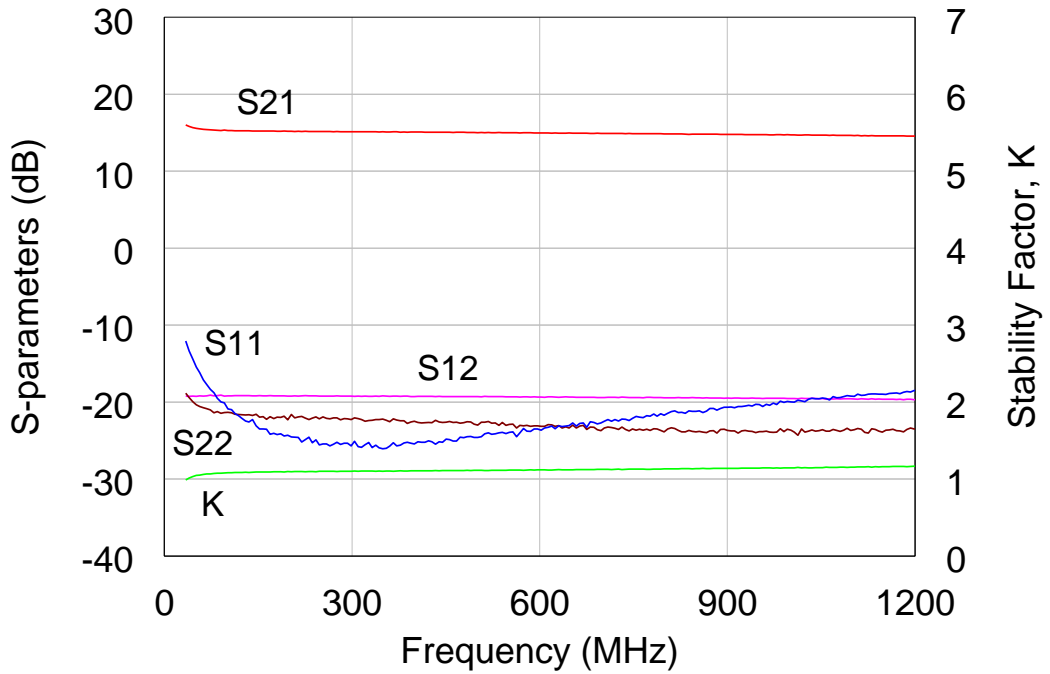

5. Application: 50 ~ 3000 MHz (SMATV, ONU)

5.1 Application Circuit & Evaluation Board

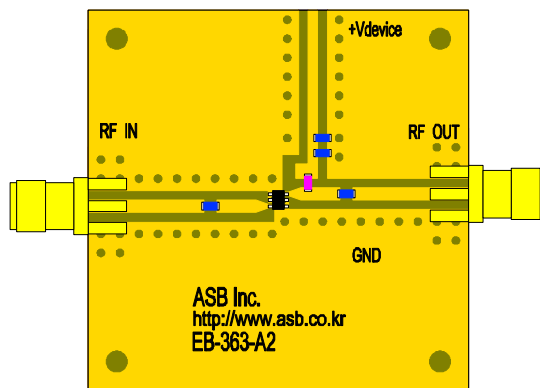
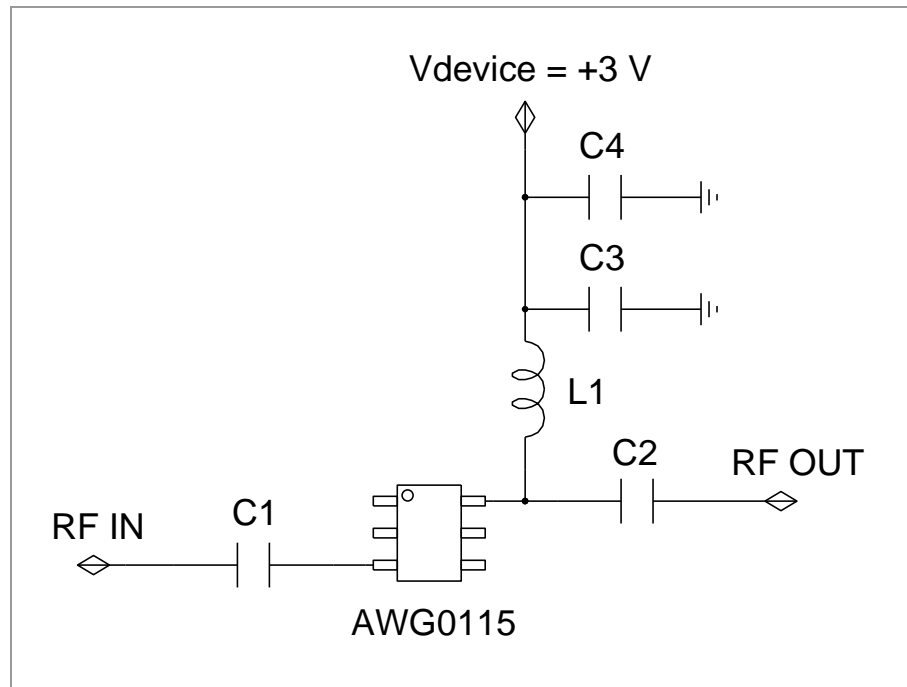

PCB Information	
Material	FR4
Thickness (mm)	0.8
Size (mm)	40x40
EB No.	EB-363-A2

Bill of Material

Symbol	Value	Size	Description	Manufacturer
AWG0115	-	-	MMIC Amplifier	ASB
C1, C2	1 μ F	0603	DC blocking capacitor	Murata
C3	-	-	Not used	
C4	10 μ F	0805	Decoupling capacitor	Murata
L1	1 μ H	0603	RF choke inductor	Samsung

5.2 Performance Table

Supply voltage = +3 V, T_A = +25 °C, Z₀ = 50 Ω.

Parameter	Typical						Unit
Frequency	50	500	1000	2000	2500	3000	MHz
Gain	15.4	14.9	14.5	13.2	12.5	11.7	dB
S11	-13.0	-20.0	-18.0	-17.0	-15.0	-14.0	dB
S22	-18.0	-18.0	-18.0	-14.0	-12.0	-9.0	dB
Noise Figure	2.3	2.3	2.3	2.7	3.1	3.5	dB
Output IP3 ¹⁾	30.0	33.0	31.0	29.0	26.0	23.0	dBm
Output P1dB	16.0	16.0	16.0	15.0	14.0	14.0	dBm
Current	57						mA
Device Voltage	+3						V

1) OIP3 is measured with two tones at an output power of +0 dBm/tone separated by 1MHz.

5.3 Plot of S-parameter & Stability Factor

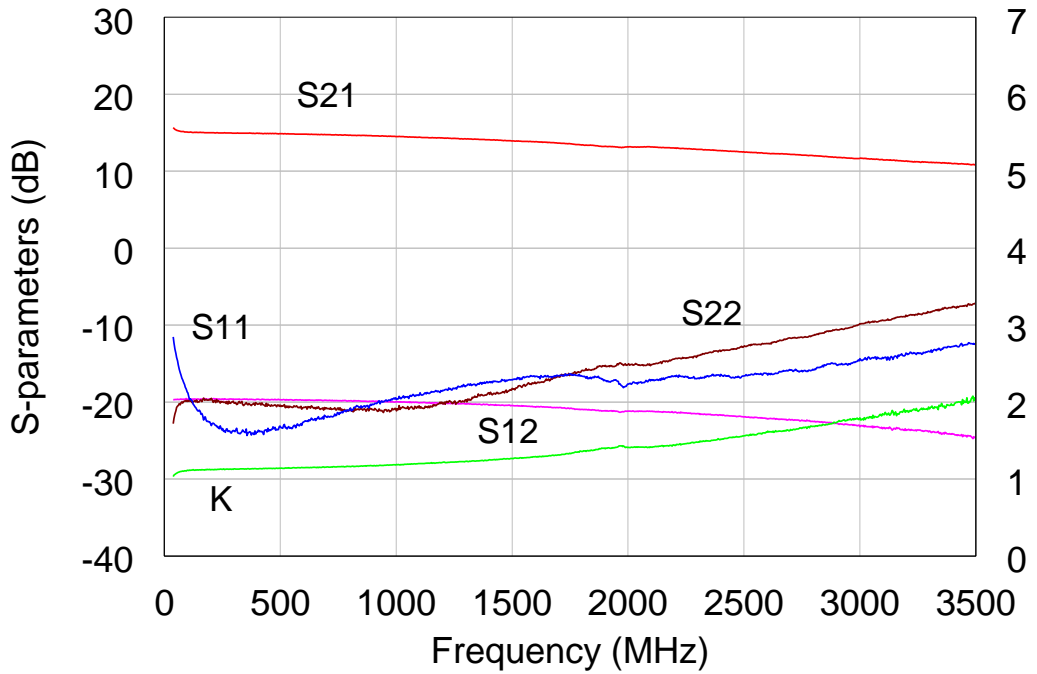

6. Package Outline (SOT363, 2.1x2.0x1.0 mm)

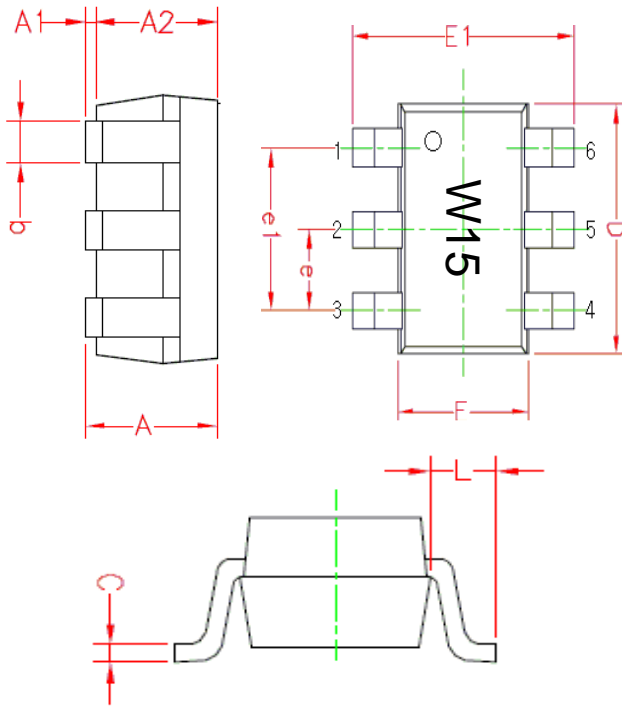

Symbols	Dimensions (In mm)		
	MIN	NOM	MAX
A	0.900	1.000	1.10
A1	0.025	0.062	0.10
A2	0.875	0.937	1.00
b	0.200	0.300	0.40
C	0.100	0.125	0.15
D	1.900	2.000	2.10
F	1.150	1.250	1.35
E1	2.000	2.100	2.20
e	0.65BSC		
e1	1.30BSC		
L	0.425REF		

7. Surface Mount Recommendation (In mm)

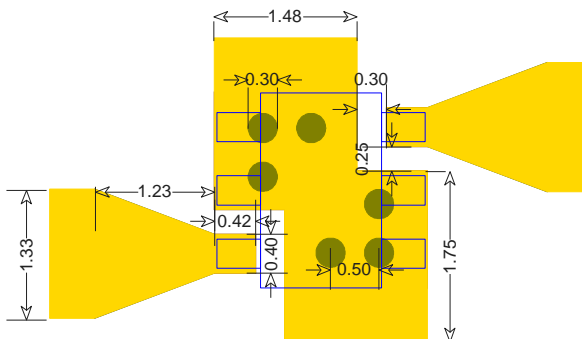

NOTE

1. The number and size of ground via holes in a circuit board are critical for thermal and RF grounding considerations.
2. Recommend is that the ground via holes be placed on the bottom of the ground leads and exposed pad of the device for better RF and thermal performance, as shown in the drawing at the left side.

8. Recommended Soldering Reflow Profile

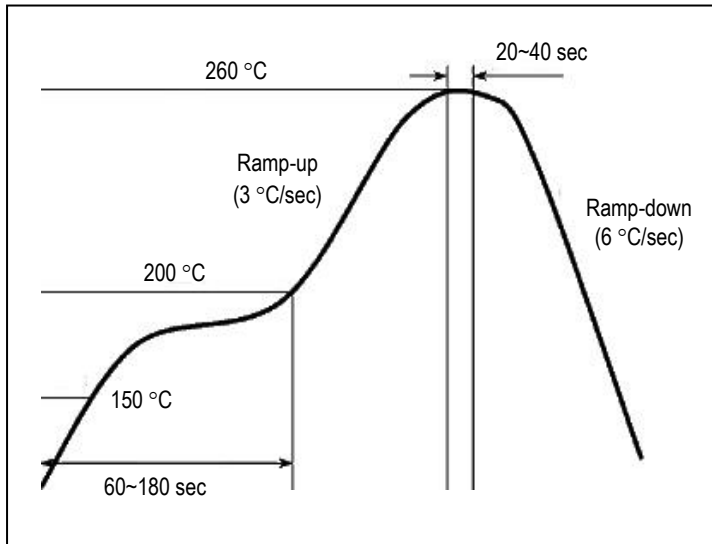

(End of Datasheet)