

PERFORMANCE SPECIFICATION SHEET

OSCILLATOR, CRYSTAL CONTROLLED, TYPE 1 (CRYSTAL OSCILLATOR (XO)),
 1.0 MHz THROUGH 85 MHz, HERMETIC SEAL, SQUARE WAVE, TTL

This specification is approved for use by all Departments
 and Agencies of the Department of Defense.

The requirements for acquiring the product described herein
 shall consist of this specification sheet and [MIL-PRF-55310](#).

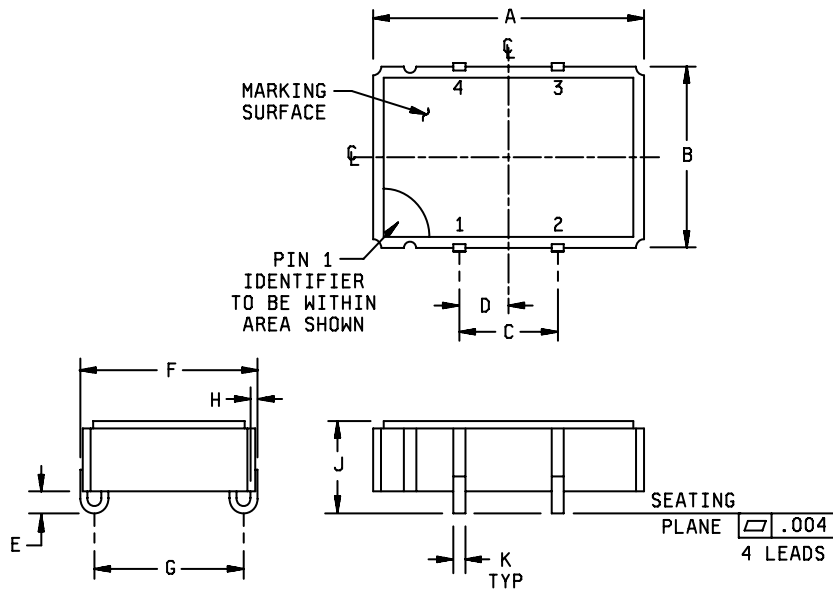

Pin number	Function
1	Enable/disable
2	GND
3	Output
4	B+

Ltr	Inches		mm	
	Min	Max	Min	Max
A	N/A	.560	N/A	14.22
B	N/A	.360	N/A	9.14
C	.195	.205	4.95	5.21
D	.086	.114	2.18	2.90
E	.025	.055	.635	1.40
F	N/A	.378	N/A	9.60
G	.292	.308	7.42	7.82
H	.007	.009	.178	.229
J	N/A	.188	N/A	4.78
K	.015	.021	.381	.533

NOTES:

1. Dimensions are in inches.
2. Metric equivalents are given for general information only.
3. Unless otherwise specified, tolerances are ± 0.005 (0.13 mm) for three place decimals and ± 0.02 (0.5 mm) for two place decimals.

FIGURE 1. Dimensions and configuration.

REQUIREMENTS:

Interface and physical dimensions: See figure 1.

Mounting: See figure 1.

Pads: See figure 1.

Seal: Hermetic in accordance with [MIL-PRF-55310](#), maximum leakage rate 5×10^{-8} atm cc/s.

Weight: 3 grams, maximum.

Oscillator: Class 2 or any class 1 or class 3 oscillator meeting all class 2 requirements and verification tests specified herein and in [MIL-PRF-55310](#).

Calibration: Manufacturer calibrated.

Screening: In accordance with [MIL-PRF-55310](#), product level B or S, as applicable.

Temperature:

Operating: See table I.

Storage: -62°C to +125°C.

Oscillator load: Standard TTL loads (see table I).

Output waveform: Symmetrical square wave.

Output voltage:

Logic 1: 2.4 V dc minimum at 400 μ A source.

Logic 0: 0.5 V dc maximum with 16 mA sink.

Rise and fall times: See table I.

Duty cycle: See table I.

Supply voltage: +5 V dc \pm 10 percent.

Input current: See table I.

Enable/disable:

Output disabled (high impedance): Pin 1 input \leq 0.8 V dc.

Output active: Pin 1 input \geq 2.0 V dc or open.

Output frequency: Frequency as designated at time of acquisition (see table I).

Initial accuracy at reference temperature (up to 30 days after shipment): See table I.

MIL-PRF-55310/28C

TABLE I. Dash numbers and operating characteristics.

Dash number	Output frequency range	Input current max 1/	Pulse characteristics			Initial accuracy ppm at +23°C ±1°C	Frequency-temperature tolerance (ppm)		
			Rise and fall times (max)	Duty cycle at 1.4 V	Load (max) 2/		-55°C to +125°C	-55°C to +105°C	-20°C to +70°C
							A	B	C
01	1.000 MHz to 14.999 MHz	10 mA	5 ns	45% to 55%	10 TTL	±15 ppm	±50 ppm	±40 ppm	±25 ppm
04	1.000 MHz to 14.999 MHz	10 mA	5 ns	45% to 55%	10 TTL	±25 ppm	±100 ppm	±80 ppm	±50 ppm
11	15.000 MHz to 29.999 MHz	15 mA	5 ns	40% to 60%	10 TTL	±15 ppm	±50 ppm	±40 ppm	±25 ppm
14	15.000 MHz to 29.999 MHz	15 mA	5 ns	40% to 60%	10 TTL	±25 ppm	±100 ppm	±80 ppm	±50 ppm
21	30.000 MHz to 59.999 MHz	25 mA	3 ns	40% to 60%	10 TTL	±15 ppm	±50 ppm	±40 ppm	±25 ppm
24	30.000 MHz to 59.999 MHz	25 mA	3 ns	40% to 60%	10 TTL	±25 ppm	±100 ppm	±80 ppm	±50 ppm
31	60.000 MHz to 85.000 MHz	40 mA	3 ns	40% to 60%	10 TTL	±15 ppm	±50 ppm	±40 ppm	±25 ppm
34	60.000 MHz to 85.000 MHz	40 mA	3 ns	40% to 60%	10 TTL	±25 ppm	±100 ppm	±80 ppm	±50 ppm

1/ Maximum input current for no load condition. Actual configuration of TTL loads must be added to determine power supply requirements.

2/ A TTL unit load is defined as: 1.6 mA sink, 0.04 mA source, and 2 pF capacitance.

Frequency-temperature tolerance (one-half temperature cycle, referenced to frequency measured at +23°C ±1°C, immediately prior to starting of the test): See table I. Measurements taken at ten equally spaced increments over the specified operating temperature range. 1/

Frequency-voltage tolerance: ±4 ppm maximum for a ±10 percent change in supply voltage. Measurements taken at reference temperature and operating temperature range end points.

Frequency aging: Measurements shall be taken at +70°C ±0.2°C at intervals of not more than every 72 hours for a minimum of 30 days (see table I).

±10 ppm per year, maximum

±1.5 ppm per 30 days.

±3 ppm per 90 days.

Terminal strength: Method 211 of MIL-STD-202, test condition A.

Applied force: 8 ounces each terminal.

1/ For the purpose of transitioning this device to MIL-PRF-55310, 'Frequency stability versus temperature' has been renamed 'Frequency-temperature tolerance'. The verification requirements of 'initial frequency-temperature accuracy (one-half temperature cycle)' shall apply except that frequency measurements shall be referenced to the frequency measured at +23°C ±1°C (f_{ref}) instead of to the nominal frequency (f_{nom}).

MIL-PRF-55310/28C

Frequency-environmental tolerance: Not applicable.

Vibration, sinusoidal: In accordance with [MIL-PRF-55310](#) and [method 204 of MIL-STD-202](#).

Nonoperating: Test condition D.

Operating: Not required.

Ambient pressure:

Nonoperating: In accordance with [MIL-PRF-55310](#).

Operating: [Method 105 of MIL-STD-202](#), test condition C.

Exposure time: 5 minutes.

Reflow soldering: Reflow soldering of the unit at +230°C ±10°C for 15 seconds shall not degrade the performance.

Part or Identifying Number (PIN): Consists of "M" prefix followed by specification sheet number, a dash and coded alphas, and numeric number. See example:

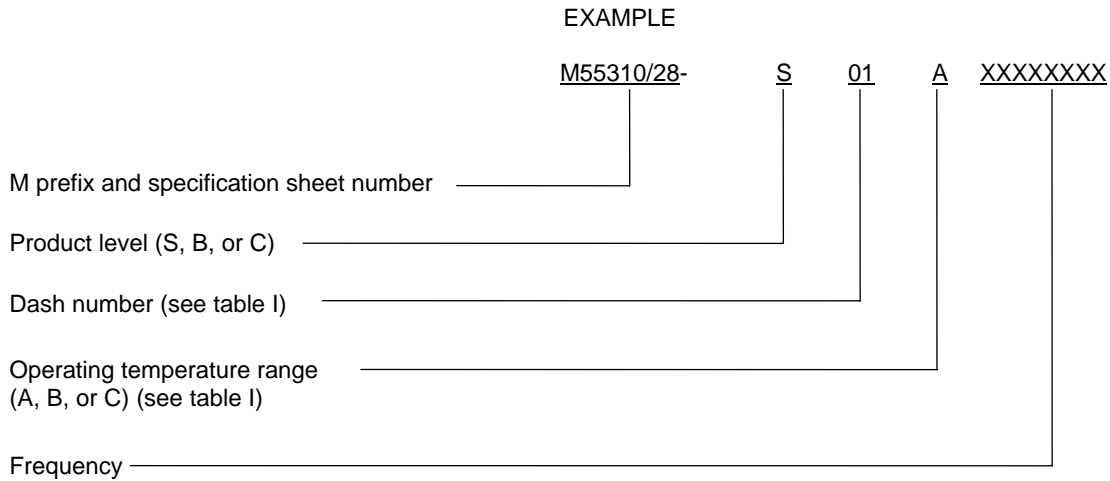

Reference documents. In addition to [MIL-PRF-55310](#), this document references the following:
[MIL-STD-202](#)

The margins of this specification are marked with vertical lines to indicate where changes from the previous issue were made. This was done as a convenience only and the Government assumes no liability whatsoever for any inaccuracies in these notations. Bidders and contractors are cautioned to evaluate the requirements of this document based on the entire content irrespective of the marginal notations and relationship to the last previous issue.

Custodians:

Army - CR
Navy - EC
Air Force - 99
DLA - CC

Review activities:

Army - AR, MI, SM
Navy - AS, CG, MC
Air Force - 19, 84
NASA - NA

Preparing activity:

Army - CR

Agent:

DLA - CC

(Project 5955-2008-008)

NOTE: The activities listed above were interested in this document as of the date of this document. Since organizations and responsibilities can change, you should verify the currency of the information above using the ASSIST Online database at <http://assist.daps.dla.mil>.