

- NOTES:
1. PACKAGE CABLE ASSEMBLY IN BAG. TAG IN BAG WITH "AMPHENOL CONNEX, 115104-15-XX.XX AND DATE CODE".
  2. CABLE ASSEMBLY TO BE 100% TESTED FOR HI-POT, CONTINUITY, SHORTS AND OPEN.

115103-15-XX.XX		REVISIONS			
DRAWING NO.	REV	DESCRIPTION	DATE	ECO	APPR
THIRD ANGLE PROJ.	A	RELEASE TO MFG.	11-Nov-10	--	KR

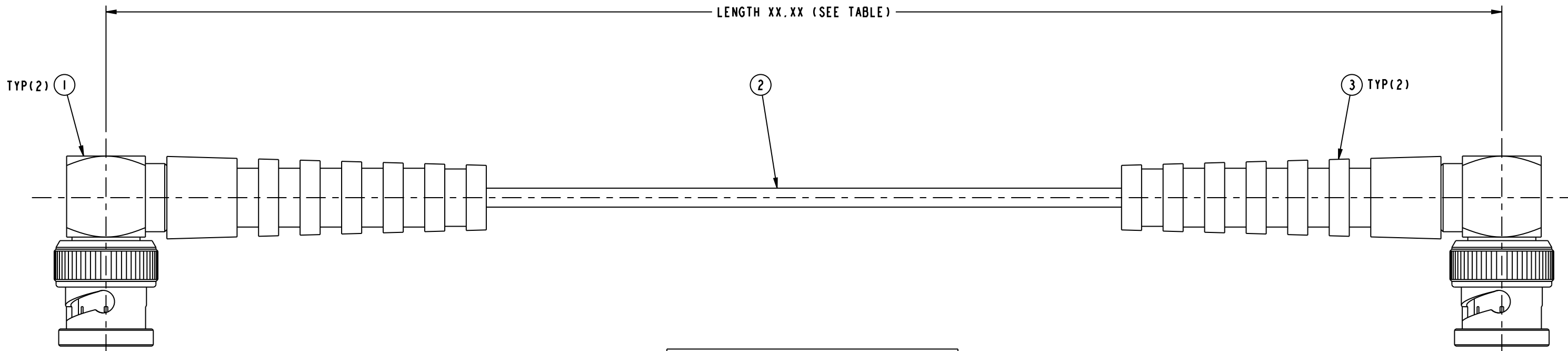
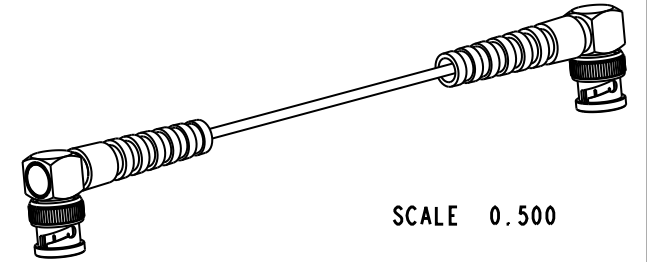

PART NUMBER	LENGTH INCHES (X)
115104-15-06.00	6.000
115104-15-12.00	12.000
115104-15-24.00	24.000
115104-15-36.00	36.000

\* ADDITIONAL LENGTH CAN BE PROVIDED BY CHANGING XX.XX TO DESIRED LEGNTH IN INCHES CONTACT CONNEX MARKETING FOR QUOTE

**DESIGN REQUIREMENTS:**

FREQUENCY \_\_\_\_\_ TO \_\_\_\_\_ GHz     CONTINUITY

VSWR \_\_\_\_\_ : 1 MAX     HI-POT : 1000 VRMS

INS. LOSS \_\_\_\_\_ dB MAX     OTHER

60030-000	A/R	4	STRAIN RELIEF BOOT	BLACK
009-881-457	A/R	3	RG 59 CO-AXIAL CABLE	
112165	2	1	BNC R/A CRIMP PLUG	
PART NUMBER	QTY	ITEM	DESCRIPTION	FINISH

UNLESS OTHERWISE SPECIFIED, DIMENSIONS ARE IN INCHES AND TOLERANCES ARE: 2 PLACE DECIMAL ±.015 (0,381 mm)    3 PLACE DECIMAL ±.005 (0,127 mm)    ANGLES ± 1°	MATERIAL	DRAWN KARTHIK R	DATE 11-Nov-10	TITLE BNC R/A CRIMP PLUG TO BNC R/A CRIMP PLUG USING, RG 59 CO-AXIAL CABLE, XX.XX LENGTH	Amphenol Connex		
	REFERENCE TASK - 480	ENGINEER KARTHIK R	DATE 11-Nov-10				
NOTICE - These drawings, specifications, or other data (1) are, and remain the property of Amphenol Corp. (2) must be returned upon request; and (3) are confidential and not to be disclosed to any person other than those to whom they are given by Amphenol Corp. The furnishing of these drawings, specifications, or other data by Amphenol Corp., or to any other person to anyone for any purpose is not to be regarded by implication or otherwise in any manner licensing, granting rights or permitting such holder or any other person to manufacture, use or sell any product, process or design, patented or otherwise, that may in any way be related to or disclosed by said drawings, specifications, or other data.		APPROVED	DATE	CAD FILE Root folder:/Cable assembly/115104-15-XX.XX	DWG SIZE B	DRAWING NO. 115104-15-XX.XX	REV A
				SCALE: 1.8:1	SHEET 1 OF 1		