

Product Features

- 2-Way Splitter
- 30 ~ 1200MHz(1dB Flat)
- Small size (3X3 mm)
- QFN SMD Type package
- Higher productivity
- Lower manufacturing cost
- -59dBc CSO 135 Channels @ +15dBmV/ch
- -71dBc CTB 135 Channels @ +15dBmV/ch
- -73dBc XMD 135 Channels @ +15dBmV/ch
- 3.5 dB Typical Noise Figure
- 75 ohm input and outputs

Applications

- Multi Tuner Set-Top Boxes
- Home Gateways
- FTTx (G-PON, GE-PON)



Package Type : QFN 3X3

Description

AD254 is designed as low cost Active Divider for many applications including FTTH, CATV System. This MMIC is based on Gallium Arsenide Enhancement Mode pHEMT which shows low current draw and very low noise. The data in this spec sheet is valid only for 75ohm application.

Electrical Specifications

PARAMETER		UNIT	MIN	TYP	MAX	Typ
Frequency		MHz	30 ~ 1000			-
Gain		dB	3.0	4.5	-	4
Gain Flatness		dB		0.6	1	1
Input Return Loss		dB	-	-16	-	-14
Output Return Loss		dB	-	-21	-	-20
IN&OUT Port Isolation		dB	-	-30	-	-30
OUT&OUT Port Isolation		dB	-	-20	-	-20
Output IP3		dBm	24	28	-	28
1dB Compression Point		dBm	8	12	-	8
Noise Figure		dB	-	3.5	5	3.5
CSO	50 ~ 870MHz 135 channel@ Input Power +15dBmV/ch	dBc	-	-59	-	-55
CTB		dBc	-	-71	-	-62
XMOD		dBc	-	-73	-	-61
DC Current		mA	-	110	-	75
Supply Voltage		V	5			3.3

Note

1. Test conditions unless otherwise noted. Test Freq = 500MHz, T=25°C, V_{dd}=5V, 75Ω system
2. OIP3 measured with 2 tones at an output power of +0dBm/tone separated by 1MHz, Test Freq = 500MHz

Absolute Maximum Ratings

PARAMETER	UNIT	MIN	TYP	MAX
Device Voltage	VDC	-	5	5.5
Operating Temperature	°C	-40	-	85
Storage Temperature	°C	-40	-	150
ESD Human Body Model	-	-	Class 1A	-
Moisture sensitivity Level	-	-	MSL1	-

Application Circuit @ 30 ~ 1000MHz, Vdd = +5V, 75ohm System

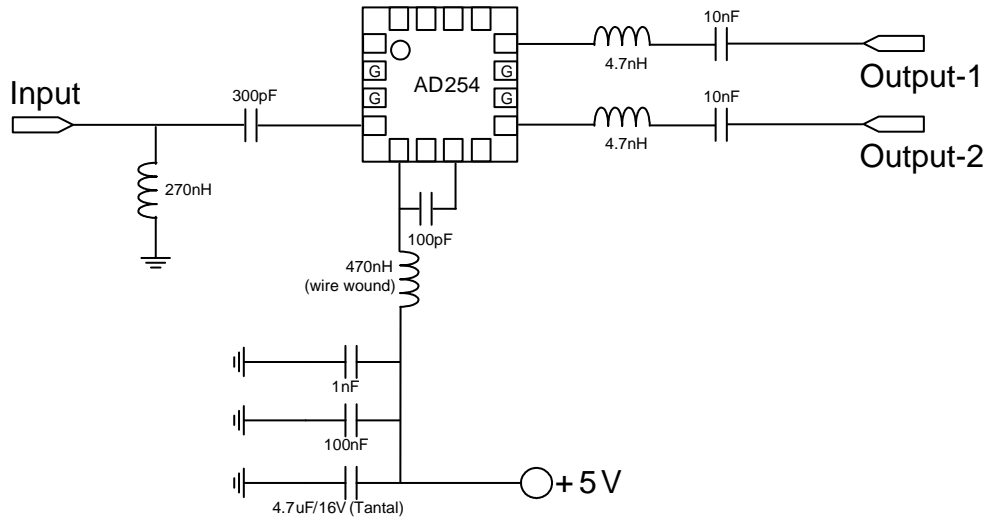

S-Parameter

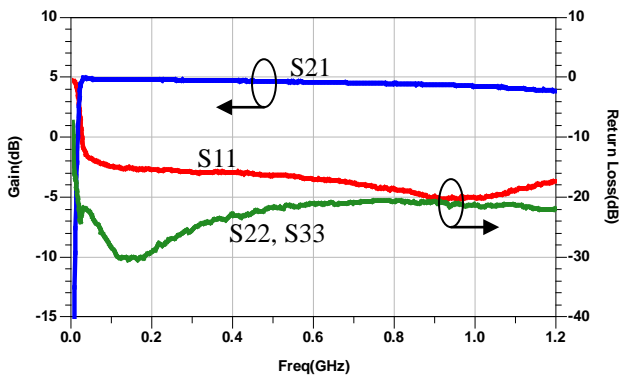

Isolation

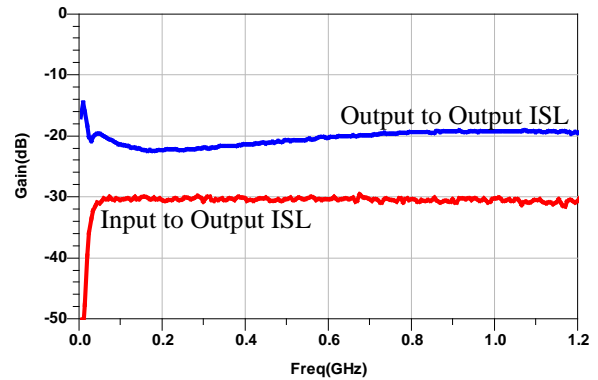

Noise Figure

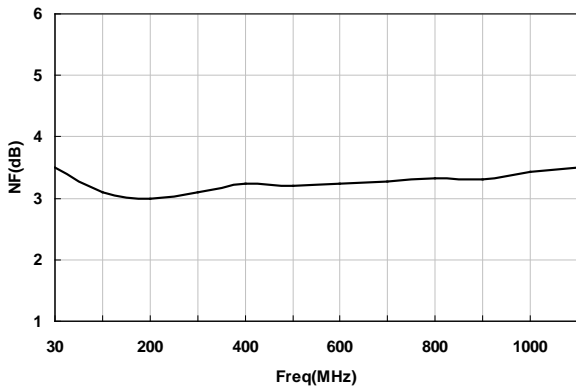

Application Circuit @ 30 ~ 1000MHz, +3.3V, 75ohm System

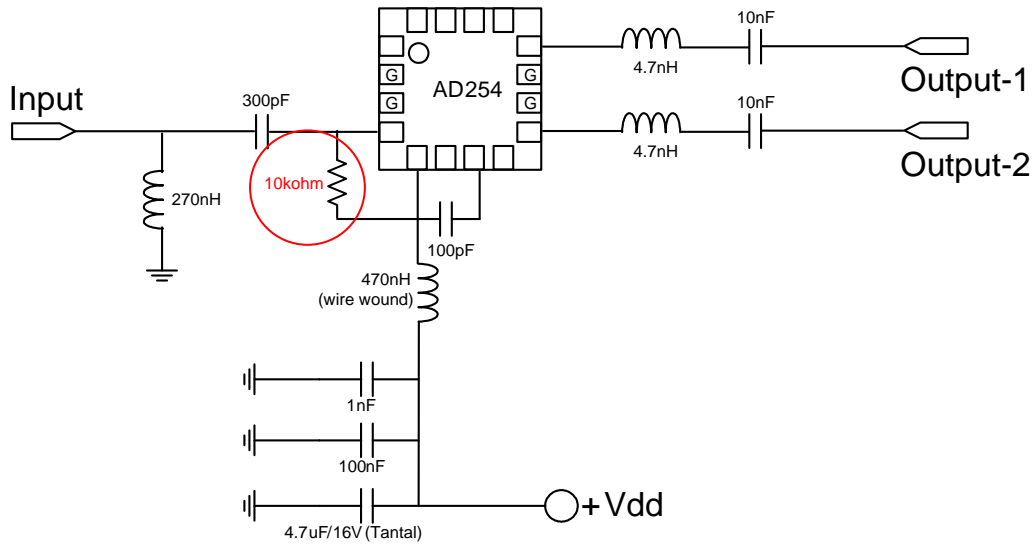

S-Parameter

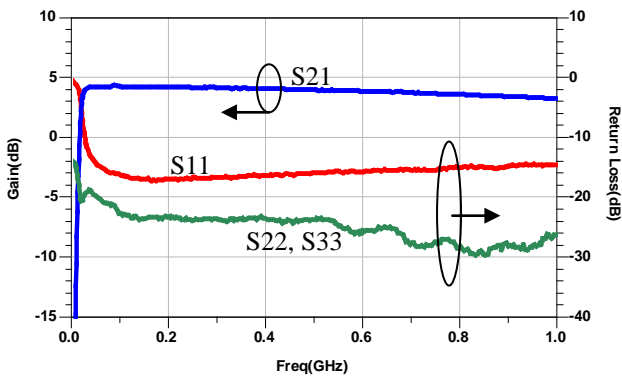

Isolation

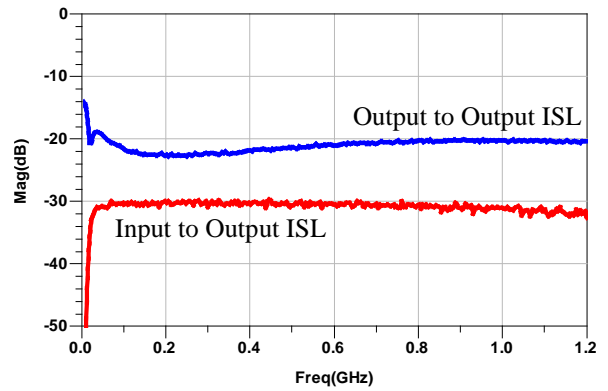

Noise Figure

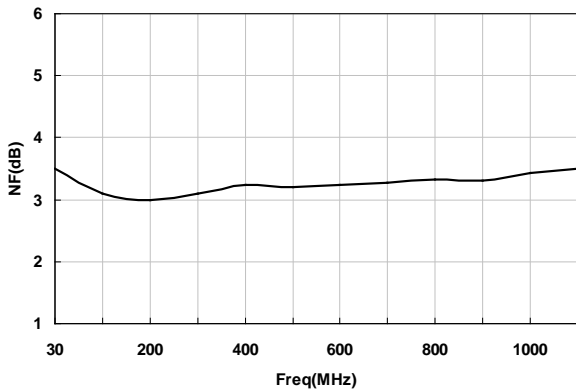

Multi-Tone Test : 135CH_FLAT@Input Power +15dBmV/Ch

Level : Input +15dBmV Tilt : 135CH										
FRQ	XMOD	CTB RAW	CTB COR	N-FLR	CSU RAW	CSU COR	CSU FRQ	CSL RAW	CSL COR	CSL FRQ
55.25	76.5	79.8	84.1	81.5	78.6	82.2	55.99	59.3	59.3	53.99
77.25	82.6	80.2	84.6	81.7	60.3	60.3	77.99	81.3	85.6	76.61
109.25	82.2	80.1	84.4	81.5	78.4	80.9	109.99	61.2	61.2	107.99
211.25	84.6	77.9	80.9	81	76.9	79.1	211.99	62.7	62.7	209.99
331.25	82	75.7	77.6	80	75.3	77.2	331.99	63.1	63.1	329.99
547.25	78	72.9	74.2	79	74.3	76.2	548.49	64.1	64.3	545.99
637.25	75.7	72	73.1	78.7	74.2	76.1	638.49	66.3	66.6	635.99
745.25	75	71.5	72.5	78.7	73.2	74.6	746.49	69.6	70.2	743.99
859.25	73.3	70.9	72.4	76.7	71.7	73.3	860.49	75.6	79.9	858.49
Min	73.3	70.9	72.4	76.7	60.3	60.3	55.99	59.3	59.3	53.99
Max	84.6	80.2	84.6	81.7	78.6	82.2	860.49	81.3	85.6	858.49

Multi-Tone Test : 135CH_FLAT@Input Power +15dBmV/Ch, Vdd = +3.3V

Level : Input +15dBmV Tilt : 135CH_FLAT										
FRQ	XMOD	CTB RAW	CTB COR	N-FLR	CSU RAW	CSU COR	CSU FRQ	CSL RAW	CSL COR	CSL FRQ
55.25	68.3	65.6	69.9	65.8	65.4	69.8	55.99	55.7	56.1	54
77.25	69.8	65.5	69.8	65.9	56.4	56.9	77.99	65.5	69.9	76.61
109.25	70.6	65.6	69.9	66	65.1	69.5	109.99	56.3	56.8	107.99
211.25	69.7	65.2	69.6	66.1	65.3	69.7	211.99	56.7	57.2	209.99
331.25	68.7	64	68.3	65.1	64.2	68.5	331.99	57.2	57.9	329.99
445.25	67.1	63.8	68.1	65.6	63.5	67.8	446.49	57	57.6	443.99
547.25	66.1	63.3	67.7	64.7	62	65.1	548.49	57.7	58.6	545.99
637.25	64.8	62.8	67.1	64.8	60.9	63.1	638.49	58.7	59.8	635.98
745.25	63	62.7	67	64.9	59.5	60.9	746.49	60.4	62.3	743.99
859.25	61.4	62.6	67	64.2	59	60.6	860.49	63.4	67.7	858.49
Min	61.4	62.6	67	64.2	56.4	56.9	55.99	55.7	56.1	54
Max	70.6	65.6	69.9	66.1	65.4	69.8	860.49	65.5	69.9	858.49

Package Dimensions (Type: QFN3x3)

* Unit: mm[inch] | Tolerance: ± 0.2 [.008]

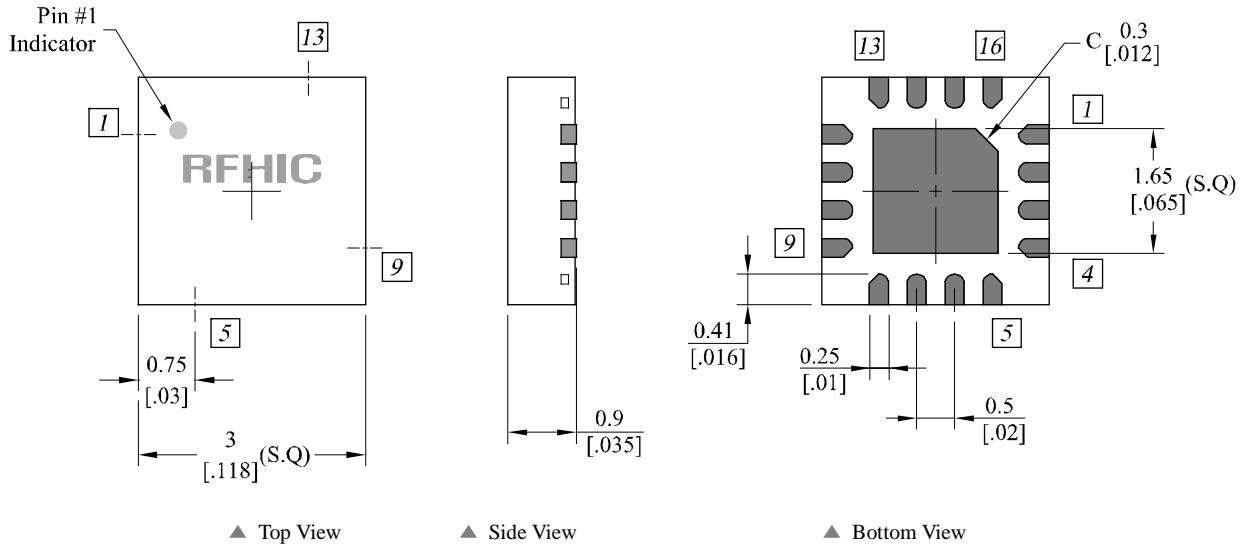

Pin Description							
Pin No	Function	Pin No	Function	Pin No	Function	Pin No	Function
1	NC	5	Bias/Port1	9	Output-1	13	NC
2	GND	6	NC	10	GND	14	NC
3	GND	7	Port2	11	GND	15	NC
4	Input	8	NC	12	Output-2	16	NC

*** Mounting Configuration Notes**

1. Ground / thermal via holes are critical for the proper performance of this device.
2. Add as much copper as possible to inner and outer layers near the part to ensure optimal thermal performance.
3. Mounting screws can be added near the part to fasten the board to a heatsink. Ensure that the ground / thermal via hole region contacts the heatsink.
4. Do not put solder mask on the backside of the PCB in the region where the board contacts the heatsink.
5. RF trace width depends upon the PCB material and construction.
6. Use 1 oz. Copper minimum.

Revision History

Part Number	Release Date	Version	Modification	Data Sheet Status
AD254	2013.01.08	1.3	Change by a new dimension form	-
AD254	2012.09.10	1.2	Change by a new document form	-
AD254	2012.02.06	1.1	3.3V Application Circuit was added	-

RFHIC Corporation reserves the right to make changes to any products herein or to discontinue any product at any time without notice. While product specifications have been thoroughly examined for reliability, RFHIC Corporation strongly recommends buyers to verify that the information they are using is accurate before ordering. RFHIC Corporation does not assume any liability for the suitability of its products for any particular purpose, and disclaims any and all liability, including without limitation consequential or incidental damages. RFHIC products are not intended for use in life support equipment or application where malfunction of the product can be expected to result in personal injury or death. Buyer uses or sells such products for any such unintended or unauthorized application, buyer shall indemnify, protect and hold RFHIC Corporation and its directors, officers, stockholders, employees, representatives and distributors harmless against any and all claims arising out of such unauthorized use.

Sales, inquiries and support should be directed to the local authorized geographic distributor for RFHIC Corporation. For customers in the US, please contact the US Sales Team at 919-677-8780. For all other inquiries, please contact the International Sales Team at 82-31-250-5078.