

All components used in this connector conform to RoHS standards.



Tolerances

- 1-20=+/-0.2
- 20-30=+/-0.3
- 30-40=+/-0.4
- 40-50=+/-0.5
- 50-100=+/-0.75
- 100-300=+/-1.5
- Angles=+/-1

Dimensions are in Millimeters

Revisions Description/Approved/Date	Approved M.H.	Date 08/20/01
	Checked M.H.	Date 08/19/01
	Drawn K.R.E.	Date 08/17/01
NOTES (plating thickness in micro-inches): 1. Per QQ-B-626 2. Per QQ-S-764 3. Per QQ-C-530 4. Per QQ-B-750 5. Per MIL-P-19468 6. Per ZZ-R-765 7. Per WW-T-799 8. Gold pl. 5 min. over nickel pl. 50 min. over copper strike 9. Nickel pl. 100 min. over copper strike 10. Per QQ-P-35 11. Gold pl. 30 min. over nickel pl. 50 min. over copper strike		

Approved by:
Date:

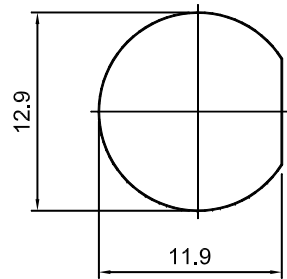

RECOMMENDED MOUNTING HOLE

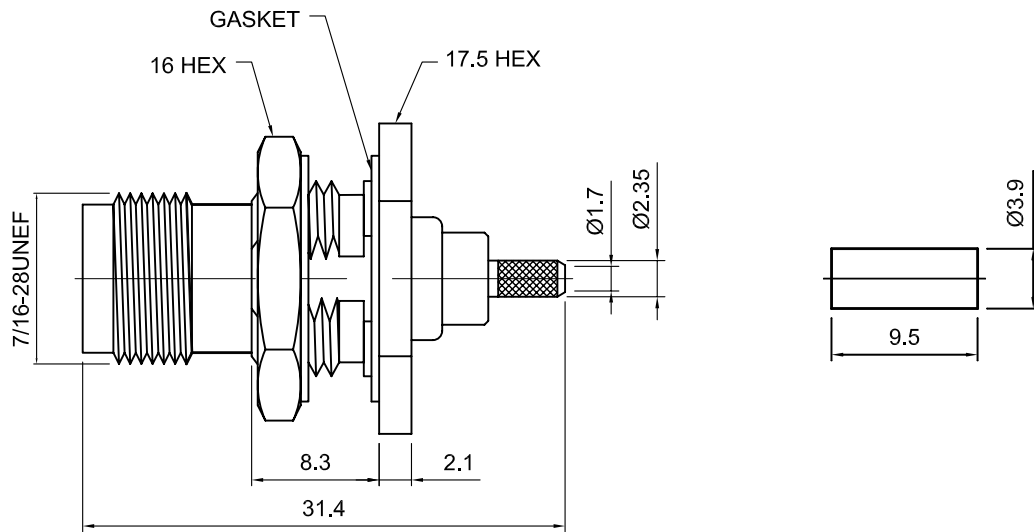

ITEM	MATERIAL	FINISH
Connector Body	Brass, Note 1	Nickel, Note 9
Center Contact: Female	Beryllium Copper, Note 3	Gold, Note 11
Insulation	Teflon, Note 5	None
Ferrule	Annealed Copper, Note 7	Same as body
Gasket	--	--
Hex Nut	Brass, Note 1	Same as body
Lock Washer	Brass, Note 1	Same as body

Lighthouse Technologies, Inc.

5640 Kearny Mesa Road, Suite N
San Diego, California 92111

Part Number:
LTI-TSF13RNT-316

Description TNC rear mount bulkhead crimp jack, 3.5 max panel		
Scale 2:1	Drawing No. TNC/TSF13-316	File Name TSF13-316