

- 1.0 PERFORMANCE
- 1.1 FREQUENCY RANGE: DC-4GHz
- 1.2 VOLTAGE RATING: 500V RMS (sea level)
- 1.3 NOMINAL IMPEDANCE: 50 OHMS
- 1.4 DWV: 1500 V RMS @ 60 Hz (sea level)
- 1.5 TEMPERATURE RANGE: -65°C TO +165°C
- 2.0 MATERIALS
- 2.1 DIELECTRIC: TEFLON, ASTM-D-1710
- 2.2 CENTER CONTACT: BeCu, ASTM-B-196

- 2.3 LOCKWASHER: PHOSPHOR BRONZE
- 2.4 OTHER METAL PARTS: BRASS, ASTM-B-16
- 2.5 GASKETS: SILICON RUBBER ZZ-R-765, GR 50 RED
- 3.0 FINISHES
- 3.1 CENTER CONTACT: SILVER PLATE
- 3.2 ALL OTHER METAL PARTS: NICKEL PLATE
- 4.0 MECHANICAL
- 4.1 INTERFACE IN ACCORDANCE WITH MIL-STD-348
- 4.2 ASSEMBLY INSTRUCTIONS PER SAN-TRON B-03

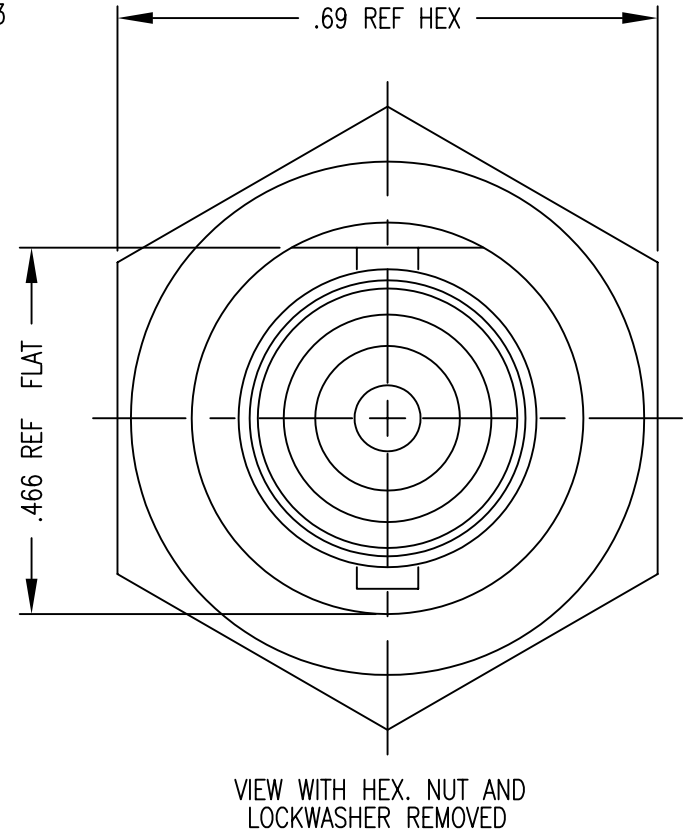
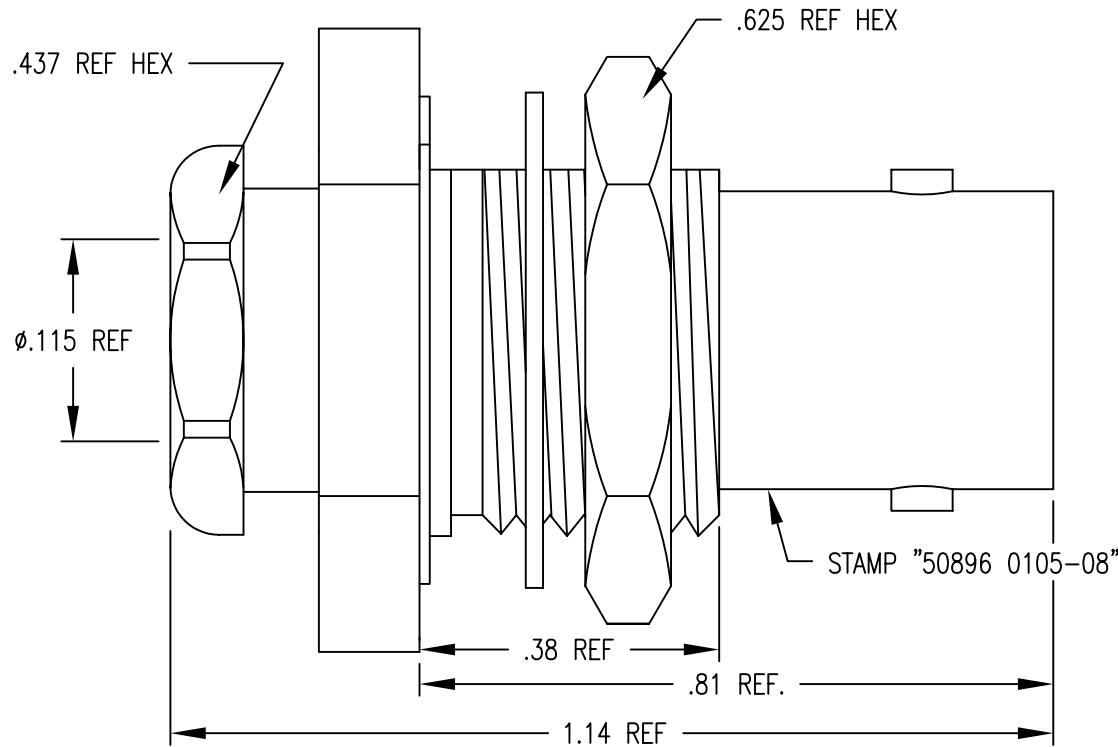

A	ORIGINAL	6/1/05			
Rev.	Revisions	Date	Dwn.	Appd.	
	RECOM. STOCK SIZE	FT/M PCS	QTY REQD		

PROPRIETARY
THIS DRAWING CONTAINS CONFIDENTIAL INFORMATION PROPRIETARY TO SAN*TRON INC. IT MUST NOT BE REPRODUCED OR DISCLOSED TO OTHERS OR USED IN ANY OTHER WAY, IN WHOLE OR PART EXCEPT AS AUTHORIZED IN WRITING BY SAN*TRON INCORPORATED.

REMOVE ALL BURRS AND SHARP EDGES .005 MAX.
UNLESS OTHERWISE STATED ALL DIMENSIONS ARE IN INCHES AND APPLY AFTER PLATING

UNSPECIFIED TOL.	DWN	FSH	6/1/05
DEC. ± .005	CHKD	SJS	6/1/05
FRAC. ± 1/64	APPR	FSH	6/1/05
ANG. ± 1/2°			

CONCENTRICITY .004 TIR
ALL MACHINED SURFACES \checkmark 63/

SAN • TRON, INC.
4 NEWBURYPORT TPK, IPSWICH, MA 01938

San-tron

TITLE BNC BULKHEAD JACK
RG-174A, 188, 316/U CABLES

MATERIAL: SEE NOTE 2.0 FINISH: SEE NOTE 3.0

FSCM NO. 50896 DWG NO. OL-0105-08-1 REV. A

SCALE 4:1