

| REV. | DATE | DESCRIPTION |
|------|----------|-----------------------|
| NC | 08/10/99 | INITIAL RELEASE |
| A | 12/28/05 | UPDATE DRAWING FORMAT |

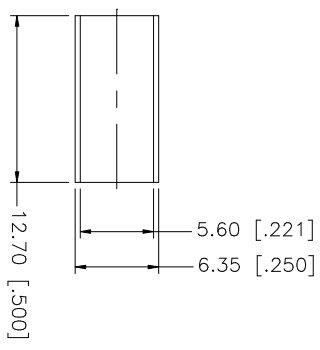
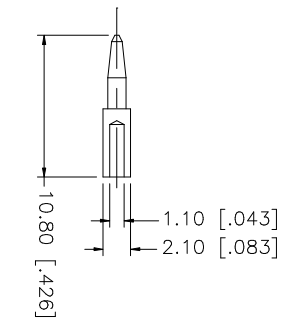
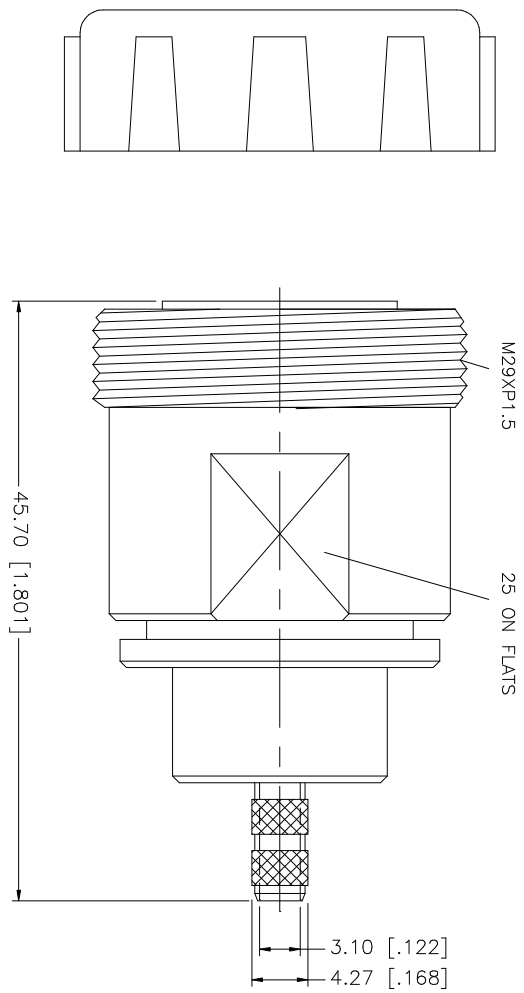
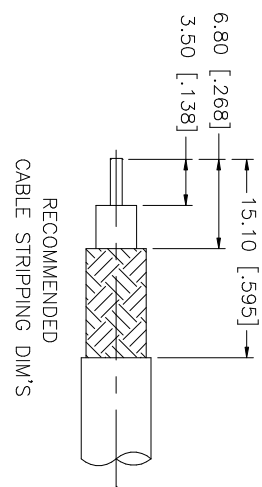

- NOTES:
1. CRIMPED FERRULE
HEX CRIMP SIZE .213"
 2. CRIMPED CONTACT PIN
HEX CRIMP SIZE .068"
OR CONTACT PIN TO SOLDER

| NO. | DESCRIPTION | MATERIAL | FINISH | QTY | UNLESS OTHERWISE SPECIFIED DIMENSIONS ARE IN MILLIMETERS. DIMENSIONS IN [] ARE IN INCHES AND FOR CONSUMER REFERENCE ONLY. | APPROVALS | DATE | PART DESCRIPTION |
|----------------------|-------------|----------|---------|-----|--|-----------|------|--|
| 8 | | | | | UNLESS OTHERWISE SPECIFIED DIMENSIONS ARE IN MILLIMETERS. DIMENSIONS IN [] ARE IN INCHES AND FOR CONSUMER REFERENCE ONLY. | | | Amphenol Connex 7/16 CRIMP JACK (FOR RG-142A, 223/U, 400/U CABLE) 272141 |
| 7 | | | | | UNLESS OTHERWISE SPECIFIED DIMENSIONS ARE IN MILLIMETERS. DIMENSIONS IN [] ARE IN INCHES AND FOR CONSUMER REFERENCE ONLY. | | | |
| 6 | | | | | UNLESS OTHERWISE SPECIFIED DIMENSIONS ARE IN MILLIMETERS. DIMENSIONS IN [] ARE IN INCHES AND FOR CONSUMER REFERENCE ONLY. | | | |
| 5 | COVER | P.E. | BLUE | 1 | UNLESS OTHERWISE SPECIFIED DIMENSIONS ARE IN MILLIMETERS. DIMENSIONS IN [] ARE IN INCHES AND FOR CONSUMER REFERENCE ONLY. | | | |
| 4 | FERRULE | BRASS | NEXCOTE | 1 | UNLESS OTHERWISE SPECIFIED DIMENSIONS ARE IN MILLIMETERS. DIMENSIONS IN [] ARE IN INCHES AND FOR CONSUMER REFERENCE ONLY. | | | |
| 3 | CONTACT PIN | BRASS | SILVER | 1 | UNLESS OTHERWISE SPECIFIED DIMENSIONS ARE IN MILLIMETERS. DIMENSIONS IN [] ARE IN INCHES AND FOR CONSUMER REFERENCE ONLY. | | | |
| 2 | INSULATOR | TEFLON | NATURAL | 1 | UNLESS OTHERWISE SPECIFIED DIMENSIONS ARE IN MILLIMETERS. DIMENSIONS IN [] ARE IN INCHES AND FOR CONSUMER REFERENCE ONLY. | | | |
| 1 | BODY | BRASS | NEXCOTE | 1 | UNLESS OTHERWISE SPECIFIED DIMENSIONS ARE IN MILLIMETERS. DIMENSIONS IN [] ARE IN INCHES AND FOR CONSUMER REFERENCE ONLY. | | | |
| DESCRIPTION | | | | | | | | |
| MATERIAL | | | | | | | | |
| FINISH | | | | | | | | |
| QTY | | | | | | | | |
| DO NOT SCALE DRAWING | | | | | | | | |
| CAD FILE | | | | | | | | |
| C:/272/272141.DWG | | | | | | | | |
| DWG. NO. | | | | | | | | |
| 272141.DWG | | | | | | | | |
| REV. | | | | | | | | |
| A | | | | | | | | |
| SIZE | | | | | | | | |
| A | | | | | | | | |
| SCALE | | | | | | | | |
| NA | | | | | | | | |