

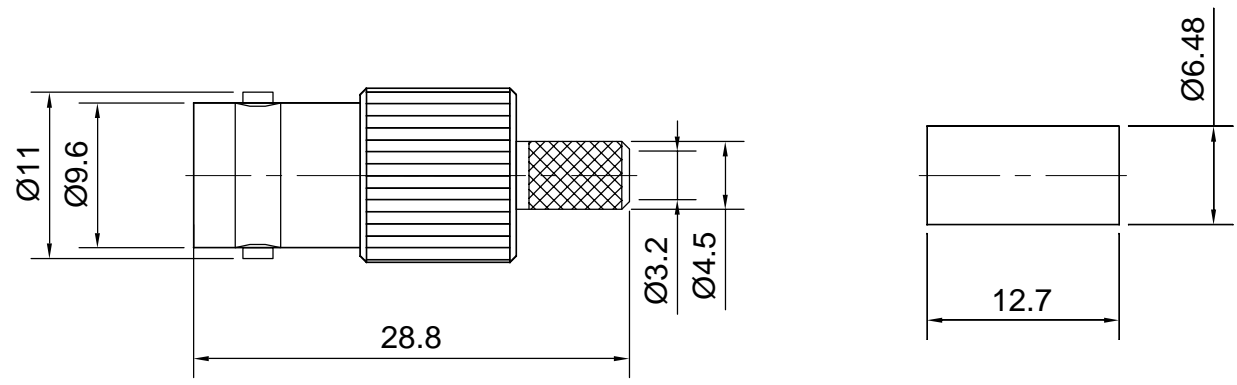

Tolerances 1-20=+/-0.2 20-30=+/-0.3 30-40=+/-0.4 40-50=+/-0.5 50-100=+/-0.75 100-300=+/-1.5 Angles=+/-1 Dimensions are in Millimeters	Revisions Description/Approved/Date	Approved M.H.	Date 06/22/99
		Checked M.H.	Date 06/21/99
		Drawn K.R.E.	Date 06/19/99
NOTES (plating thickness in micro-inches): 1. Per QQ-B-626 2. Per QQ-S-764 3. Per QQ-C-530 4. Per QQ-B-750 5. Per MIL-P-19468 6. Per ZZ-R-765 7. Per WW-T-799 8. Gold pl. 50 min. over nickel pl. 50 min. over copper strike 9. Nickel pl. 100 min. over copper strike 10. Per QQ-P-35 11. Gold pl. 30 min. over nickel pl. 50 min. over copper strike			



ITEM	MATERIAL	FINISH	 Lighthouse Technologies, Inc. 4907 Morena Boulevard, #1411 San Diego, California 92117 Part Number: LTI-BSF11NT-58		
Connector Body	Brass, Note 1	Nickel, Note 9	Description BNC crimp jack for RG-58 Scale 2:1 Drawing No. B/BSF11-58 File Name BSF11-58		
Center Contact: Female	Beryllium Copper, Note 3	Gold, Note 11			
Insulation	Teflon, Note 5	None			
Ferrule	Annealed Copper, Note 7	Same as Body			
Gasket	--	--			
Hex Nut	--	--			
Lock Washer	--	--			